

## MCQ Practice Test 2

### Section I: Multiple-Choice

Time: 80 minutes

40 Questions

**Note:** To simplify calculations, you may use  $g = 10 \text{ m/s}^2$  in all problems.

**Directions:** Each of the questions or incomplete statements below is followed by four suggested answers or completions. Select the one that is best in each case.

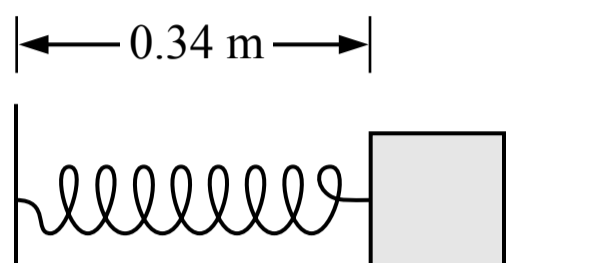

1. A block is attached to a spring which has an original unstretched length of 0.28 m. The other end of the spring is attached to a wall. The block is pulled away from the wall and released, and the block oscillates left and right. Which of the following shows the direction of the spring force acting on the block when it is in the position shown in the figure above?

(A)

(B)

(C)

(D) The magnitude of the spring force is zero

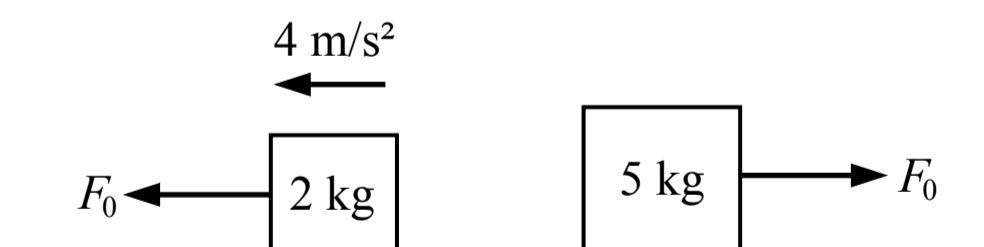

2. Two blocks are on a surface with negligible friction. A force with a magnitude of  $F_0$  is applied to the 2 kg block and it accelerates at  $4 \text{ m/s}^2$ . A force with the same magnitude of  $F_0$  is applied to the 5 kg block. If the block starts at rest, what is the speed of the 5 kg block after 2 seconds?

(A) 1.6 m/s

(B) 3.2 m/s

(C) 4.0 m/s

(D) 8.0 m/s

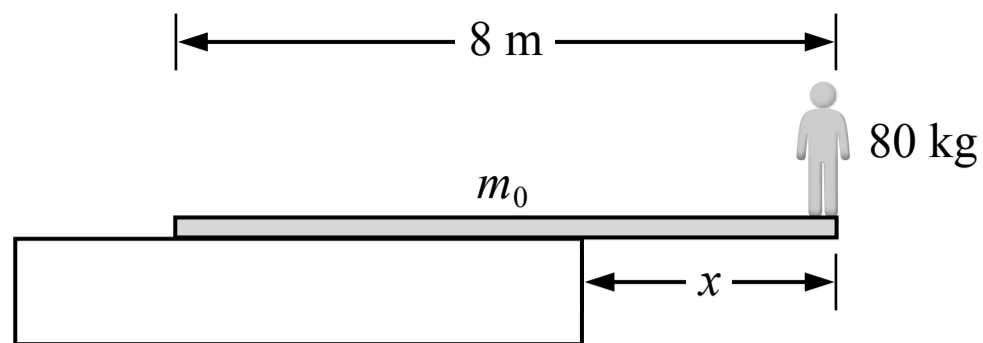

3. An 80 kg person stands at the end of an 8 m long beam with a mass of  $m_0$ . The beam remains at rest on top of a large block as shown in the figure above. What is the maximum distance  $x$  that the beam can extend from the block without the beam rotating?

- (A) 0 m
- (B) 1 m
- (C) 4 m
- (D) Cannot be determined

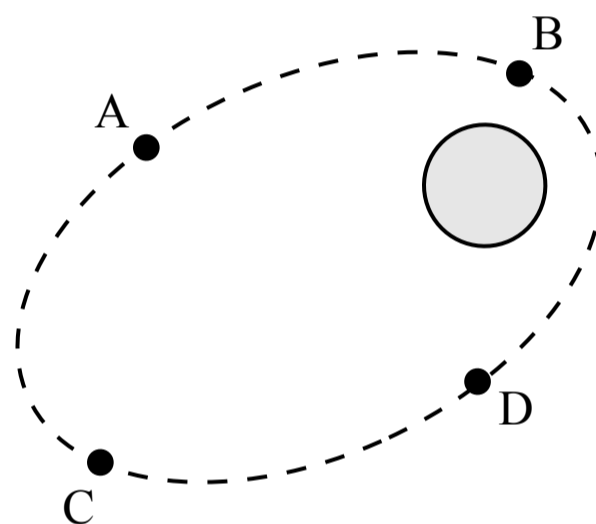

4. A satellite is orbiting a planet as shown in the figure above. At which of the points shown does the satellite have the greatest speed?

- (A) Point A
- (B) Point B
- (C) Point C
- (D) Point D



5. Block A is sliding on a surface with negligible friction when it collides with block B which is initially at rest. After the collision block B moves to the right at 1 m/s. Which of the following could show the momentum of block A before and after the collision?

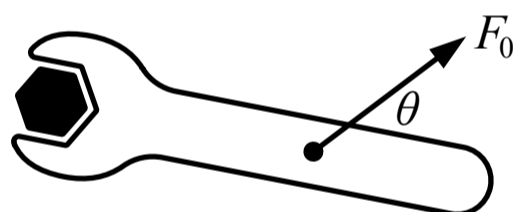
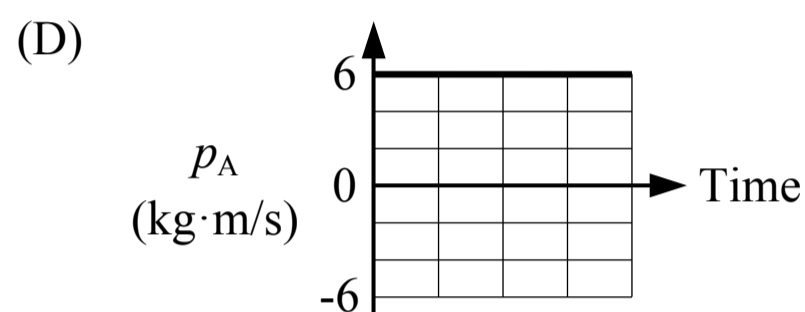
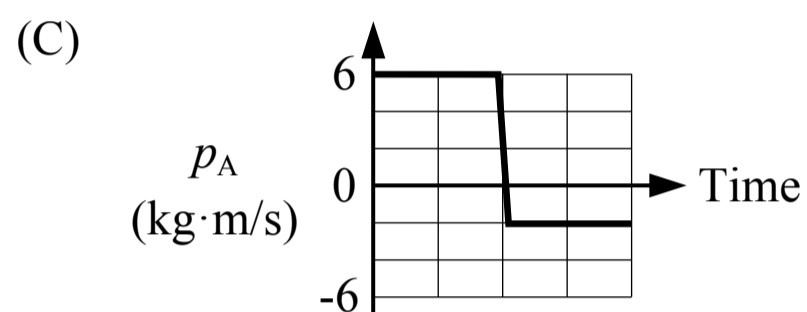
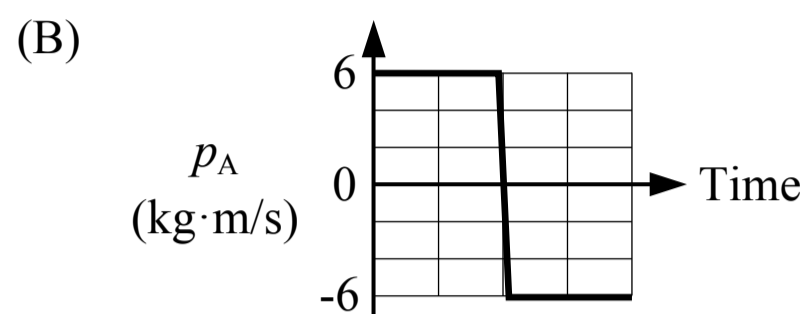
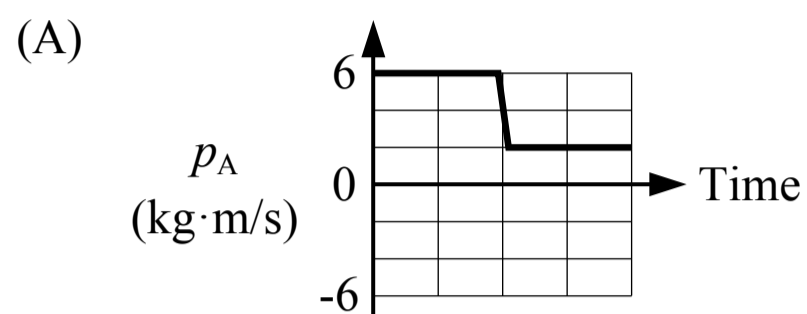

6. A force is exerted on a wrench in order to turn the bolt at the left end of the wrench as shown in the figure above. Which of the following changes would not increase the torque produced by the force about the center of the bolt?
- (A) Increase  $\theta$  to  $90^\circ$
  - (B) Move the force closer to the bolt
  - (C) Double the magnitude of the force
  - (D) All of the above would increase the torque

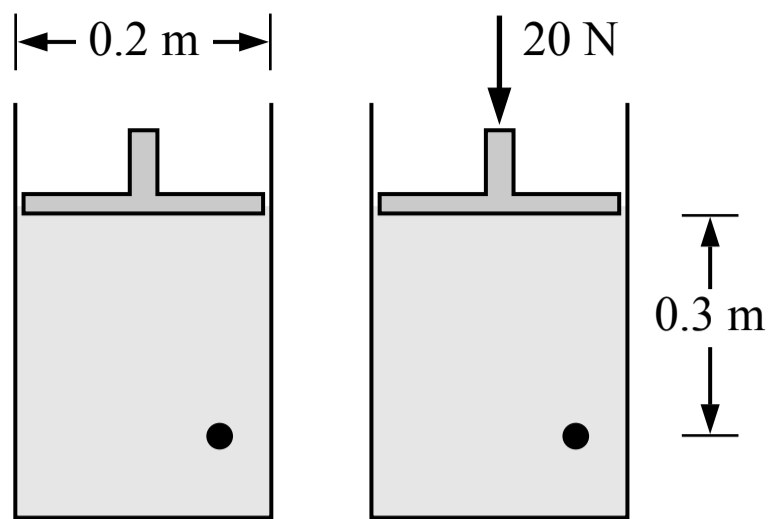

7. A volume of water is contained in a cylinder below a piston as shown in the figure above. The diameter of the circular piston is 0.2 m. A force of 20 N is then applied to the piston. What is the change in pressure at the point shown, 0.3 m below the piston, when the 20 N force is applied? The density of the water is  $1,000 \text{ kg/m}^3$ .
- (A) 159 Pa  
 (B) 3,000 Pa  
 (C) 637 Pa  
 (D) 3,637 Pa

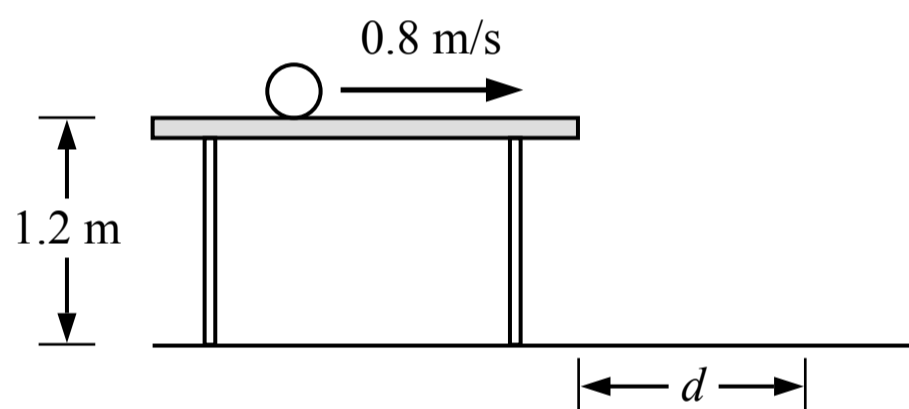

Note: Figure not drawn to scale.

8. A ball is rolling on a table with a constant speed as shown in the figure above. The ball rolls off the table and lands on the ground. What distance  $d$  from the edge of the table does the ball first hit the ground?
- (A) 0.4 m  
 (B) 0.5 m  
 (C) 0.8 m  
 (D) 1.2 m

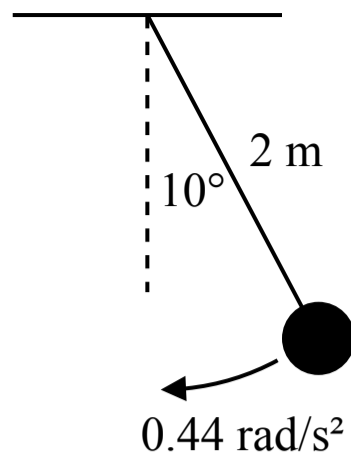

Note: Figure not drawn to scale

9. A pendulum consisting of a mass hanging from a 2 m long string is shown in the figure above. When the mass swings all the way to the right it momentarily comes to rest and the string forms a  $10^\circ$  angle with the vertical. If the pendulum experiences a constant angular acceleration of  $0.44 \text{ rad/s}^2$  as it swings down, the speed of the mass when it reaches the lowest point (and the string is vertical) is most nearly

- (A) 0.8 m/s
- (B) 5.9 m/s
- (C) 0.4 m/s
- (D) 0.2 m/s

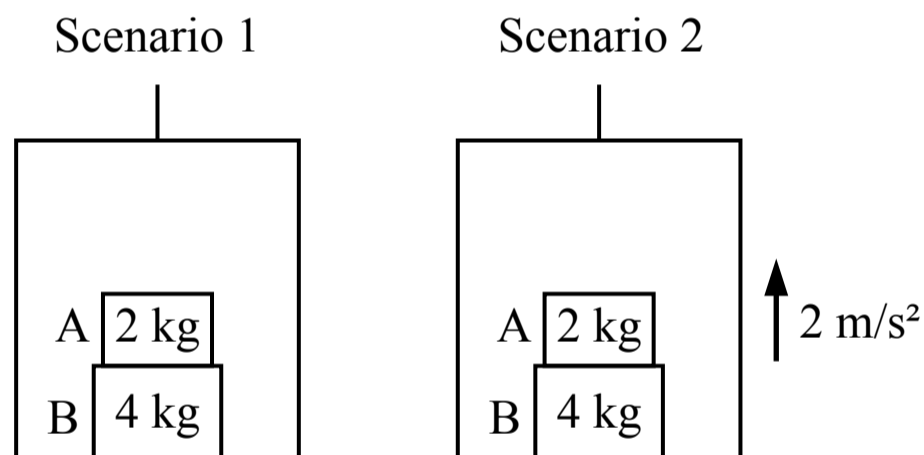

10. Two blocks with different masses are stacked on the floor of an elevator as shown in the figure above. In scenario 1 the elevator is at rest and in scenario 2 the elevator is accelerating upwards. Which of the following statements is true?

- (A) The weight of block A in scenario 1 is greater than the weight of block B in scenario 2
- (B) The weight of block B in scenario 1 is greater than the weight of block A in scenario 2
- (C) The weight of block B in scenario 1 is equal to the weight of block A in scenario 2
- (D) The weight of block A in scenario 1 is equal to the weight of block B in scenario 1

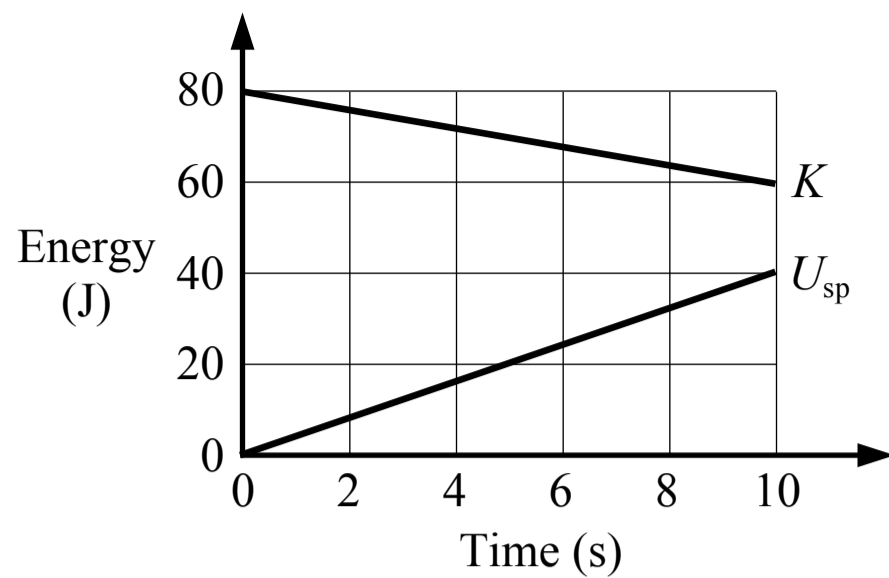

11. A graph of the energy in a system, which only has kinetic energy and spring potential energy, is shown in the figure above. Which of the following is true about this system?

- (A) There are no external forces acting on the system
- (B) There must be at least one external force acting on the system
- (C) There must be a friction force acting on the system
- (D) It cannot be determined if there are any external forces acting on the system

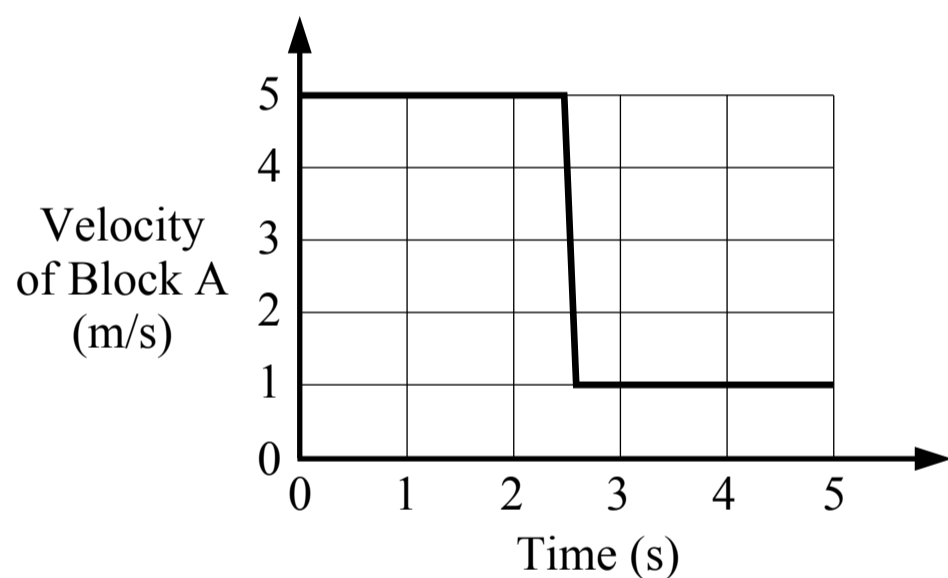

12. Block A is sliding on a surface with negligible friction towards block B which is initially at rest. The blocks collide and the collision is perfectly elastic. A graph of the velocity of block A is shown in the figure above. What is the speed of block B after the collision?

- (A) 6 m/s
- (B) 5 m/s
- (C) 4 m/s
- (D) 1 m/s

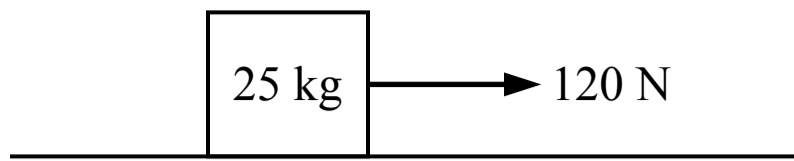

13. A block is sitting at rest on a floor when a 120 N force is exerted on the block. The coefficients of static friction and kinetic friction between the block and the floor are  $\mu_s = 0.6$  and  $\mu_k = 0.4$ . Which of the following graphs shows the kinetic energy of the block after the 120 N force is applied?

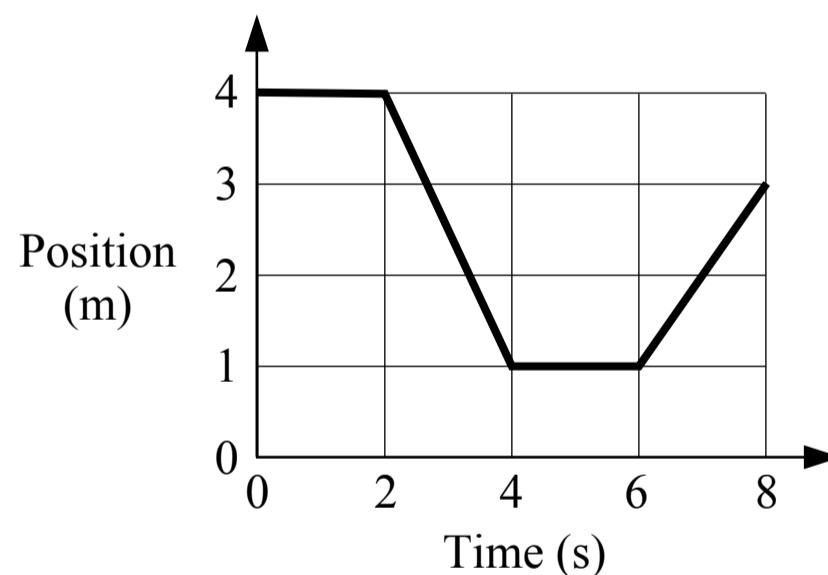
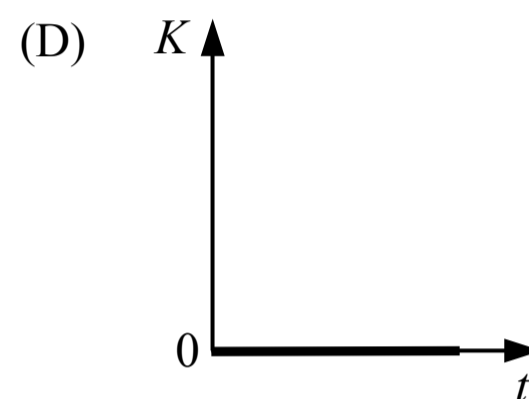
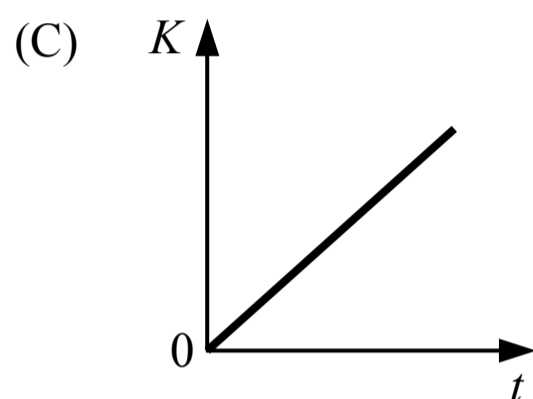
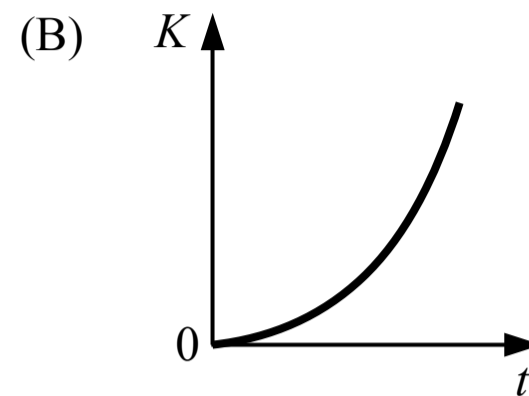
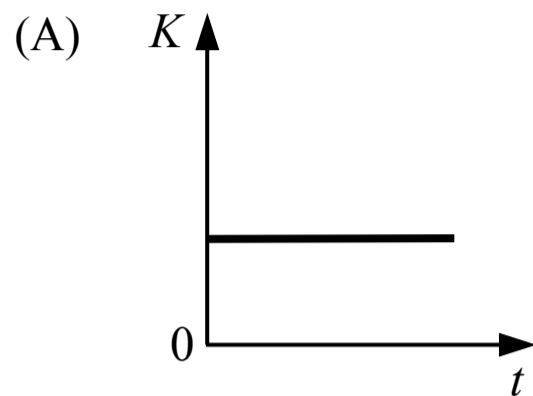

14. A cart moves on a horizontal track and its motion is shown in the graph above. Which of the following statements is true about the momentum of the cart?
- (A) The magnitude of the momentum is decreasing from 2 seconds to 4 seconds
  - (B) The magnitude of the momentum from 0 seconds to 2 seconds is greater than it is from 4 seconds to 6 seconds
  - (C) The magnitude of the momentum from 2 seconds to 4 seconds is greater than it is from 6 seconds to 8 seconds
  - (D) The magnitude of the momentum is changing from 6 seconds to 8 seconds

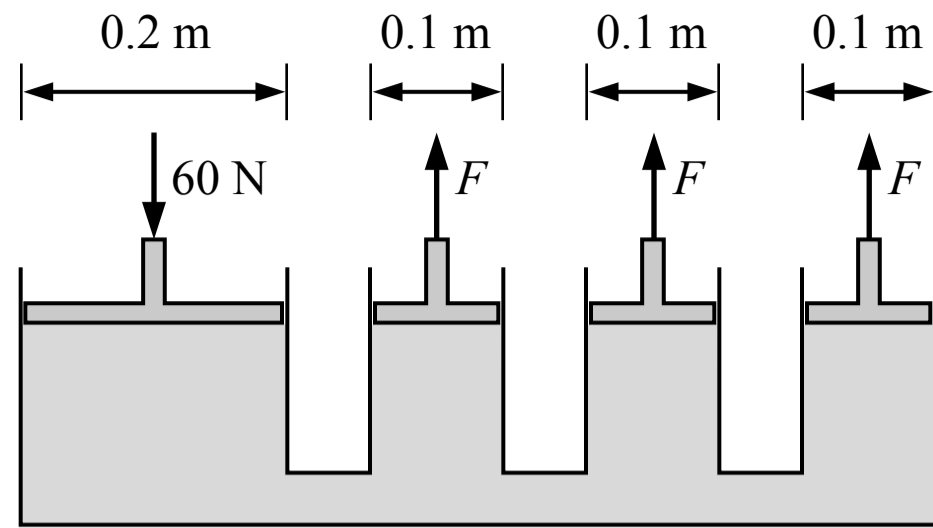

Note: Figure not drawn to scale.

15. A series of square tubes are connected and filled with liquid as shown in the figure above. The area of each piston is a square and the side lengths of the pistons are shown. When a 60 N force is applied to the left piston, what is the magnitude of the force exerted on each of the three right pistons,  $F$ ?
- (A) 30 N  
 (B) 20 N  
 (C) 60 N  
 (D) 15 N



16. Two blocks are separated by a compressed spring with negligible mass and are held at rest on a frictionless surface. The blocks are released at time  $t_1$ . The spring expands and the 2 kg block loses contact with the spring at time  $t_2$  and the spring remains attached to the 10 kg block. Which of the following shows the acceleration of the center of mass of the system of the two blocks and the spring?

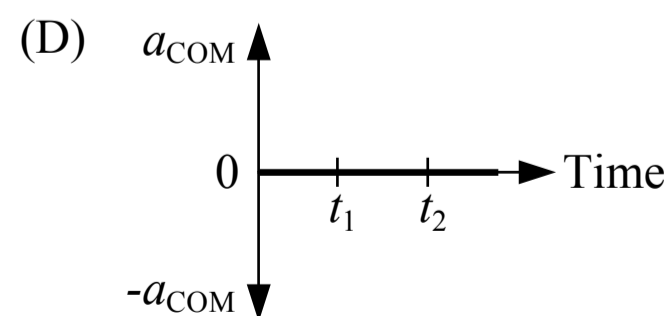
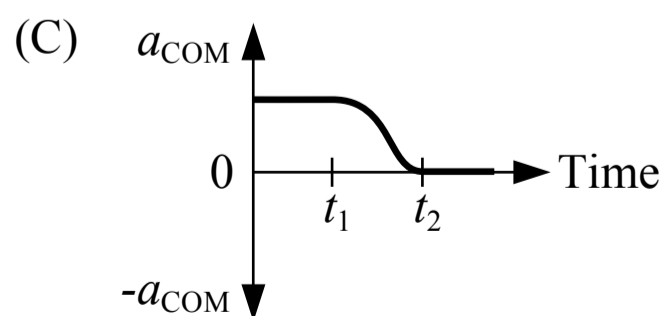
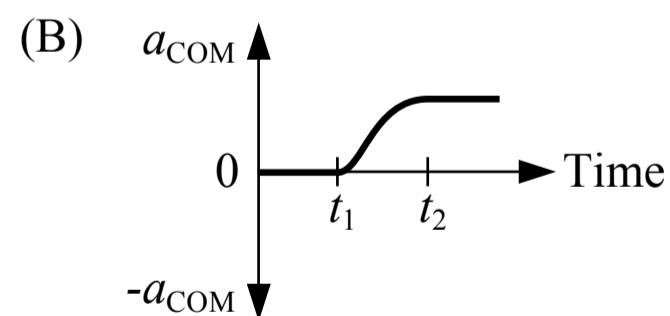
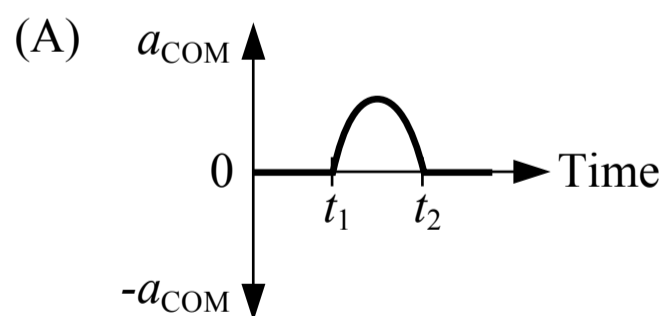

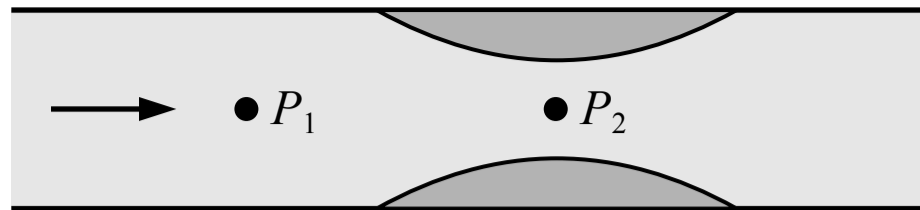

17. Water is flowing through a pipe as shown in the figure above. Some material has collected inside the pipe which has created a narrower opening for the fluid to flow through. How do the pressures at the two points shown compare?

- (A)  $P_1 = P_2$
- (B)  $P_1 > P_2$
- (C)  $P_1 < P_2$
- (D) Cannot be determined

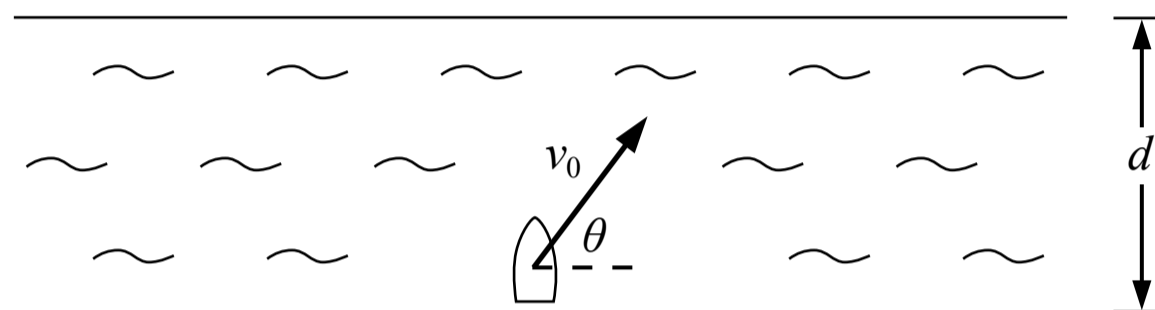

18. A boat crosses a river with a width of  $d$ . The boat points straight across the river and the river is flowing to the right. The resultant velocity of the boat is a constant  $v_0$  as shown in the figure above. When the boat reaches the other side of the river, the distance that the boat moves downstream (to the right) is

- (A)  $\frac{d \sin(\theta)}{\cos(\theta)}$
- (B)  $\frac{d}{v_0 \sin(\theta)}$
- (C)  $\frac{d \cos(\theta)}{\sin(\theta)}$
- (D)  $\frac{d}{v_0 \cos(\theta)}$

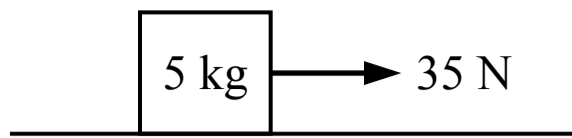

19. A block with a mass of 5 kg is sitting at rest. The coefficient of static friction between the block and the floor is 0.5 and the coefficient of kinetic friction is 0.4. A force with a magnitude of 35 N is then applied to the block. After the force is applied, the acceleration of the block is most nearly

- (A) 0 m/s<sup>2</sup>
- (B) 3 m/s<sup>2</sup>
- (C) 7 m/s<sup>2</sup>
- (D) 2 m/s<sup>2</sup>

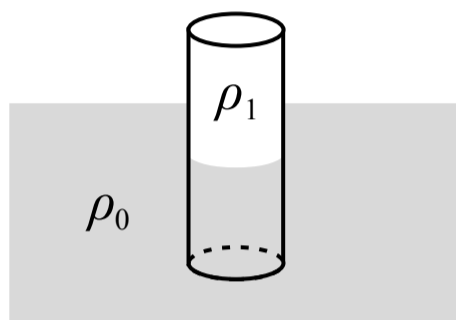

Note: Figure not drawn to scale.

20. A solid cylinder is floating partially submerged in a liquid as shown in the figure above. The density of the liquid  $\rho_0$  is 1,100 kg/m<sup>3</sup> and the density of the cylinder  $\rho_1$  is 900 kg/m<sup>3</sup>. The percent of the cylinder's volume that is below the surface of the liquid is most nearly

- (A) 22%
- (B) 82%
- (C) 18%
- (D) 90%

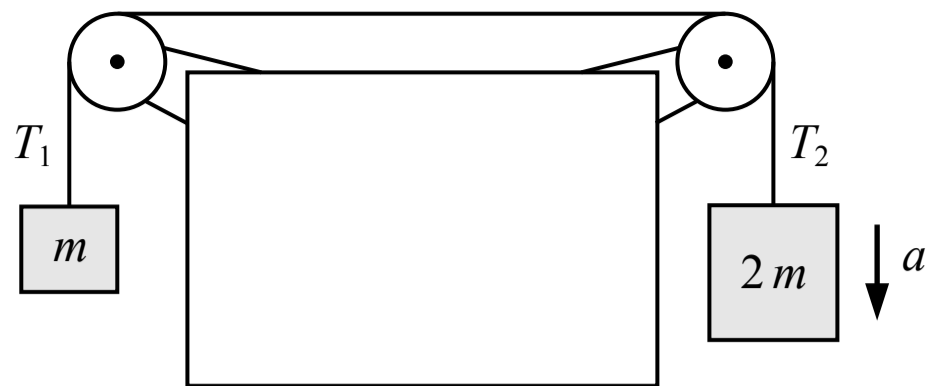

21. Two blocks are connected by a string with negligible mass which passes over two pulleys with negligible mass and negligible friction as shown in the figure above. One block has twice the mass of the other block and accelerates downwards. Which of the following correctly relates the tensions in the two segments of the string?

- (A)  $T_1 < T_2$
- (B)  $T_1 > T_2$
- (C)  $T_1 = T_2$
- (D) A comparison between the tensions cannot be determined

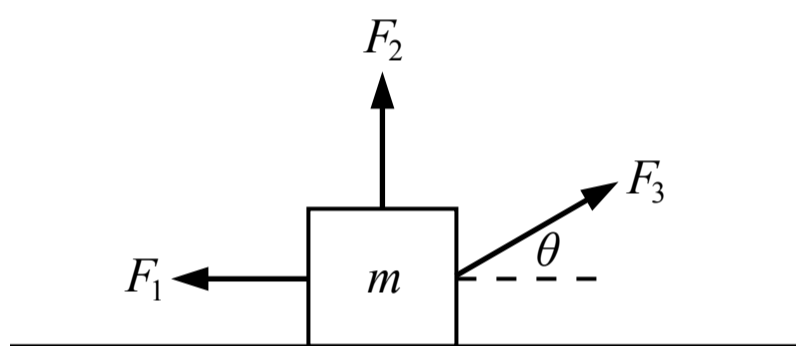

22. Three forces are exerted on a block of mass  $m$  which is sitting on a surface with negligible friction. The block accelerates but remains in contact with the surface. Which of the following is a correct expression for the acceleration of the block?

- (A)  $\frac{F_2 + F_3 \sin(\theta) - F_1}{m}$
- (B)  $\frac{F_3 \cos(\theta) + F_1}{m}$
- (C)  $\frac{F_2 + F_3 \sin(\theta)}{m}$
- (D)  $\frac{F_3 \cos(\theta) - F_1}{m}$

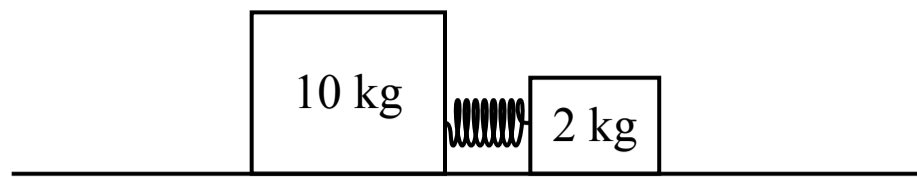

23. Two blocks are connected by a spring and are placed on a surface where the friction between the surface and the blocks is negligible. The blocks are held in place so that the spring is initially compressed. When the blocks are released, which block experiences an impulse with a greater magnitude?

- (A) The 10 kg block
- (B) The 2 kg block
- (C) The blocks experience an impulse with the same magnitude
- (D) Cannot be determined

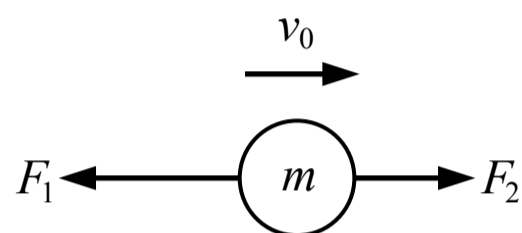

24. An object of mass  $m$  is moving with an initial speed  $v_0$  when two forces are applied as shown in the figure above. If  $F_1 > F_2$  in magnitude, which of the following graphs show the speed of the object over time?

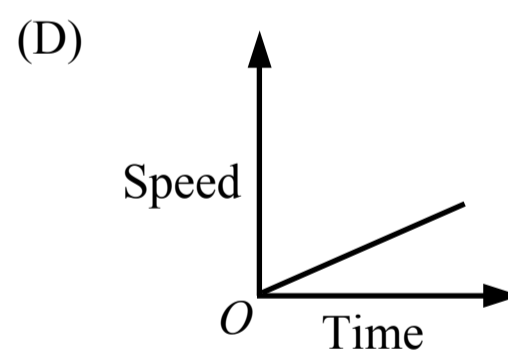
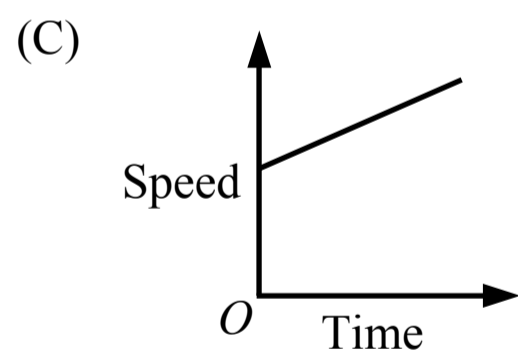
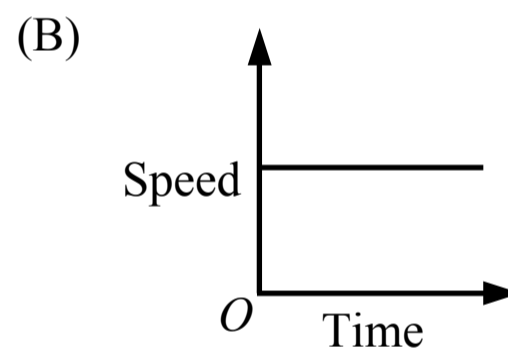
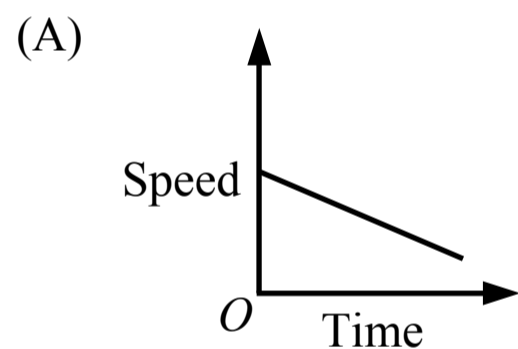

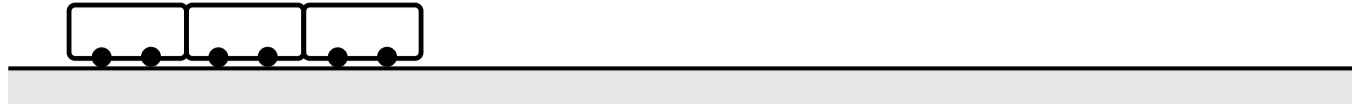

25. A train is stopped at a station. From time  $t_0$  to time  $t_1$  the train accelerates and then after time  $t_1$  the train moves at a constant speed. Which of the following graphs could represent the motion of the train?

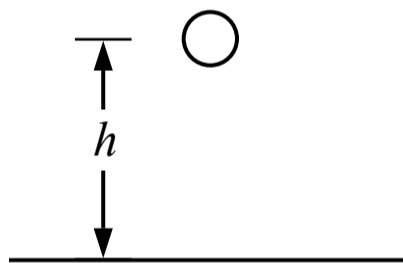
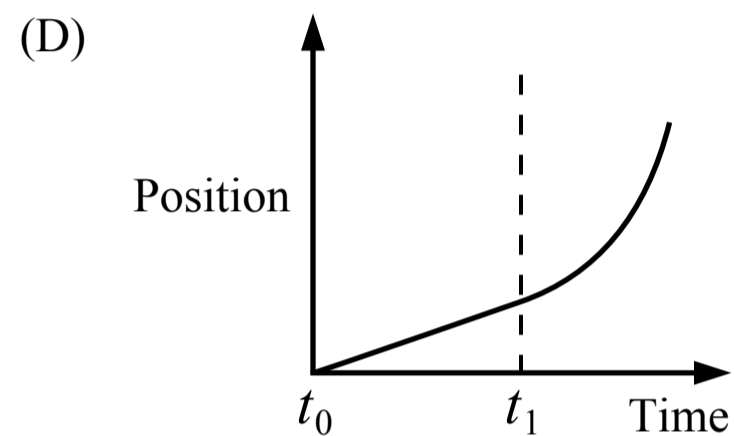
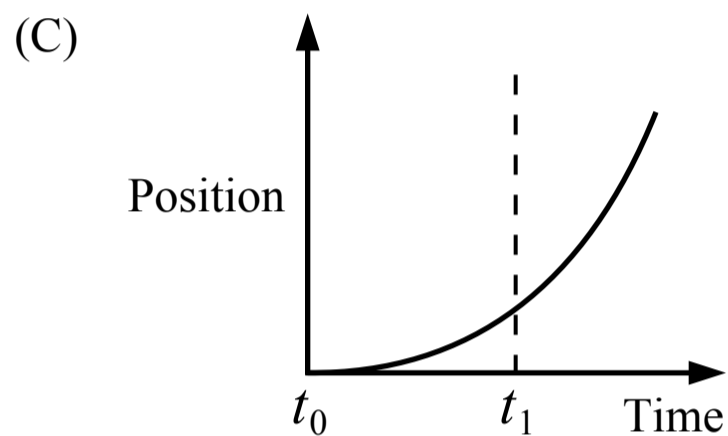
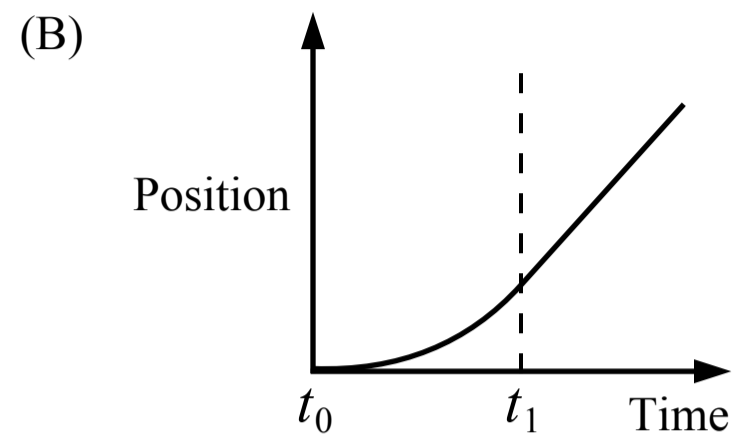
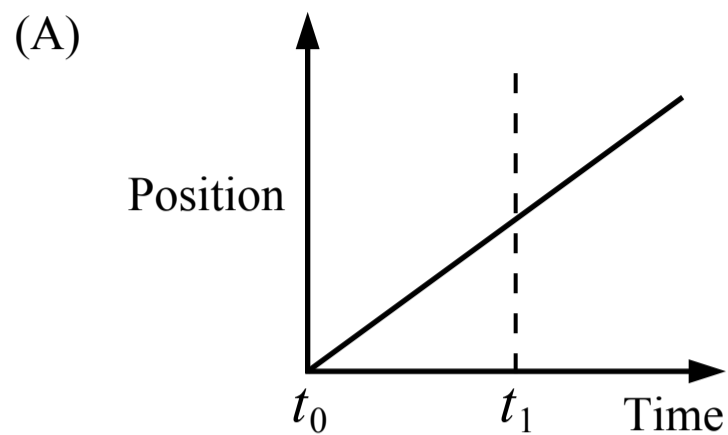

26. A ball with a mass of  $m$  is at a height of  $h$  above the ground on a planet with a mass of  $M$  and a radius of  $R$ . Which of the following is a correct expression for the acceleration of the ball the moment it is released from that height?

(A)  $\frac{GM}{R^2}$

(B)  $\frac{GMm}{(R+h)^2}$

(C)  $\frac{GM}{(R+h)^2}$

(D)  $\frac{GMm}{R^2}$

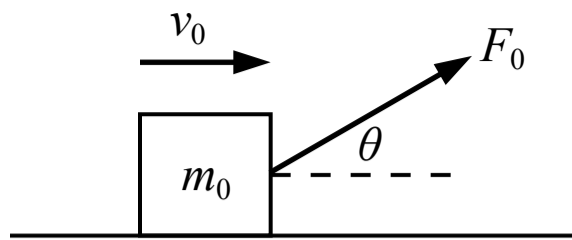

27. A block is sliding on a surface with negligible friction with a speed of  $v_0$  when a force is applied to the block as shown in the figure above. When the block has moved a distance of  $d_0$  it has kinetic energy  $K_0$ . If the motion was repeated with a greater value of  $\theta$  and no other changes, the kinetic energy of the block after moving a distance of  $d_0$  would be
- (A) less than  $K_0$
  - (B) greater than  $K_0$
  - (C) equal to  $K_0$
  - (D) Cannot be determined

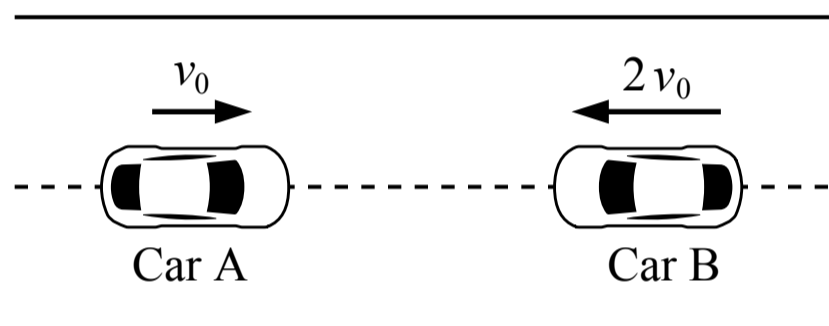

28. During a crash test, cars A and B are driven into each other head on as show in the figure above. Car A is moving at a speed of  $v_0$  and car B is moving at a speed of  $2v_0$ . Which of the following is true during the crash?
- (A) The force exerted by car A on car B has twice the magnitude as the force exerted by car B on car A
  - (B) The force exerted by car B on car A has twice the magnitude as the force exerted by car A on car B
  - (C) The force exerted by car A on car B has the same magnitude as the force exerted by car B on car A
  - (D) The relationship of the forces between car A and car B cannot be determined without knowing the masses

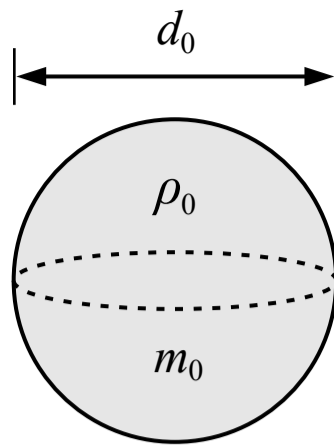

29. A solid sphere with a diameter of  $d_0$ , a mass of  $m_0$  and a density of  $\rho_0$  is shown in the figure above. A second sphere with the same density and twice the diameter would have a mass of

- (A)  $4 m_0$
- (B)  $16 m_0$
- (C)  $2 m_0$
- (D)  $8 m_0$

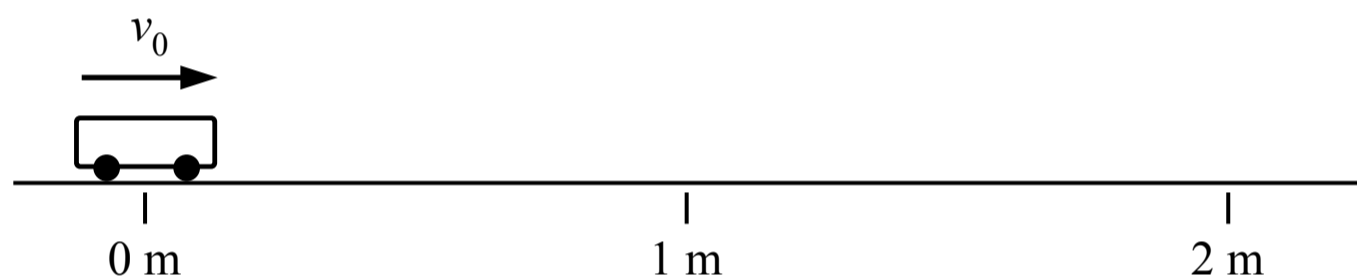

30. A car is placed on a track as shown in the figure above and given an initial velocity. The car passes the  $1 \text{ m}$  mark with a speed of  $2 \text{ m/s}$  and it passes the  $2 \text{ m}$  mark with a speed of  $1 \text{ m/s}$ . The acceleration of the car is most nearly

- (A)  $0.75 \text{ m/s}^2$
- (B)  $-0.75 \text{ m/s}^2$
- (C)  $1.5 \text{ m/s}^2$
- (D)  $-1.5 \text{ m/s}^2$

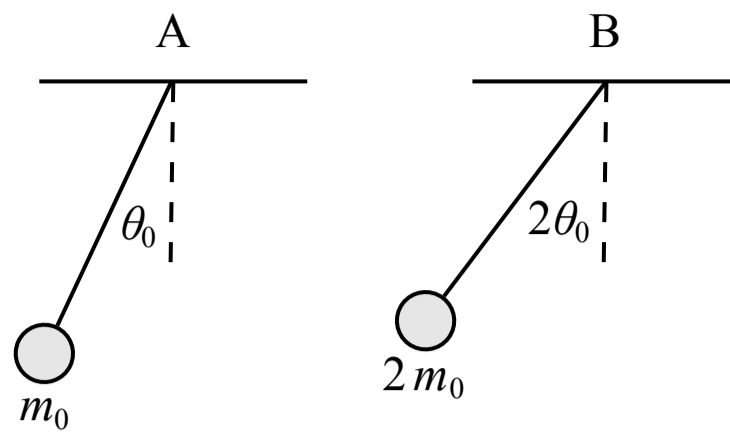

Note: Figure not drawn to scale.

31. Two spheres are attached to identical strings and released from rest at the angles shown in the figure above. Which of the following correctly relates the periods of pendulum A and pendulum B?

- (A)  $T_B = 4 T_A$
- (B)  $T_B = 2 T_A$
- (C)  $T_B = T_A$
- (D)  $T_B = T_A/2$

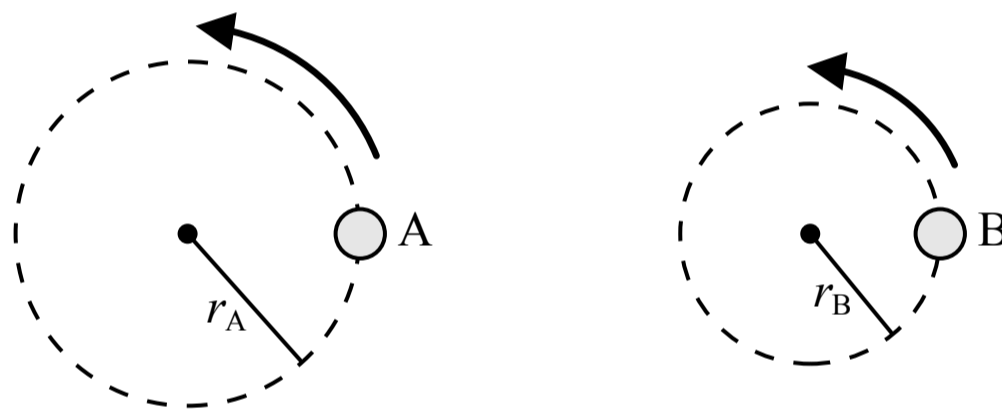

32. Two objects are in uniform circular motion. Object A follows a circular path with radius  $r_A$  and object B follows a circular path with a radius of  $r_B < r_A$ . If the period of each object's circular motion is the same, the magnitude of the acceleration of object B is

- (A) less than the magnitude of the acceleration of object A
- (B) greater than the magnitude of the acceleration of object A
- (C) equal to the magnitude of the acceleration of object A
- (D) a comparison between the acceleration of object A and object B cannot be determined

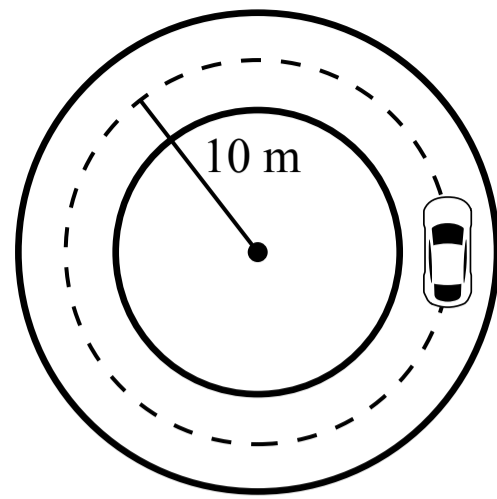

Top view

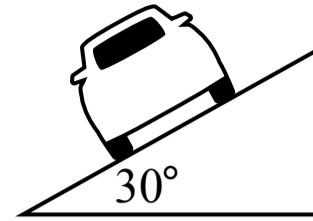

Side view

33. A car is driving around a banked circular track at a constant speed as shown in the figure above. The track is inclined at an angle of  $30^\circ$  with the ground and the radius of the circular path of the car is 10 m. The track is covered in ice and the friction between the tires and the inclined track is negligible, but the car does not slide up or down the incline. The speed of the car is most nearly

- (A) 10.0 m/s
- (B) 13.2 m/s
- (C) 7.6 m/s
- (D) 7.1 m/s

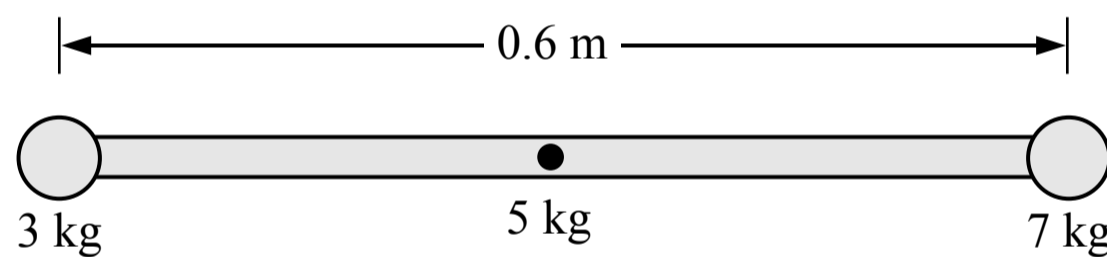

34. A 3 kg sphere and a 7 kg sphere are attached to the ends of a 5 kg rod which is free to rotate about an axle passing through its center. When the rod is horizontal as shown in the figure above, the magnitude of the net torque on the rod about the axle is most nearly

- (A) 60 N·m
- (B) 12 N·m
- (C) 30 N·m
- (D) 90 N·m

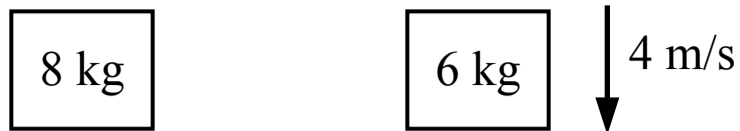

35. An 8 kg block is dropped from rest at the same time that a 6 kg block is falling at a speed of 4 m/s. Which of the two blocks has a greater momentum 2 seconds later (assuming the blocks are still falling)?
- (A) The 6 kg block  
 (B) The 8 kg block  
 (C) The blocks will have the same momentum  
 (D) Cannot be determined

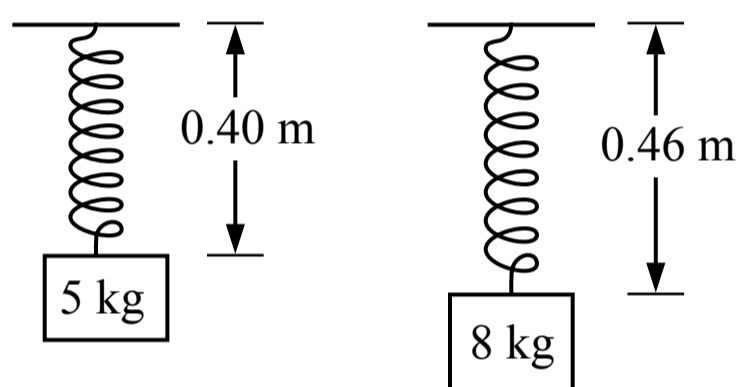

36. A 5 kg block is suspended from a spring attached to the ceiling. When the block is at rest the spring is 0.40 m long. The 5 kg block is removed and replaced with an 8 kg block. When the new block is at rest the spring is 0.46 m long. The spring constant of the spring is most nearly
- (A) 125 N/m  
 (B) 1333 N/m  
 (C) 174 N/m  
 (D) 500 N/m

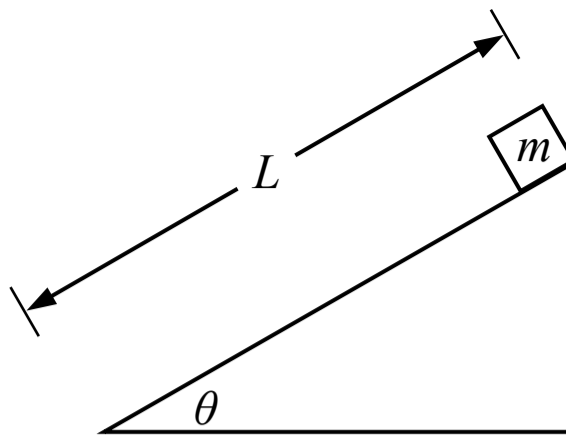

37. A small block of mass  $m$  starts at rest at the top of an incline with a length of  $L$ . The block slides down the incline and the coefficient of kinetic friction between the block and the incline is  $\mu_k$ . Which of the following is a correct expression for the speed of the block at the bottom of the incline?

- (A)  $\sqrt{2gL \sin(\theta) - 2gL\mu_k \cos(\theta)}$
- (B)  $mgL \sin(\theta) - mgL\mu_k \cos(\theta)$
- (C)  $\sqrt{2gL \sin(\theta)}$
- (D)  $mgL \sin(\theta)$

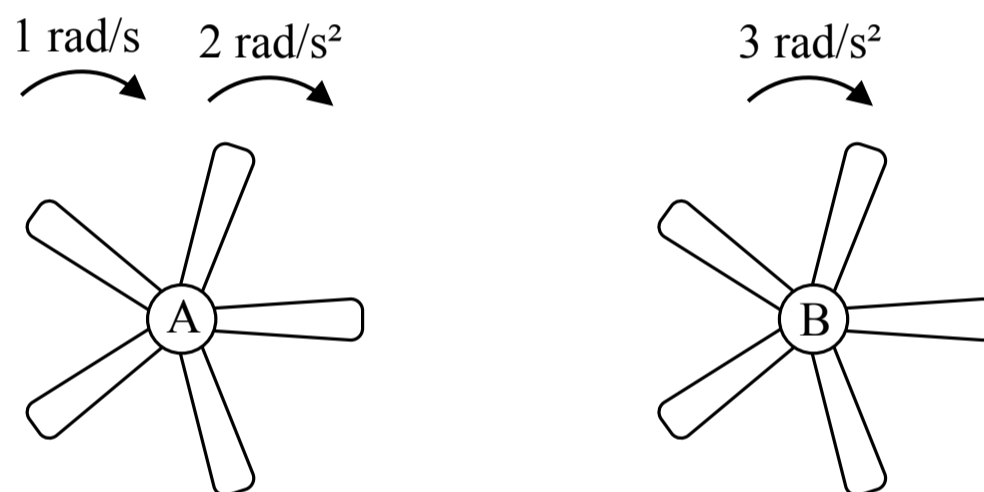

38. Two ceiling fans are shown in the figure above. At time  $t_0$ , fan A is spinning at  $1 \text{ rad/s}$  and begins accelerating at  $2 \text{ rad/s}^2$ , while fan B starts from rest and accelerates at  $3 \text{ rad/s}^2$ . What is the relationship between the angular speed of the fans after a period of 5 seconds?

- (A)  $\omega_A < \omega_B$
- (B)  $\omega_A > \omega_B$
- (C)  $\omega_A = \omega_B$
- (D) Cannot be determined

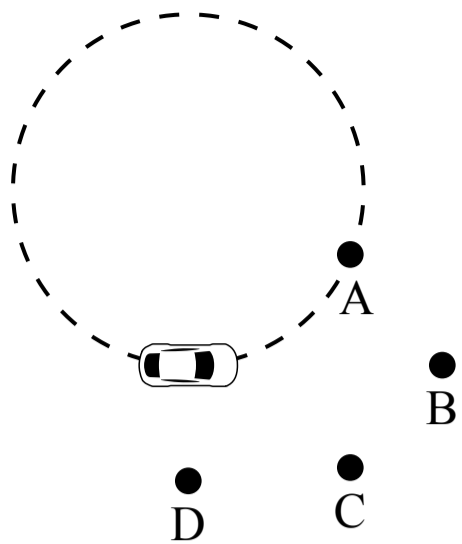

39. A car is driving around in a counterclockwise circle at a constant speed as shown in the figure above. The car is driving on ice but the friction between the tires and the ice is great enough for the car to drive in the circle. When the car is in the position shown the tires slip. If the friction force on the tires is assumed to be zero after that moment, which of the points shows the position of the car a period of time later?

- (A) Point A
- (B) Point B
- (C) Point C
- (D) Point D

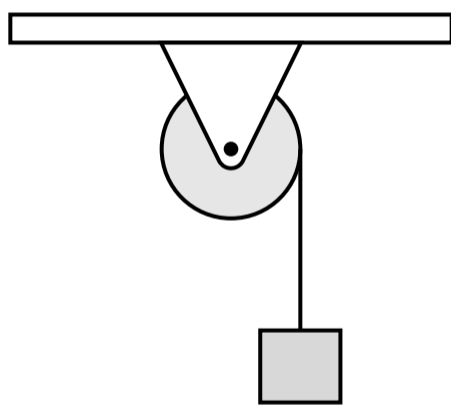

40. A block is hanging from a string which is wrapped around the outside of a pulley as shown in the figure above. The mass of the pulley and the block is not negligible, but the friction on the pulley's axle is negligible. The pulley and block are released from rest. Which of the following graphs shows the motion of the pulley?

