

MCQ Practice Test 4

Section I: Multiple-Choice

Time: 80 minutes

40 Questions

Note: To simplify calculations, you may use $g = 10 \text{ m/s}^2$ in all problems.

Directions: Each of the questions or incomplete statements below is followed by four suggested answers or completions. Select the one that is best in each case.

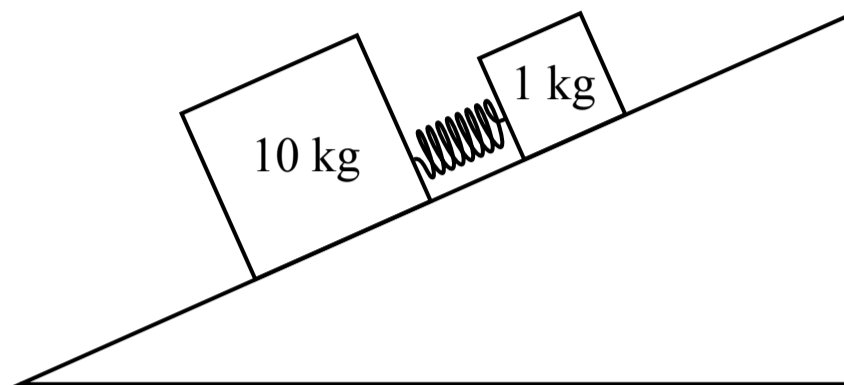

1. Two blocks are connected by a spring and placed on an incline with negligible friction. The blocks are held so that the spring is initially compressed. The blocks are then released from rest and they move apart from each other due to the spring. After the blocks are released, the location of the center of mass of the blocks-spring system
- (A) will move up the incline
 - (B) will move down the incline
 - (C) will not move
 - (D) the motion of the center of mass cannot be determined

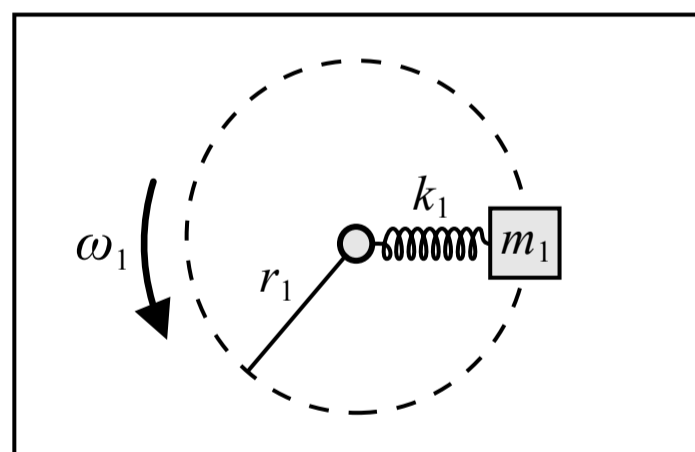

Top view

Figure 1

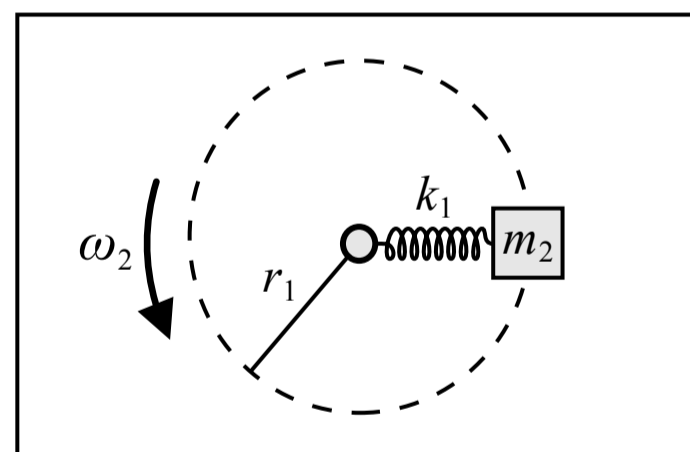

Top view

Figure 2

2. In Figure 1 above a small block of mass m_1 is attached to one end of a spring with a spring constant of k_1 and the other end of the spring is attached to an axle which passes through a hole in the table. A motor below the table causes the axle to rotate with a constant angular speed of ω_1 and the block travels in a horizontal circle with a radius of r_1 on the surface of the table which has negligible friction. In Figure 2 the block is replaced with a different block that has the same dimensions but a mass of m_2 where $m_2 > m_1$. The motor now rotates the axle with a constant angular speed of ω_2 so that the radius of the circular path is still r_1 . How does ω_2 compare to ω_1 ?
- (A) $\omega_1 < \omega_2$
 - (B) $\omega_1 = \omega_2$
 - (C) $\omega_1 > \omega_2$
 - (D) Cannot be determined

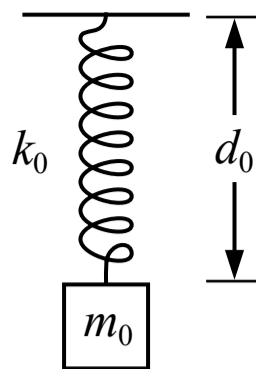

3. A block of mass m_0 is suspended from the ceiling by a spring with a spring constant of k_0 . The block is pulled down to a distance of d_0 from the ceiling and released from rest, and the block oscillates up and down. Which of the following changes would increase the frequency of the oscillation?
- (A) Replace the block with a different block of mass $m_0/2$
 - (B) Pull the block down to a distance of $2d_0$
 - (C) Replace the spring with a different spring with a spring constant of $k_0/2$ and the same original length
 - (D) Pull the block down to a distance of $d_0/2$

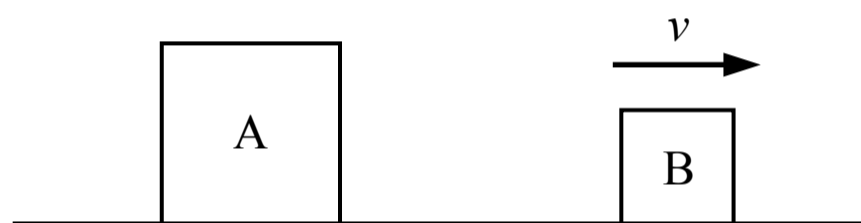

4. Block A is sitting on the ground at rest and block B is moving with a constant velocity as shown in the figure above. The mass of block A is greater than the mass of block B. Which of the following is true of the net force acting on block A and the net force acting on block B?
- (A) The net force on block A is greater than the net force on block B
 - (B) The net force on block B is greater than the net force on block A
 - (C) The net force on block A is equal to the net force on block B
 - (D) The relationship between the net force on block A and block B cannot be determined

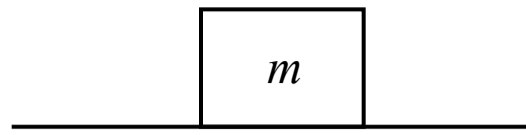

5. A block with a mass of m is sitting on the surface of a planet where the gravitational field strength is 20% of the gravitational field strength near the surface of earth. If the weight of the block on this planet is 100 N the mass of the block is most nearly

- (A) 10 kg
- (B) 50 kg
- (C) 2 kg
- (D) 13 kg

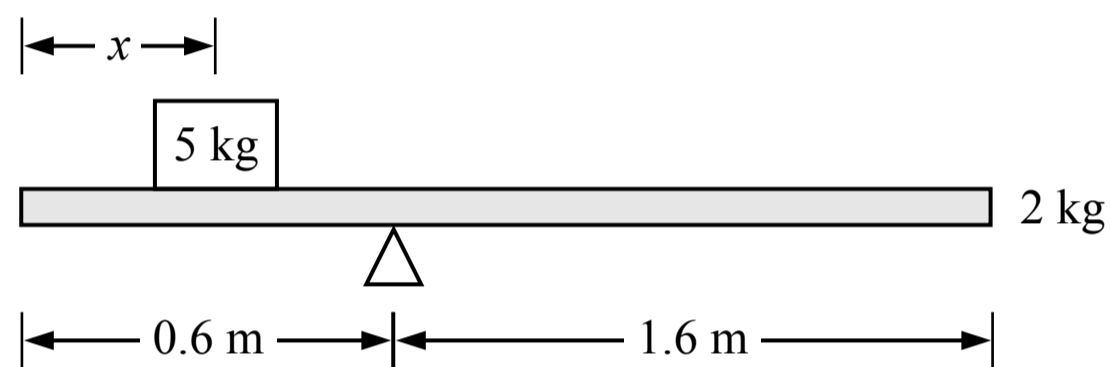

Note: Figure not drawn to scale.

6. A 2 kg beam is resting on a pivot point and a 5 kg block is resting on the beam as shown in the figure above. If the beam and the block remain at rest, what is the distance between the center of the block and the left end of the beam?

- (A) 0.8 m
- (B) 0.2 m
- (C) 0.6 m
- (D) 0.4 m

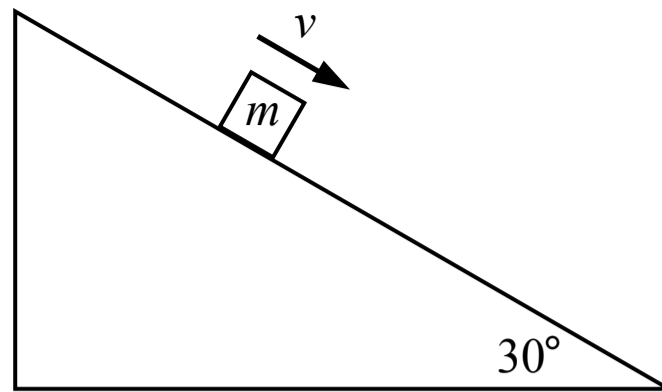

7. A block slides down an incline with a constant speed as shown in the figure above. The friction between the incline and the block is not negligible. Which of the following statements is true about the work done on the block?
- (A) The magnitude of the work done by gravity is equal to the magnitude of the work done by friction
 - (B) The magnitude of the work done by friction is equal to the magnitude of the work done by the normal force
 - (C) The magnitude of the work done by gravity is greater than the magnitude of the work done by friction
 - (D) The magnitude of the work done by gravity is equal to the magnitude of the work done by the normal force

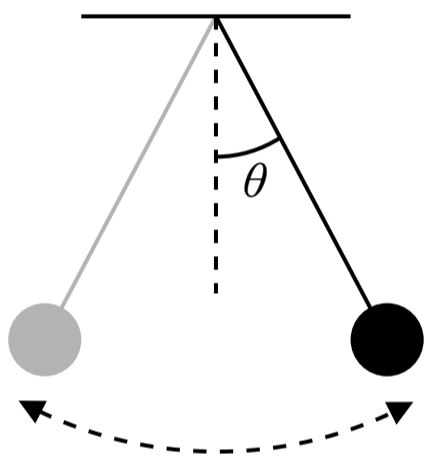

Note: Figure not drawn to scale

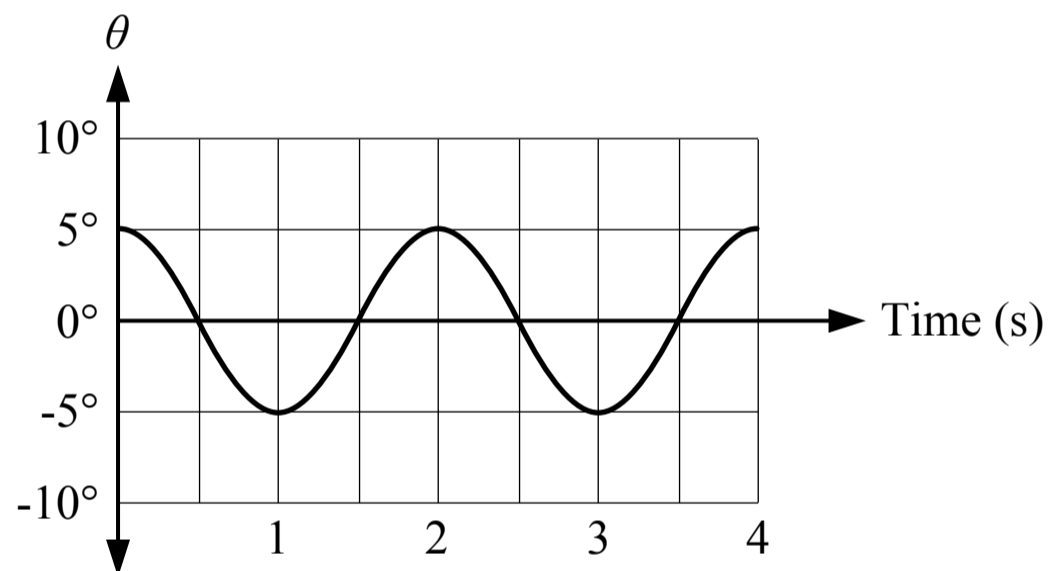

8. A graph of the motion of a pendulum is shown in the figure above. The angle of the pendulum is measured relative to the vertical. Which of the following is true about the motion of the pendulum?
- (A) The angular velocity of the pendulum at 1.5 seconds is zero
 - (B) The angular velocity of the pendulum at 3 seconds is zero
 - (C) The angular velocity of the pendulum is never zero
 - (D) The angular velocity of the pendulum is always zero

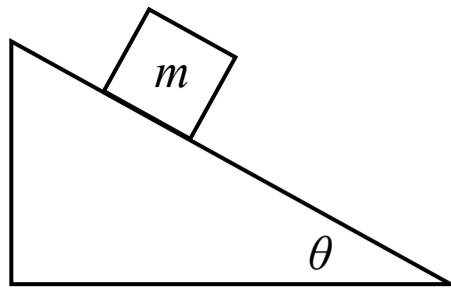

9. A block with a mass of m is sitting at rest on an incline as shown in the figure above. The coefficient of static friction between the block and the incline surface is μ_s . Which of the following must be equal to the magnitude of the friction force acting on the block?

- (A) $\mu_s m g \cos(\theta)$
- (B) $\mu_s m g \sin(\theta)$
- (C) $m g \sin(\theta)$
- (D) $\mu_s m g$

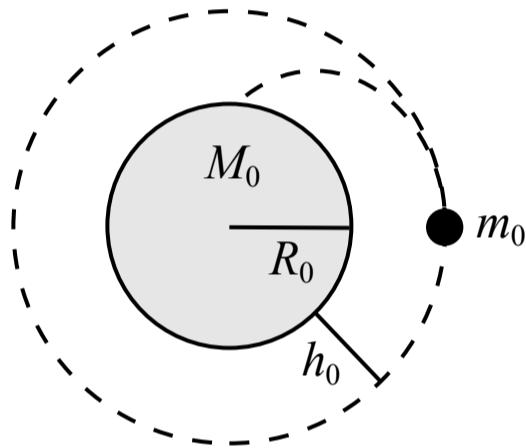

10. A space capsule with a mass m_0 of 500 kg is launched into a circular orbit at a height h_0 of 400 km above the surface of a planet which has a mass M_0 of 1×10^{24} kg and a radius of 1×10^6 m. What is the speed of the capsule in orbit?

- (A) 8.2×10^6 m/s
- (B) 12.9×10^3 m/s
- (C) 8.2×10^3 m/s
- (D) 6.9×10^3 m/s

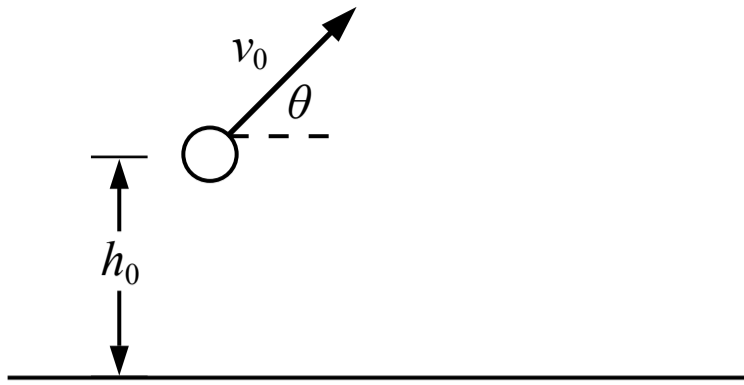

11. A ball at a height h_0 above the ground is given initial velocity v_0 as shown in the figure above. The magnitude of the velocity at the moment before the ball lands on the ground is

- (A) $\sqrt{(v_0 \cos\theta)^2 + (v_0 \sin\theta)^2}$
- (B) $\sqrt{(v_0 \cos\theta)^2 + (v_0 \sin\theta)^2 - 2gh_0}$
- (C) $v_0 \sin\theta$
- (D) $\sqrt{(v_0 \cos\theta)^2 + (v_0 \sin\theta)^2 + 2gh_0}$

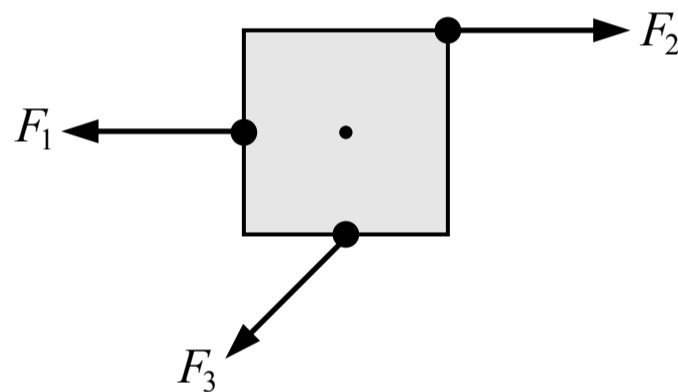

12. Three forces with equal magnitude are exerted on a square which is free to rotate about the point at its center as shown in the figure above. How do the magnitudes of the torques produced by the three forces about the center compare?

- (A) $\tau_1 = \tau_2 = \tau_3$
- (B) $\tau_1 < \tau_2 < \tau_3$
- (C) $\tau_3 < \tau_1 = \tau_2$
- (D) $\tau_1 < \tau_3 < \tau_2$



13. Block A is held in place against a spring which is initially compressed a distance of Δx_0 from its original length. Block A is then released, moves to the right and loses contact with the spring. Block A slides across the surface where friction is negligible and it collides and sticks to block B which is initially at rest. Which of the following is an expression for the speed of the blocks after the collision?

- (A) $\sqrt{\frac{k_0 \Delta x_0^2}{m_0}}$
- (B) $\frac{1}{3} \sqrt{\frac{k_0 \Delta x_0^2}{m_0}}$
- (C) $\frac{1}{2} \sqrt{\frac{k_0 \Delta x_0^2}{m_0}}$
- (D) 0

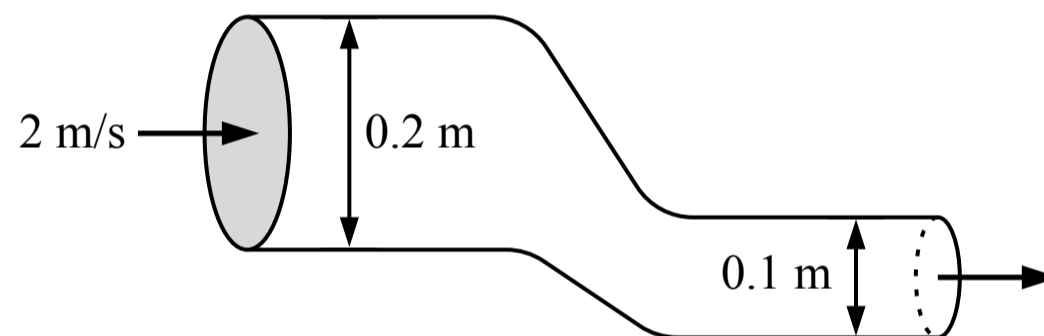

14. An ideal fluid is flowing into the tube shown in the figure above with a speed of 2 m/s. The diameter of the inlet is 0.2 m and the diameter of the outlet is 0.1 m. The volume of fluid that exits the tube over a period of 3 seconds is most nearly
- (A) 0.19 m³
- (B) 0.06 m³
- (C) 0.09 m³
- (D) 0.38 m³

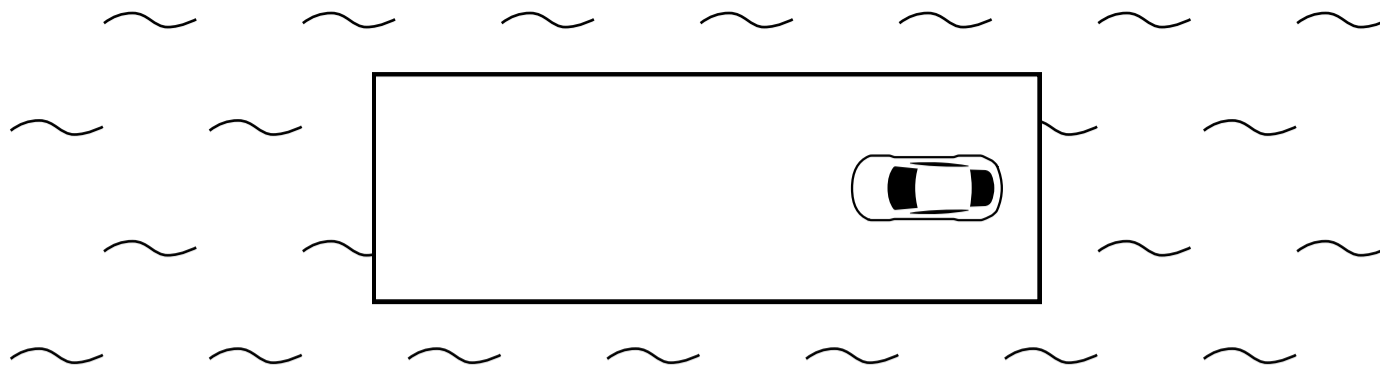

15. A car is at rest on a raft which is floating at rest in the water as shown in the top-down view in the figure above. The raft can slide through the water and the friction between the raft and the water is negligible. The car then drives to the left end of the raft and stops. After the car stops, which of the following is true?
- (A) The raft and the car are moving to the left
 - (B) The raft and the car are moving to the right
 - (C) The raft and the car are not moving
 - (D) The final motion of the raft and the car cannot be determined without knowing their masses

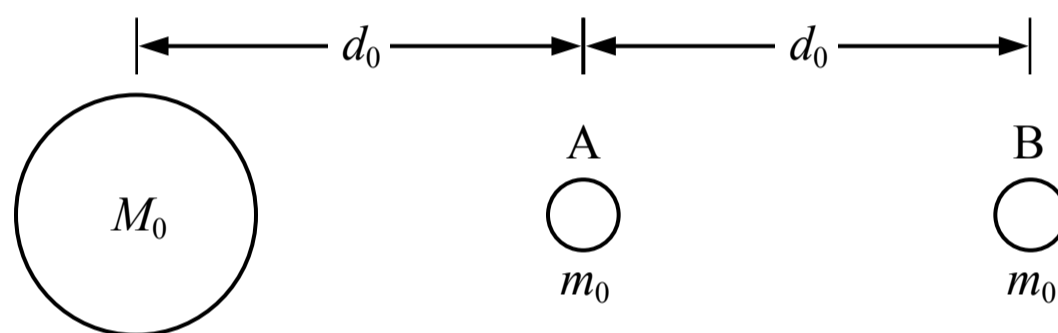

16. A planet has two moons which have the same mass and are located at the positions shown in the figure above. Which system, consisting of the planet and either one of the moons, has a greater gravitational potential energy?
- (A) The planet-moon A system has a greater gravitational potential energy
 - (B) The planet-moon B system has a greater gravitational potential energy
 - (C) The systems have the same gravitational potential energy
 - (D) Cannot be determined

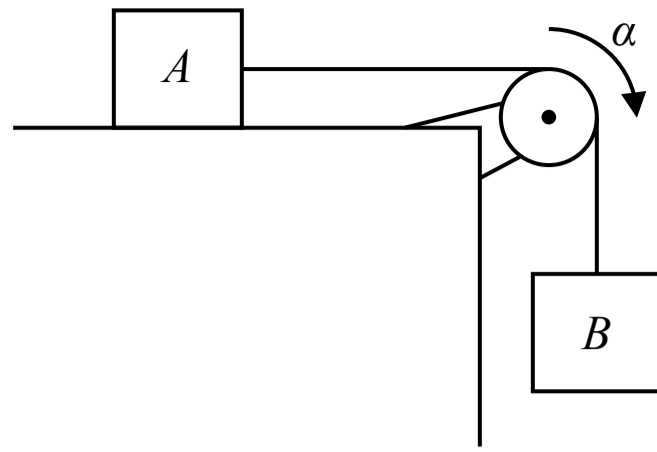

17. Two blocks are connected by a string that passes over a pulley as shown in the figure above. The blocks are released from rest, block B falls and the pulley experiences an angular acceleration. Which of the following graphs could represent the magnitude of the angular displacement of the pulley over time?

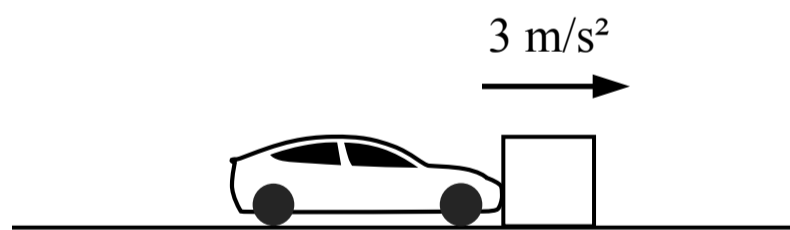
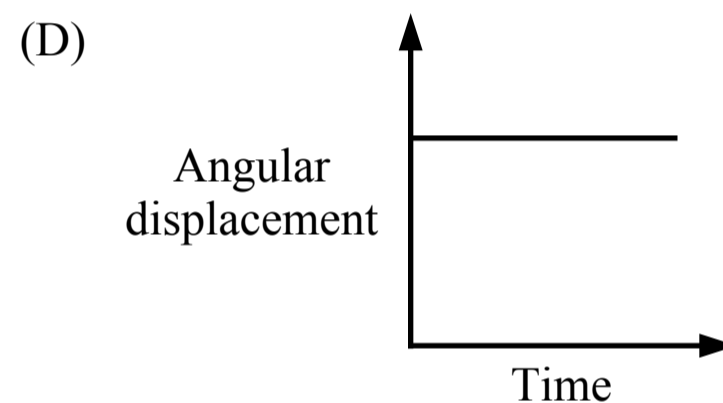
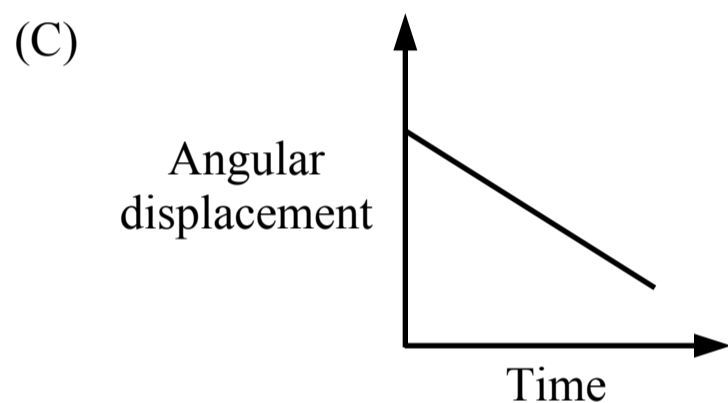
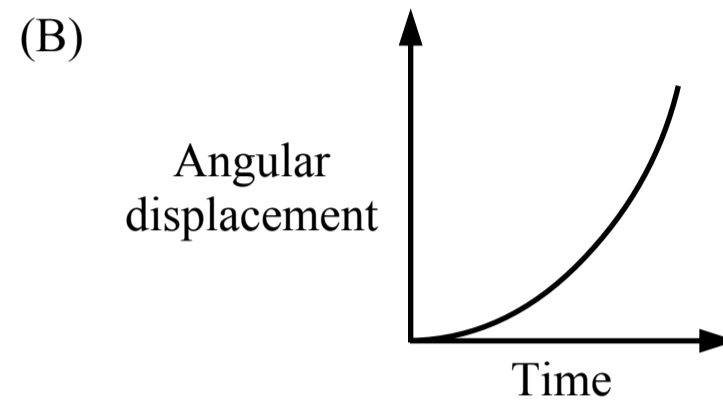
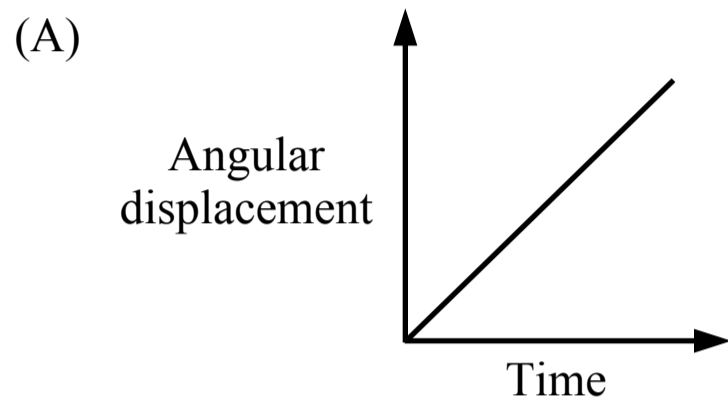

18. A car pushes a large block across a surface where friction is not negligible and the block accelerates at 3 m/s^2 . Which of the following statements is true?

- (A) The block does not exert a force on the car
- (B) The force exerted on the block by the car is greater in magnitude than the force exerted on the car by the block
- (C) The force exerted on the block by the car is smaller in magnitude than the force exerted on the car by the block
- (D) The force exerted on the block by the car is equal in magnitude to the force exerted on the car by the block

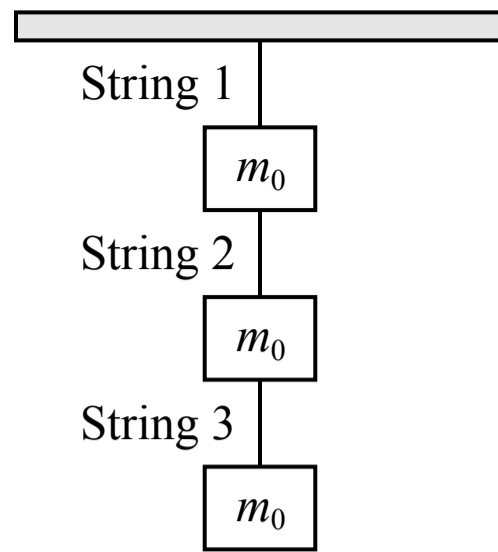

19. Three blocks with equal mass are suspended from the ceiling using three strings as shown in the figure above. If string 1 is cut, which of the following is an expression for the tension in string 2?

- (A) 0
- (B) $m_0 g$
- (C) $2 m_0 g$
- (D) $3 m_0 g$

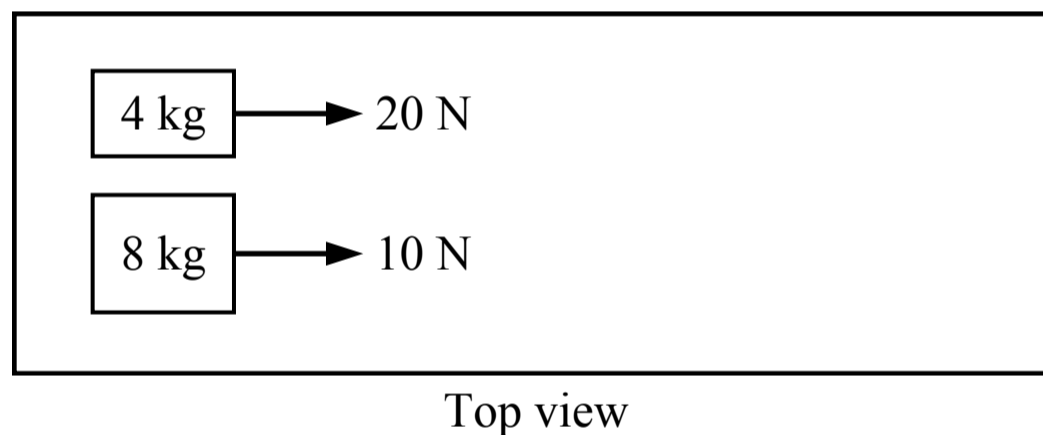

20. Two blocks are initially at rest on a table where the friction is negligible. A force is then applied to each block as shown in the figure above. Which block has a momentum with a greater magnitude after 3 seconds?

- (A) The 4 kg block
- (B) The 8 kg block
- (C) The blocks have momentums with equal magnitudes
- (D) Cannot be determined

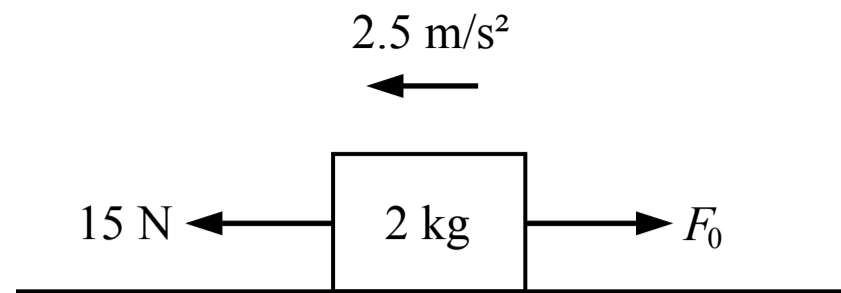

Note: Figure not drawn to scale.

21. A 2 kg block slides along a frictionless surface as shown in the figure above with an acceleration of 2.5 m/s^2 . Two horizontal forces are acting on the block. What is the magnitude of force F_0 ?

- (A) 20 N
- (B) 10 N
- (C) 15 N
- (D) 5 N

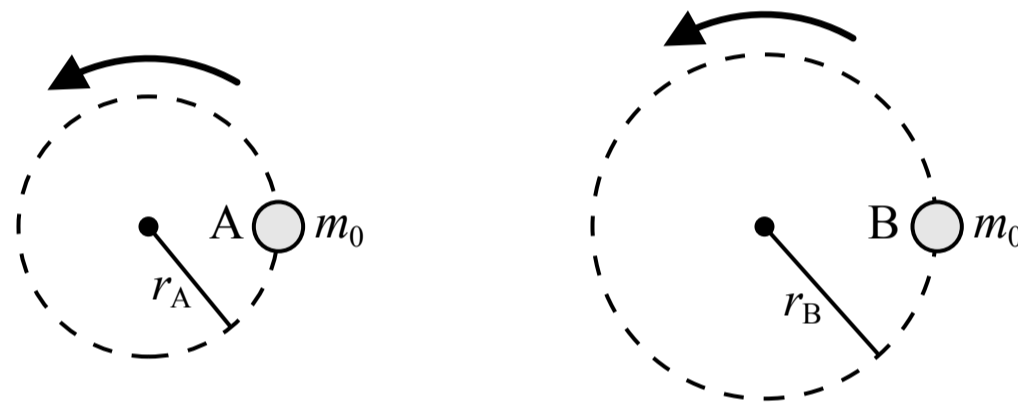

22. Two objects with the same mass are in uniform circular motion. Object A follows a circular path with radius r_A and object B follows a circular path with a radius of $r_B > r_A$. If the period of each object's circular motion is the same, the magnitude of the net force acting on object A is

- (A) equal to the net force acting on object B
- (B) less than the net force acting on object B
- (C) greater than the net force acting on object B
- (D) a comparison between the net force on object A and object B cannot be determined

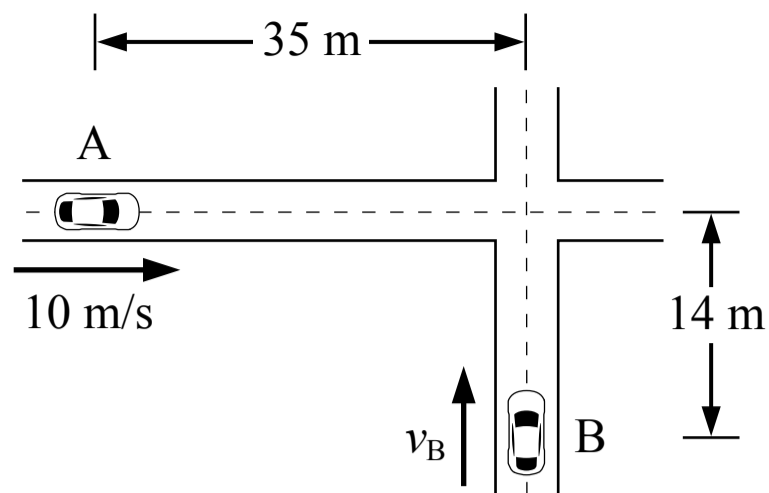

Note: Figure not drawn to scale.

23. Two cars are approaching an intersection as shown in the figure above. Car A is moving at a constant speed of 10 m/s and car B is moving at a constant speed v_B . At time t_0 car A is 35 m from the middle of the intersection and car B is 14 m from the middle of the intersection. What constant speed v_B would result in the cars colliding in the intersection? You may disregard the width and length of each car and treat the cars as point masses.

- (A) 4 m/s
- (B) 10 m/s
- (C) 3.5 m/s
- (D) 8 m/s

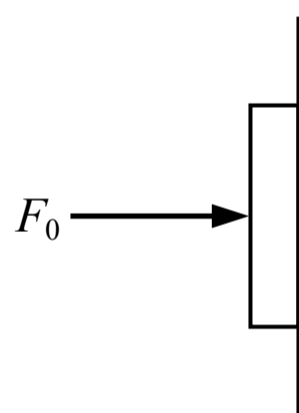

24. A person pushes horizontally on a book which is against a wall so that the book remains at rest. Which of the following shows the direction of the friction force acting on the book from the wall?

- (A) ←
- (B) ↓
- (C) →
- (D) ↑

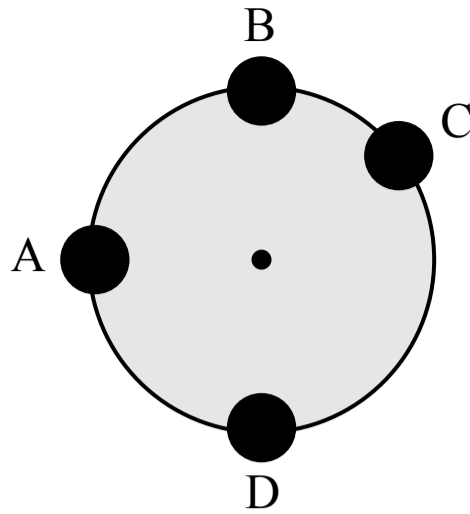

25. A large vertical wheel with uniform mass M is free to rotate on a horizontal axle passing through its center. A small sphere of mass m is attached to the outer edge of the wheel. At which of the locations shown should the small sphere be attached so that the total torque produced by the wheel and the sphere about the axle is greatest?

- (A) Location A
- (B) Location B
- (C) Location C
- (D) Location D



26. Two blocks are sliding towards each other on a surface with negligible friction. The blocks collide, stick together and continue moving after the collision. Which of the following graphs shows the total kinetic energy of the two block system over time?

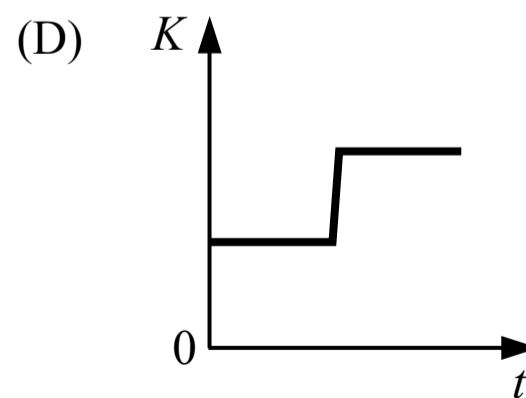
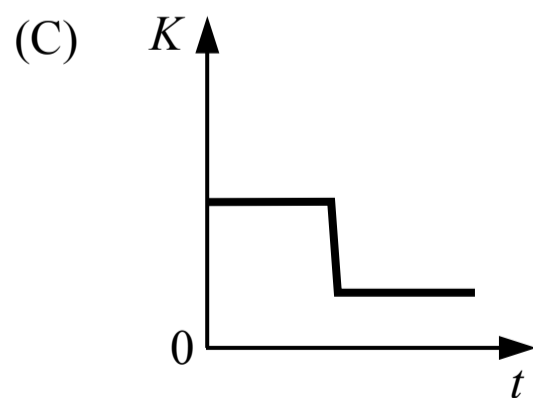
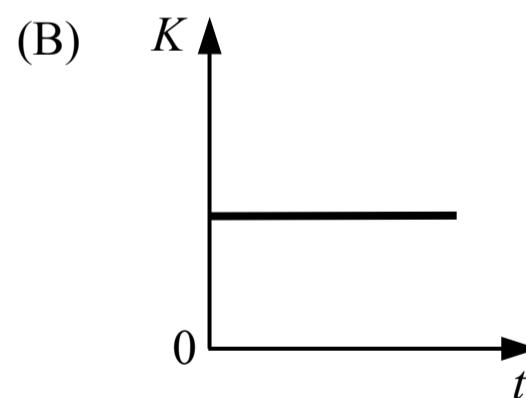
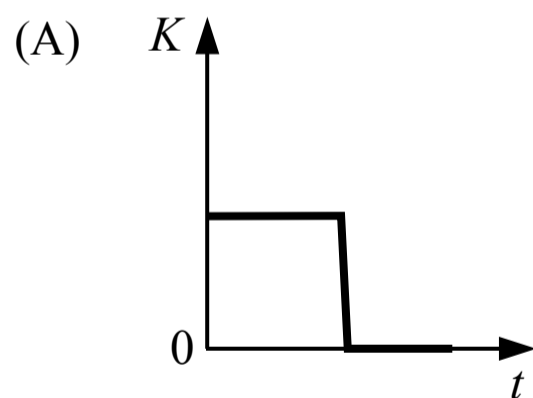

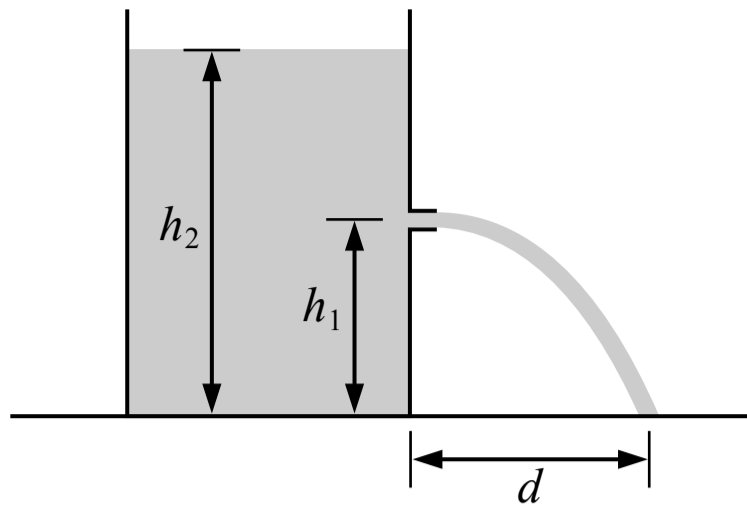

27. A large tank of oil is open at the top and has a hole in the side as shown in the figure above. A stream of oil exits the hole horizontally and then lands on the ground a distance of d from the base of the tank. The hole is at a height of h_1 and the top surface of the oil is at a height of h_2 . Which of the following is a correct expression for the distance d that the oil stream lands away from the tank?

- (A) $\sqrt{\frac{2h_1}{g}}$
 (B) $\sqrt{2g(h_2 - h_1)}$
 (C) $\sqrt{4h_1(h_2 - h_1)}$
 (D) $\sqrt{4(h_2 - h_1)}$

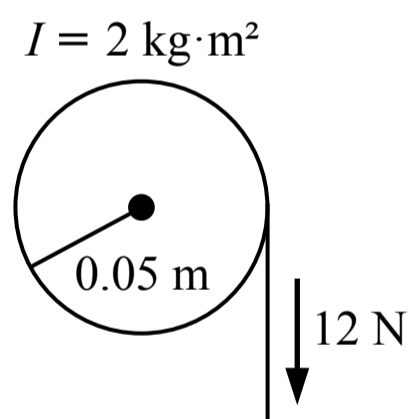

28. A string with negligible mass is wrapped around the outside of a pulley with a rotational inertia of $2 \text{ kg}\cdot\text{m}^2$ and a radius of 0.05 m as shown in the figure above. The pulley is initially at rest when a constant 12 N force is applied to the string. The angular momentum of the pulley after a period of 3 seconds is most nearly

- (A) $3.6 \text{ kg}\cdot\text{m}^2/\text{s}$
 (B) $0.9 \text{ kg}\cdot\text{m}^2/\text{s}$
 (C) $0.6 \text{ kg}\cdot\text{m}^2/\text{s}$
 (D) $1.8 \text{ kg}\cdot\text{m}^2/\text{s}$

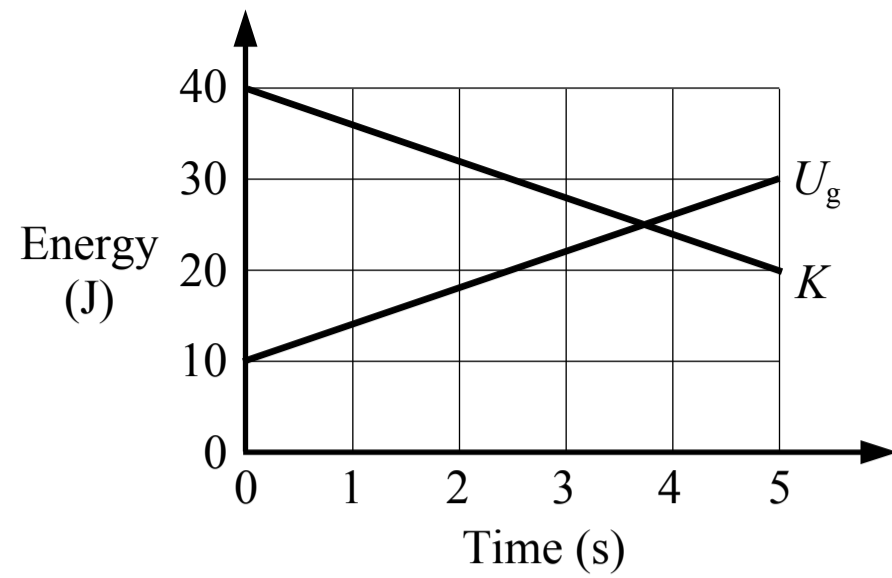

29. A graph of the energy in a system, which only has kinetic energy and gravitational potential energy, is shown in the figure above. Which of the following statements is true about this system from 0 s to 5 s?

- (A) 20 J of work is done on the system
- (B) 30 J of work is done on the system
- (C) 50 J of work is done on the system
- (D) No work is done on the system

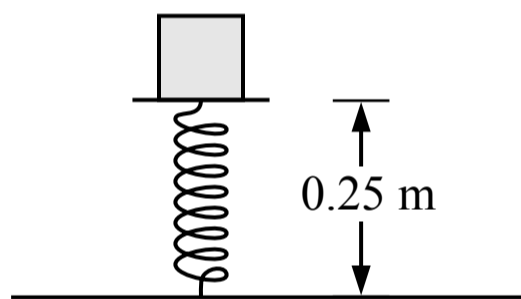

30. A block sits at rest on a spring which has a spring constant of 400 N/m and an unstretched length of 0.30 m. The block is compressing the spring as shown in the figure above. The mass of the block is most nearly

- (A) 20 kg
- (B) 12 kg
- (C) 10 kg
- (D) 2 kg

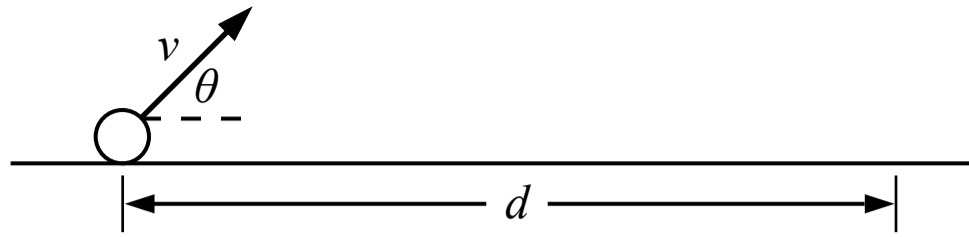

31. A projectile is launched from the ground with an initial speed and angle as shown in the figure above. It travels a distance d and lands on the ground. The projectile is launched five times with the same speed but five different angles: $\theta_1 = 52^\circ$, $\theta_2 = 38^\circ$, $\theta_3 = 45^\circ$, $\theta_4 = 32^\circ$, $\theta_5 = 60^\circ$. It lands at distances d_1 , d_2 , d_3 , d_4 and d_5 respectively. How do the distances compare to each other?

- (A) $d_4 < d_2 < d_3 < d_1 < d_5$
 (B) $d_5 < d_1 < d_3 < d_2 < d_4$
 (C) $d_5 < d_4 < d_1 = d_2 < d_3$
 (D) $d_5 < d_1 = d_4 < d_2 < d_3$

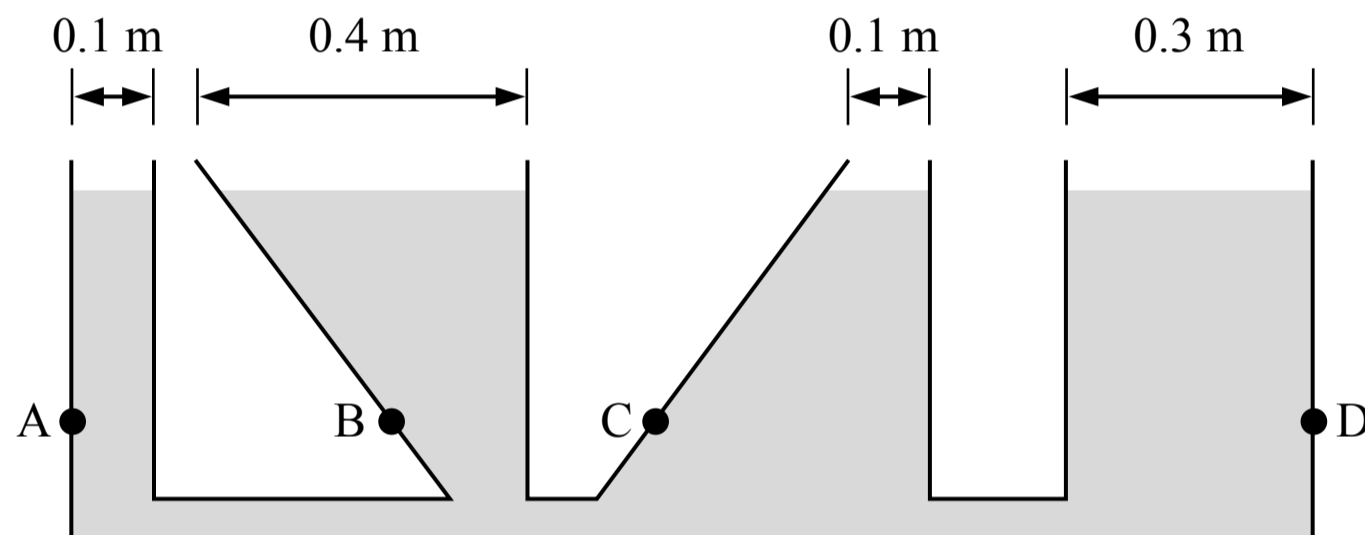

32. A large container is mostly filled with a liquid and is open at the top as shown in the figure above. The four points shown are at the same height above the bottom of the container. Which of the following correctly ranks the pressure exerted on the wall of the container by the liquid at the four points shown?

- (A) $P_A = P_B = P_C = P_D$
 (B) $(P_A = P_C) < P_D < P_B$
 (C) $P_B < P_D < (P_A = P_C)$
 (D) $P_C < (P_A = P_D) < P_B$

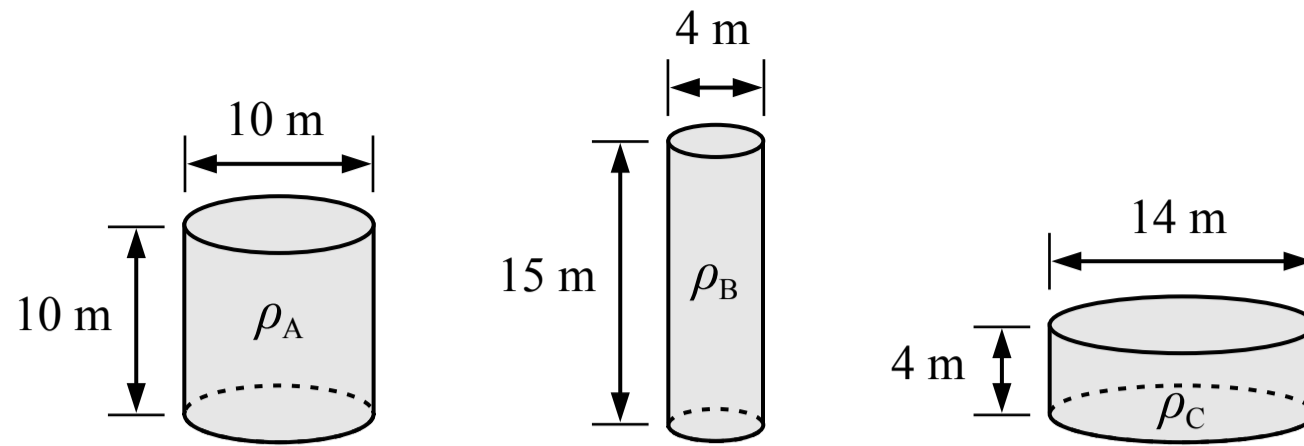

33. The heights and diameters of three cylinders are shown in the figure above. All three cylinders are filled with the same mass of gas. Which of the following correctly relates the densities of the gas in each cylinder?

- (A) $\rho_C < \rho_A < \rho_B$
- (B) $\rho_B < \rho_C < \rho_A$
- (C) $\rho_A < \rho_C < \rho_B$
- (D) $\rho_A = \rho_B = \rho_C$

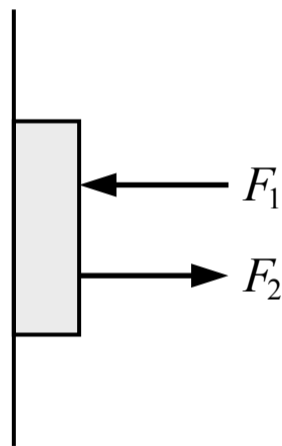

34. A book is at rest against a wall with two forces acting on it as shown in the figure above. Which of the following represent the magnitude of the force acting on the book by the wall?

- (A) $F_2 - F_1$
- (B) $F_1 + F_2$
- (C) $F_1 - F_2$
- (D) $-F_1 - F_2$

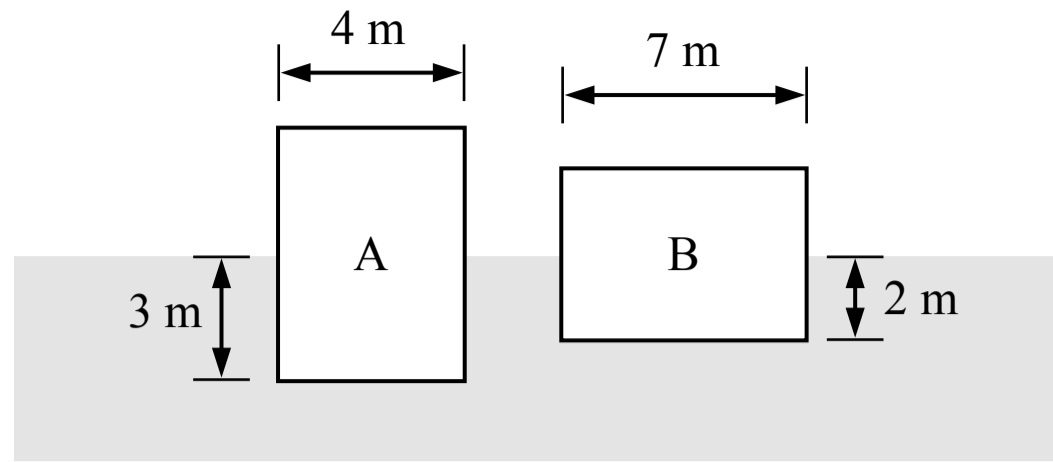

Note: Figure not drawn to scale.

35. Two solid blocks are floating at rest in a liquid as shown in the figure above. The blocks have the same thickness (the dimension into/out of the page). Which of the two blocks has a greater mass?

- (A) Block A
- (B) Block B
- (C) They have the same mass
- (D) Cannot be determined

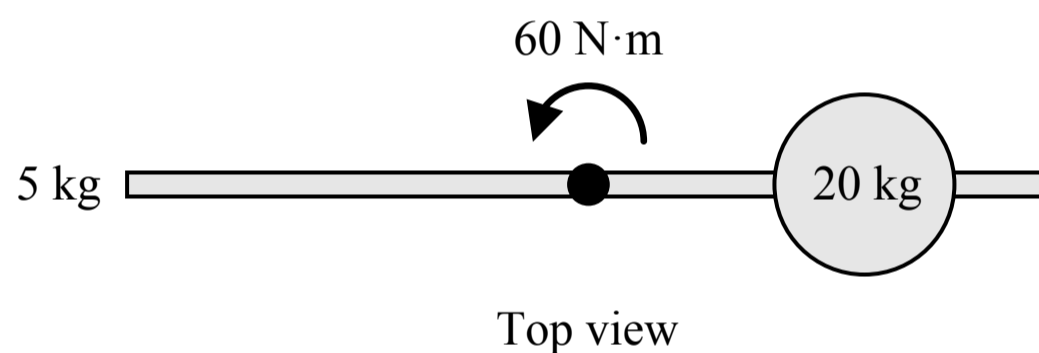

36. A 20 kg sphere is attached to a 5 kg rod which is free to rotate about its center as shown in the figure above. A 60 N·m torque is applied to the rod by a force which is not shown, and the rod and sphere rotate with an angular acceleration. Which of the following changes would increase the angular acceleration of the rod and sphere?

- (A) Decrease the mass of the rod
- (B) Move the sphere farther from the center of the rod
- (C) Increase the mass of the sphere
- (D) Increase the total length of the rod so the total mass of the rod remains the same and it rotates about its center

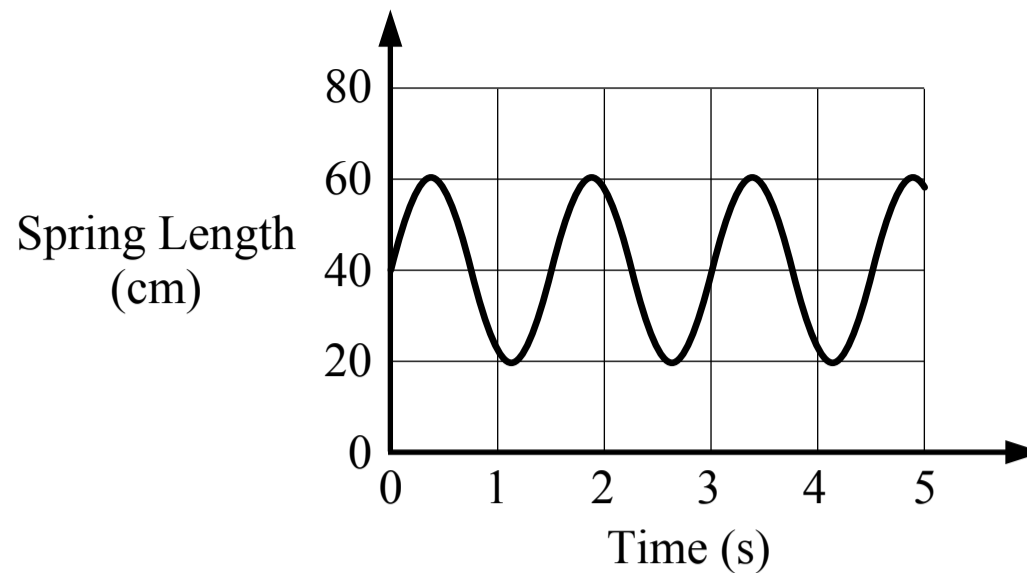
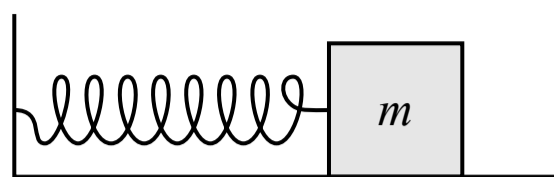

37. A block is attached to a spring with a spring constant of 50 N/m as shown in the figure above. The block is oscillating back and forth on a surface with negligible friction and the length of the spring over time is shown in the graph above. The mass of the block is most nearly

- (A) 112.5 kg
- (B) 11.4 kg
- (C) 2.8 kg
- (D) 0.7 kg

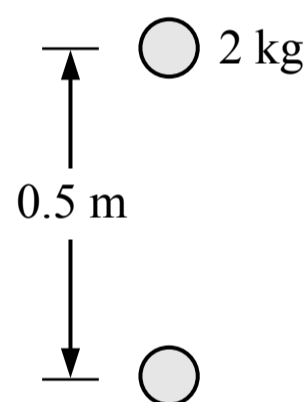

38. A person is holding a ball with a mass of 2 kg in the air at rest. They lower the ball a distance of 0.5 m at a constant speed and bring it to rest again at the lower height. Which of the following is true about the ball system between the initial and final heights?

- (A) The person does positive work on the system
- (B) The total energy of the system does not change
- (C) Gravity does zero work on the system
- (D) The total energy of the system decreases

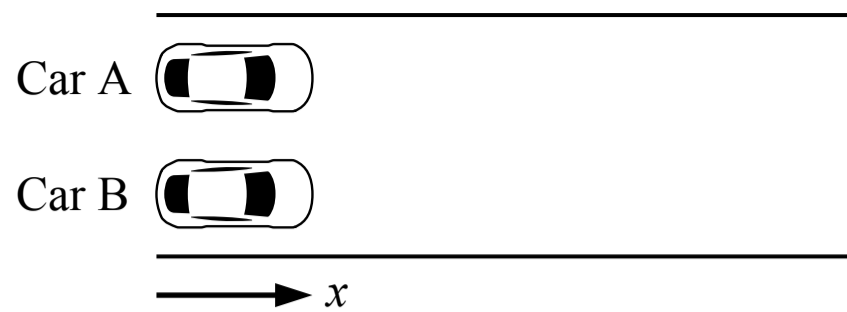

39. Two cars are stopped next to each other on a straight road as shown in the figure above. At the same starting time, car A drives forward with a constant speed of 10 m/s and car B accelerates forward at 2 m/s^2 . How far apart are the two cars (in the x direction) after 5 seconds?

- (A) 115 m
- (B) 25 m
- (C) 40 m
- (D) 100 m

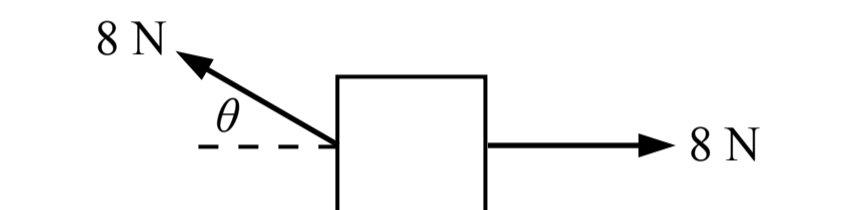

40. A block is sitting at rest on a surface with negligible friction when two forces are applied to the block as shown in the figure above. If the block remains in contact with the surface, which of the following graphs shows the motion of the block starting when the forces are applied?

