

CONSERVATION OF ENERGY

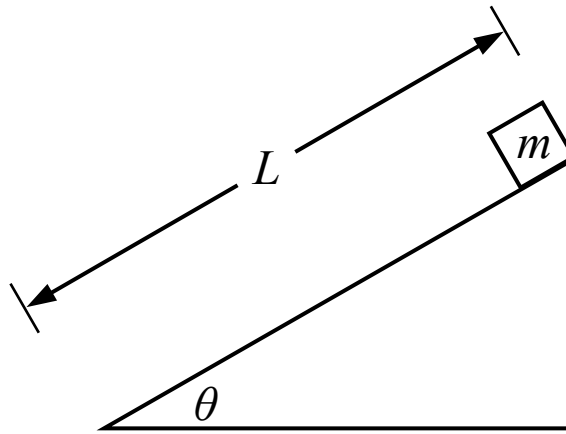

1. A small block of mass m starts at rest at the top of an incline with a length of L . The block slides down the incline and the coefficient of kinetic friction between the block and the incline is μ_k . Which of the following is a correct expression for the speed of the block at the bottom of the incline?

- (A) $\sqrt{2gL \sin(\theta) - 2gL\mu_k \cos(\theta)}$
- (B) $mgL \sin(\theta) - mgL\mu_k \cos(\theta)$
- (C) $\sqrt{2gL \sin(\theta)}$
- (D) $mgL \sin(\theta)$

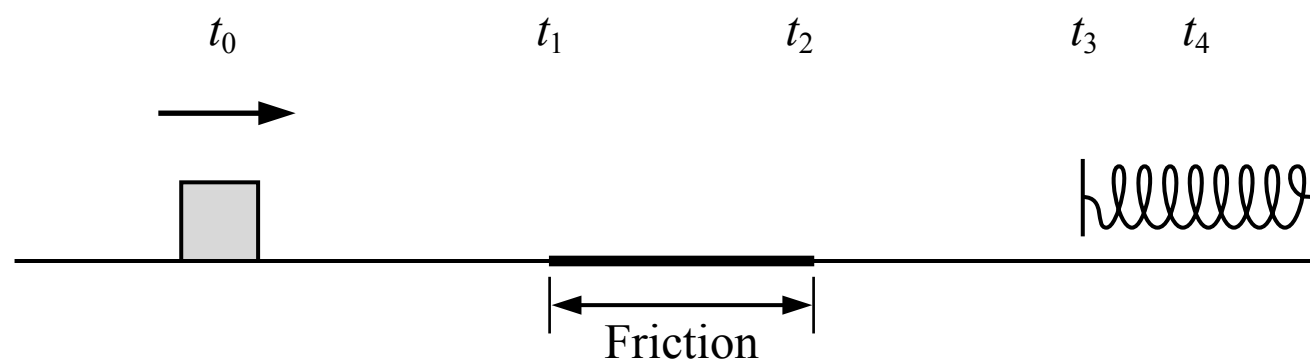

2. A block is sliding across a surface with negligible friction at a constant speed at time t_0 . The block then slides over a patch where friction acts on the block from time t_1 to time t_2 . The block then again slides across a surface with negligible friction from time t_2 to time t_3 . The block comes into contact with a spring at time t_3 and compresses the spring until the block momentarily comes to rest at time t_4 . Which of the following graphs show the total energy of the block-spring system over time?

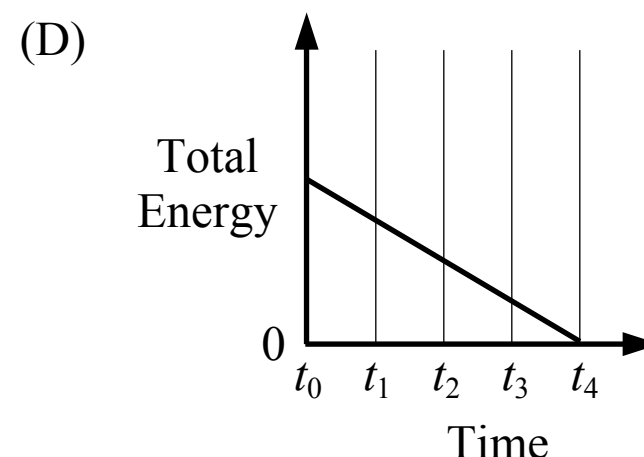
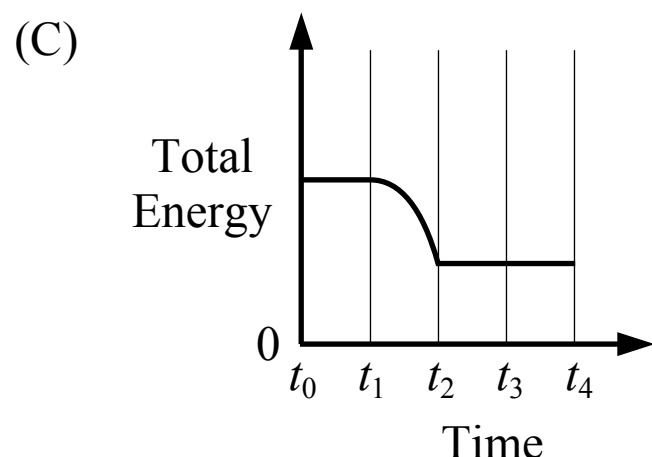
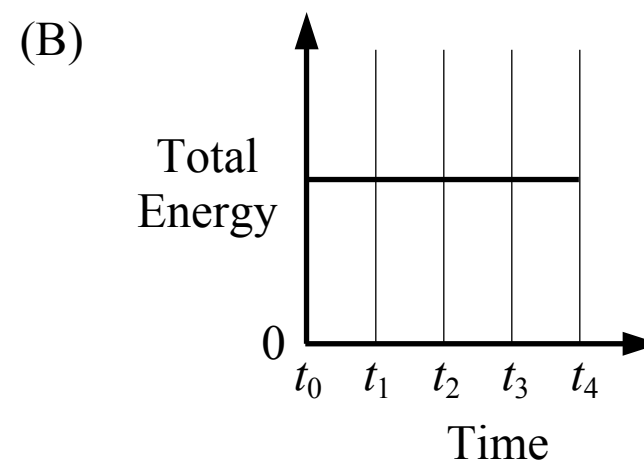
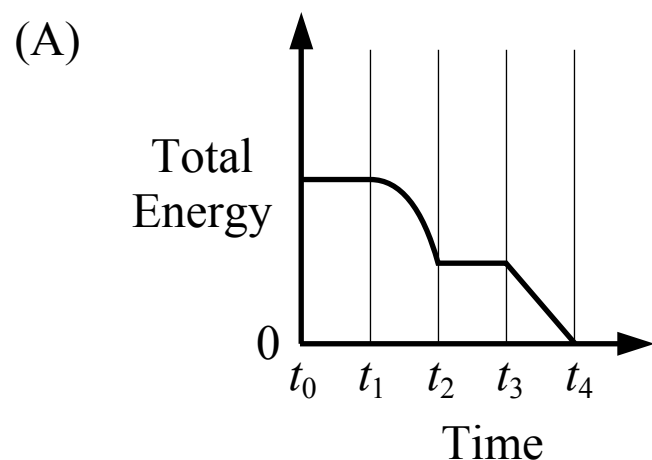

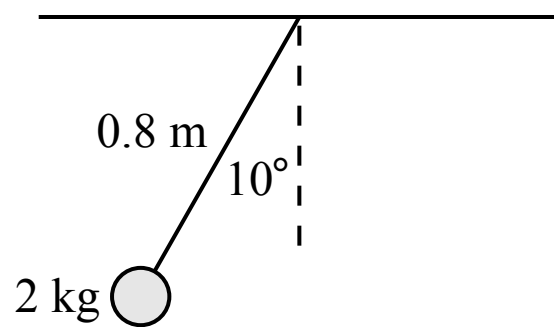

Note: Figure not drawn to scale.

3. A 2 kg sphere is attached to a 0.8 m long cable with negligible mass to form a pendulum as shown in the figure above. The pendulum is released from rest at the position shown. The speed of the sphere at the lowest point in the motion is most nearly

- (A) 4.0 m/s
 (B) 0.5 m/s
 (C) 3.6 m/s
 (D) 1.7 m/s

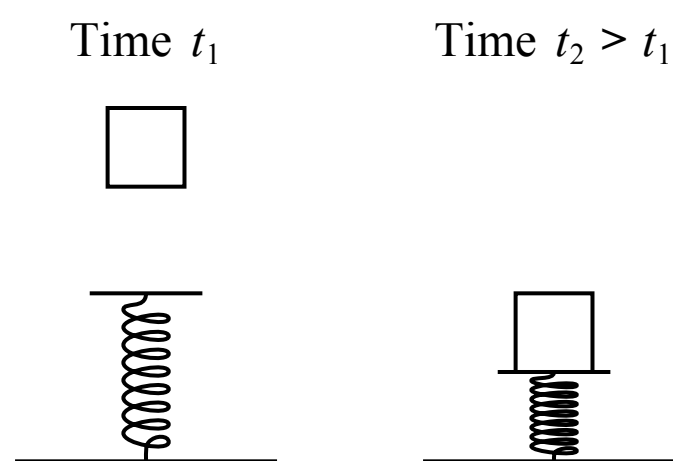

4. A block is released from rest at a height above an uncompressed spring at time t_1 . The block falls and compresses the spring, and momentarily comes to rest at time t_2 . Which of the following correctly compares the total energy of the following systems at time t_1 and time t_2 ?

(A)

Block System	Block-Earth System	Block-Spring System
$E_1 < E_2$	$E_1 > E_2$	$E_1 < E_2$

(B)

Block System	Block-Earth System	Block-Spring System
$E_1 = E_2$	$E_1 = E_2$	$E_1 = E_2$

(C)

Block System	Block-Earth System	Block-Spring System
$E_1 > E_2$	$E_1 < E_2$	$E_1 > E_2$

(D)

Block System	Block-Earth System	Block-Spring System
$E_1 = E_2$	$E_1 > E_2$	$E_1 < E_2$

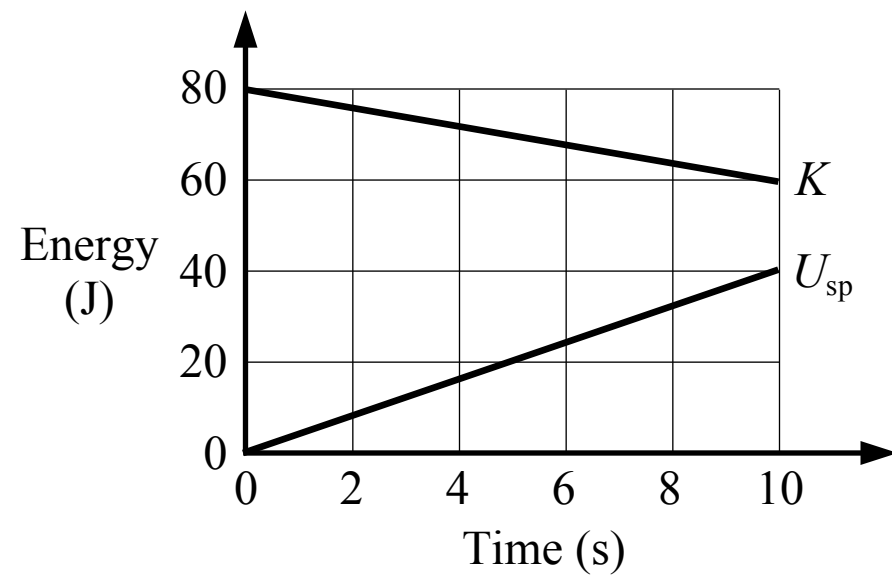

5. A graph of the energy in a system, which only has kinetic energy and spring potential energy, is shown in the figure above. Which of the following is true about this system?

- (A) There are no external forces acting on the system
- (B) There must be at least one external force acting on the system
- (C) There must be a friction force acting on the system
- (D) It cannot be determined if there are any external forces acting on the system

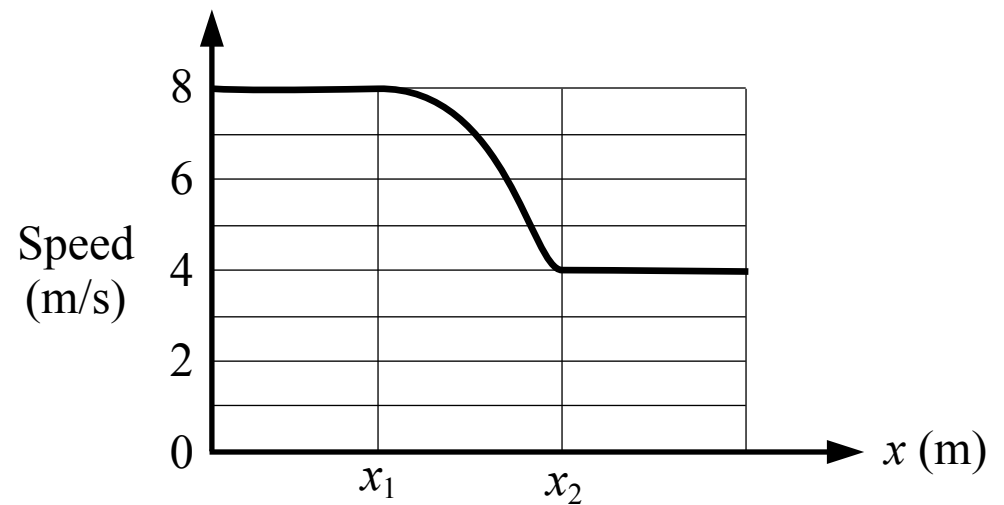
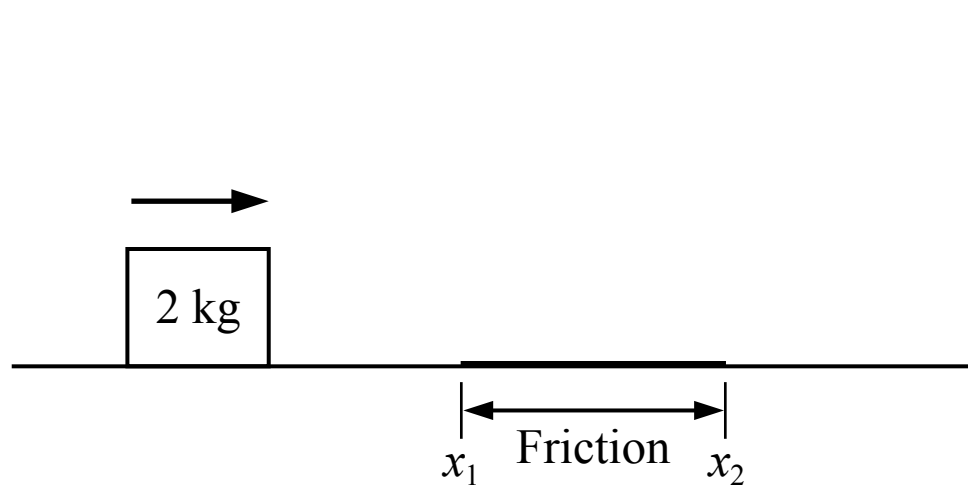

6. A block is sliding across a surface with negligible friction except for the length of surface between x_1 and x_2 . A graph of the block's motion is shown in the figure above. The work done on the block by friction is most nearly

- (A) -48 J
- (B) -16 J
- (C) -64 J
- (D) Cannot be determined

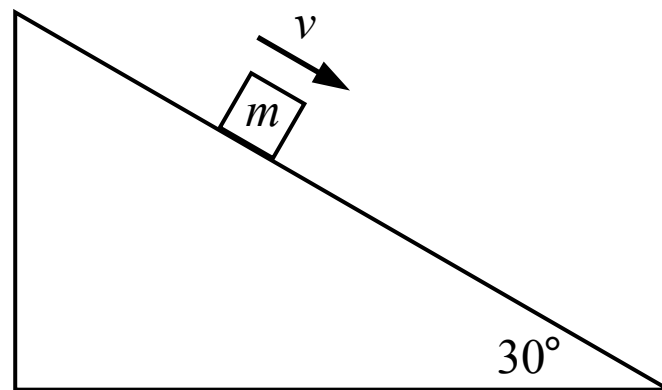

7. A block slides down an incline with a constant speed as shown in the figure above. The friction between the incline and the block is not negligible. Which of the following statements is true about the work done on the block?
- (A) The magnitude of the work done by gravity is equal to the magnitude of the work done by friction
 - (B) The magnitude of the work done by friction is equal to the magnitude of the work done by the normal force
 - (C) The magnitude of the work done by gravity is greater than the magnitude of the work done by friction
 - (D) The magnitude of the work done by gravity is equal to the magnitude of the work done by the normal force

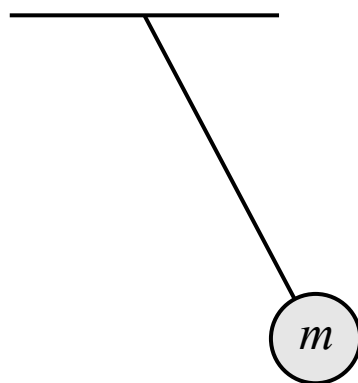

8. A pendulum consists of a sphere of mass m attached to a string with negligible mass. As the pendulum swings back and forth, which of the following statements is true?
- (A) The total kinetic energy of the sphere-earth system is constant
 - (B) The total energy of the sphere-earth system is constant
 - (C) The total gravitational potential energy of the sphere-earth system is constant
 - (D) All of the above

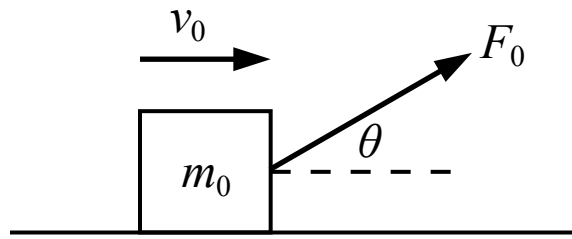

9. A block is sliding on a surface with negligible friction with a speed of v_0 when a force is applied to the block as shown in the figure above. When the block has moved a distance of d_0 it has kinetic energy K_0 . If the motion was repeated with a greater value of θ and no other changes, the kinetic energy of the block after moving a distance of d_0 would be
- (A) less than K_0
 - (B) greater than K_0
 - (C) equal to K_0
 - (D) Cannot be determined

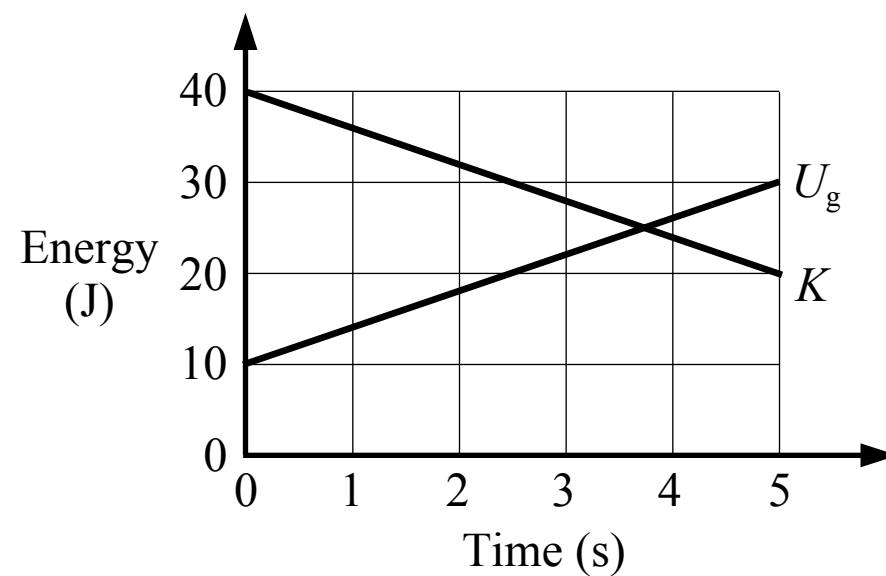

10. A graph of the energy in a system, which only has kinetic energy and gravitational potential energy, is shown in the figure above. Which of the following statements is true about this system from 0 s to 5 s?
- (A) 20 J of work is done on the system
 - (B) 30 J of work is done on the system
 - (C) 50 J of work is done on the system
 - (D) No work is done on the system

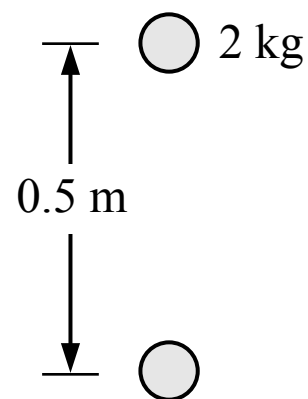

11. A person is holding a ball with a mass of 2 kg in the air at rest. They lower the ball a distance of 0.5 m at a constant speed and bring it to rest again at the lower height. Which of the following is true about the ball system between the initial and final heights?

- (A) The person does positive work on the system
- (B) The total energy of the system does not change
- (C) Gravity does zero work on the system
- (D) The total energy of the system decreases

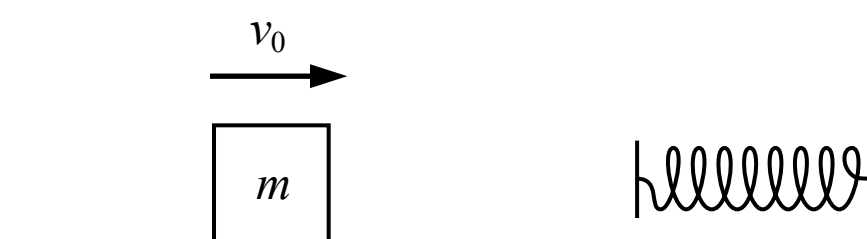

12. A block is sliding across a surface where the friction is not negligible. The block has an initial speed of v_0 at time t_0 . The block then collides with a spring and momentarily comes to a stop at time t_1 . Which of the following is true about the block-spring system from time t_0 to time t_1 ?

- (A) The spring does positive work on the system
- (B) The total energy of the system is constant
- (C) The spring does negative work on the system
- (D) The total energy of the system decreases

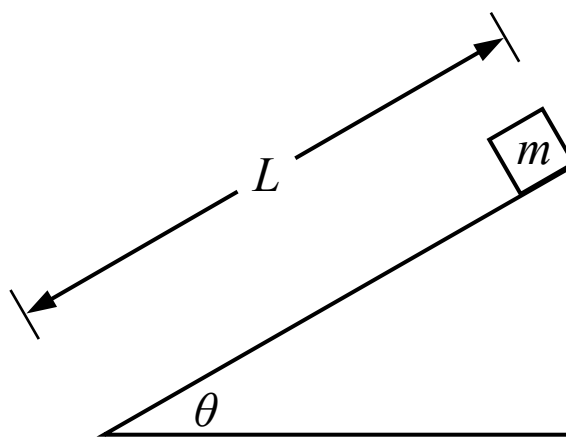

1. A small block of mass m starts at rest at the top of an incline with a length of L . The block slides down the incline and the coefficient of kinetic friction between the block and the incline is μ_k . Which of the following is a correct expression for the speed of the block at the bottom of the incline?

(A) $\sqrt{2gL \sin(\theta) - 2gL\mu_k \cos(\theta)}$

(B) $mgL \sin(\theta) - mgL\mu_k \cos(\theta)$

(C) $\sqrt{2gL \sin(\theta)}$

(D) $mgL \sin(\theta)$

A Correct

The change in the total energy of the block-earth system between the times when the block is at the top and the bottom of the incline is equal to the work done on the block by the friction force from the incline. The block has no kinetic energy at the top of the incline and we can establish the reference height for zero gravitational potential energy at the bottom of the incline. The work done by the friction force is negative.

$$E_f - E_i = W \quad K_f - U_{gi} = -f_k L \quad \frac{1}{2} m v_f^2 - mgL \sin(\theta) (\mu_k mg \cos(\theta)) L$$

$$v_f = \sqrt{2gL \sin(\theta) - 2gL\mu_k \cos(\theta)}$$

B Incorrect

This answer is the kinetic energy of the block at the bottom of the incline.

C Incorrect

This answer would be the final speed of the block if there was no friction force doing work on the block.

D Incorrect

This answer is the gravitational potential energy of the block-earth system when the block is at the top of the incline.

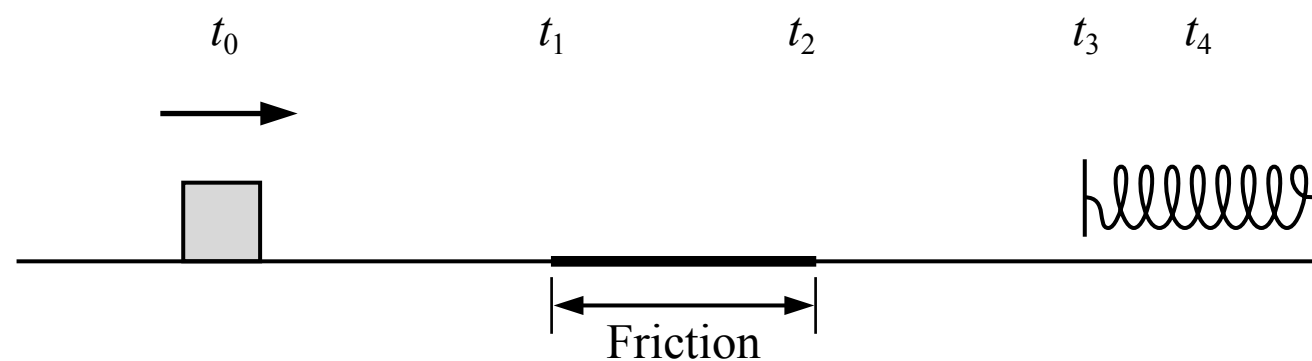

2. A block is sliding across a surface with negligible friction at a constant speed at time t_0 . The block then slides over a patch where friction acts on the block from time t_1 to time t_2 . The block then again slides across a surface with negligible friction from time t_2 to time t_3 . The block comes into contact with a spring at time t_3 and compresses the spring until the block momentarily comes to rest at time t_4 . Which of the following graphs show the total energy of the block-spring system over time?

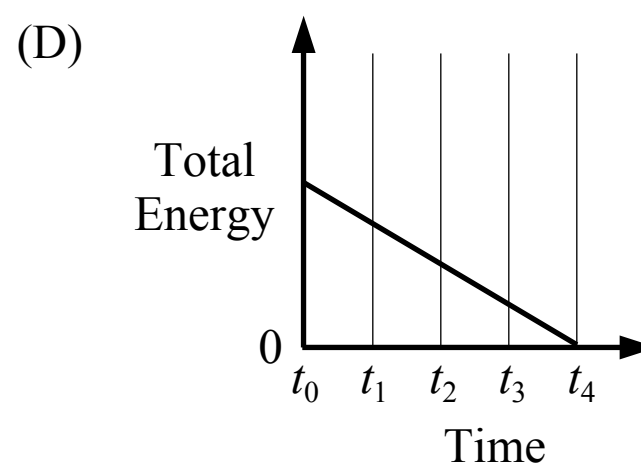
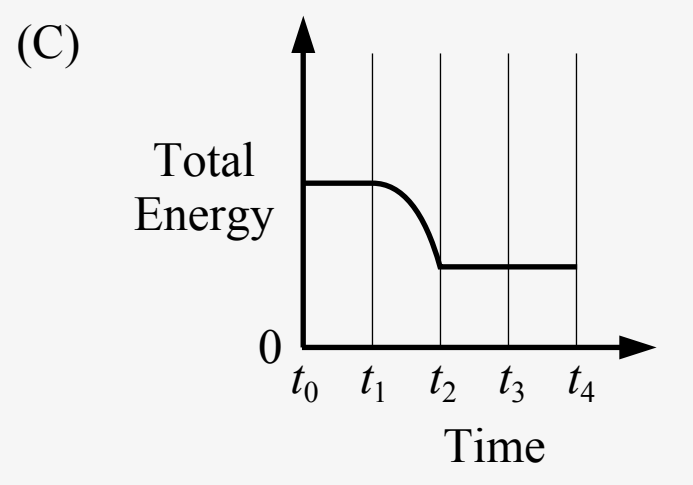
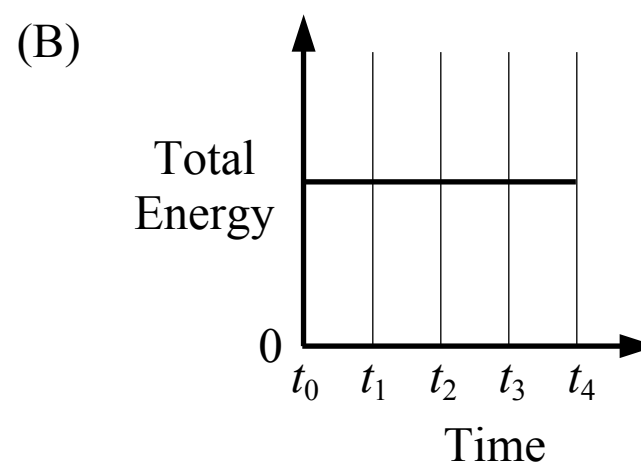
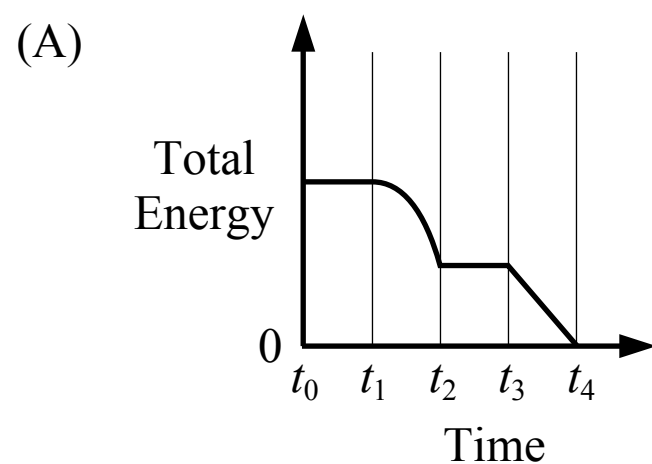

(A) Incorrect

(B) Incorrect

(C) Correct

The block-spring system has kinetic energy and spring potential energy in this scenario. From t_0 to t_1 the block has a constant speed and constant kinetic energy. From t_1 to t_2 there is a friction force acting on the block which does negative work on the system so the system loses energy (kinetic energy). From t_2 to t_3 the block has a constant speed and constant kinetic energy. From t_3 to t_4 kinetic energy is converted into spring potential energy, but the system includes the block and the spring so energy is conserved.

(D) Incorrect

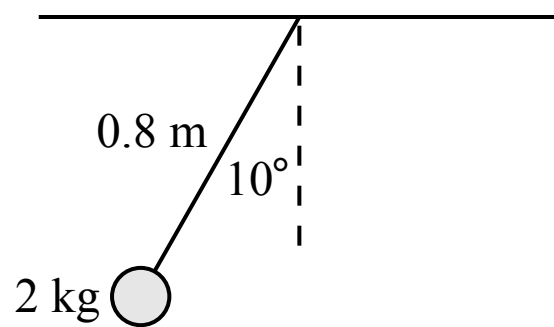

Note: Figure not drawn to scale.

3. A 2 kg sphere is attached to a 0.8 m long cable with negligible mass to form a pendulum as shown in the figure above. The pendulum is released from rest at the position shown. The speed of the sphere at the lowest point in the motion is most nearly

- (A) 4.0 m/s
 (B) 0.5 m/s
 (C) 3.6 m/s
 (D) 1.7 m/s

(A) Incorrect

This answer incorrectly uses 0.8 m for the change in height of the sphere.

(B) **Correct**

The total energy of the sphere-earth system is conserved (the tension force from the cable acts perpendicular to the velocity of the sphere so it does not do work on the system). The sphere has no kinetic energy at the position shown since the sphere is at rest, and we can establish the reference height for zero gravitational potential energy when the sphere is at the lowest point in the motion.

$$E_i = E_f \quad U_{gi} = K_f \quad mgh = \frac{1}{2}mv^2 \quad g((0.8 \text{ m}) - (0.8 \text{ m})\cos(10^\circ)) = \frac{1}{2}v^2 \quad v = 0.5 \text{ m/s}$$

(C) Incorrect

This answer incorrectly uses $\sin(10^\circ)$ instead of $\cos(10^\circ)$ in the expression for the change in height.

(D) Incorrect

This answer incorrectly uses $(0.8 \text{ m})\sin(10^\circ)$ for the change in height of the sphere.

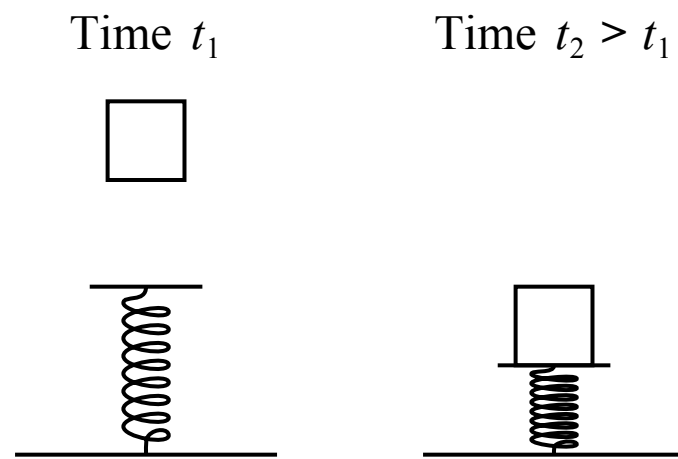

4. A block is released from rest at a height above an uncompressed spring at time t_1 . The block falls and compresses the spring, and momentarily comes to rest at time t_2 . Which of the following correctly compares the total energy of the following systems at time t_1 and time t_2 ?

(A)

Block System	Block-Earth System	Block-Spring System
$E_1 < E_2$	$E_1 > E_2$	$E_1 < E_2$

(B)

Block System	Block-Earth System	Block-Spring System
$E_1 = E_2$	$E_1 = E_2$	$E_1 = E_2$

(C)

Block System	Block-Earth System	Block-Spring System
$E_1 > E_2$	$E_1 < E_2$	$E_1 > E_2$

(D)

Block System	Block-Earth System	Block-Spring System
$E_1 = E_2$	$E_1 > E_2$	$E_1 < E_2$

(A) Incorrect

(B) Incorrect

(C) Incorrect

(D) Correct

The block system has zero kinetic energy at both times because it is not moving, and it cannot have gravitational potential energy or spring potential energy because the earth and the spring are not in the block system. The block-earth system has more gravitational potential energy when the block is at a greater height, and the block-earth system cannot have spring potential energy because the spring is not in the system. The block-spring system has zero spring potential energy at the initial time because the spring is not compressed, and it has some spring potential energy when the spring is compressed. The block-spring system cannot have gravitational potential energy because the earth is not in the system.

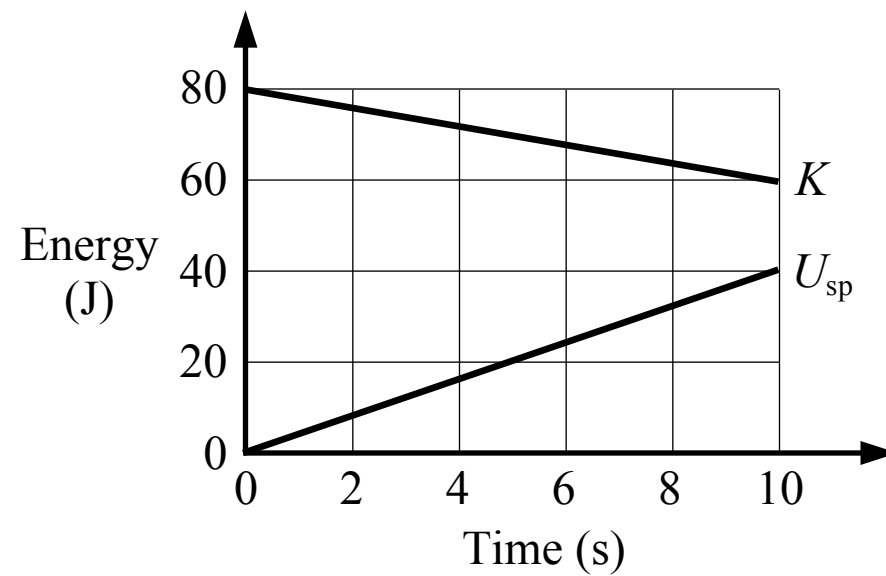

5. A graph of the energy in a system, which only has kinetic energy and spring potential energy, is shown in the figure above. Which of the following is true about this system?

- (A) There are no external forces acting on the system
- (B) There must be at least one external force acting on the system
- (C) There must be a friction force acting on the system
- (D) It cannot be determined if there are any external forces acting on the system

(A) Incorrect

(B) Correct

The total energy in the system increases over time from 80 J to 100 J so there must be a net external force doing work on the system. If there is a net external force there must be at least one external force.

(C) Incorrect

There must be a net external force acting on the system but it does not have to be a friction force.

(D) Incorrect

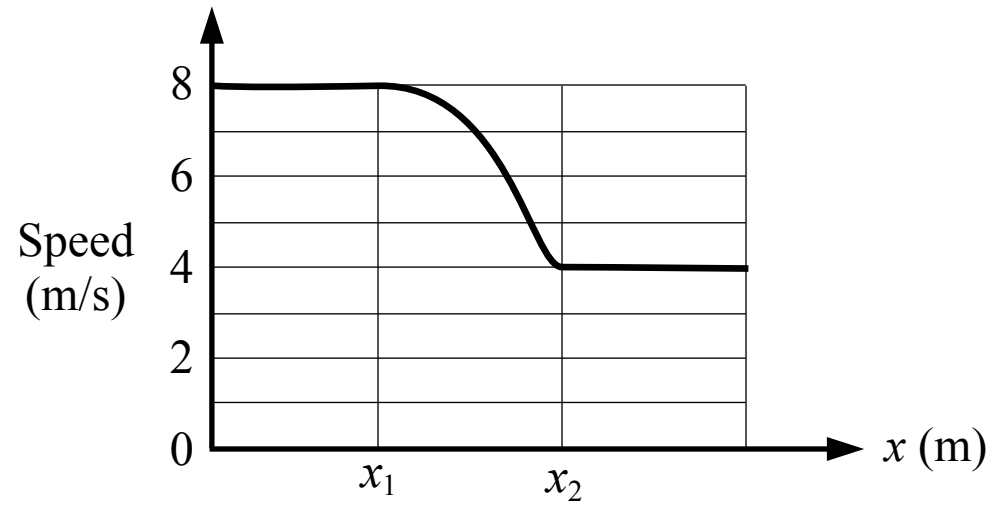
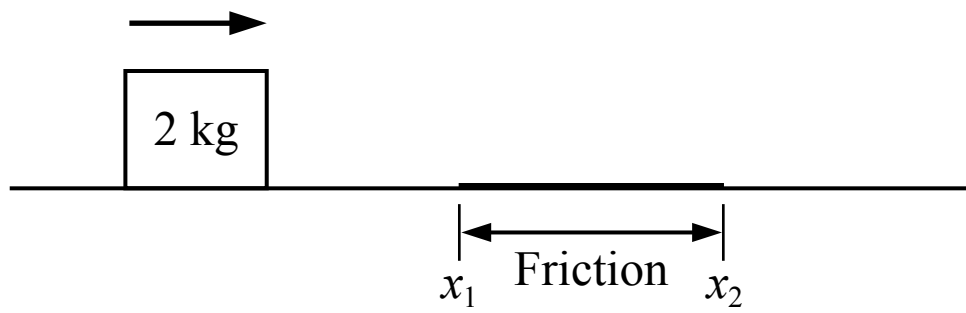

6. A block is sliding across a surface with negligible friction except for the length of surface between x_1 and x_2 . A graph of the block's motion is shown in the figure above. The work done on the block by friction is most nearly

- (A) -48 J
- (B) -16 J
- (C) -64 J
- (D) Cannot be determined

A Correct

The work done on the block by friction is equal to the change in the kinetic energy of the block as it slides across the length of surface with friction.

$$W = \Delta E = \Delta K = \frac{1}{2} m v_f^2 - \frac{1}{2} m v_i^2 = \frac{1}{2} (2 \text{ kg})(4 \text{ m/s})^2 - \frac{1}{2} (2 \text{ kg})(8 \text{ m/s})^2 = -48 \text{ J}$$

B Incorrect

This answer is the negative of the kinetic energy of the block after x_2 .

C Incorrect

This answer is the negative of the initial kinetic energy of the block.

D Incorrect

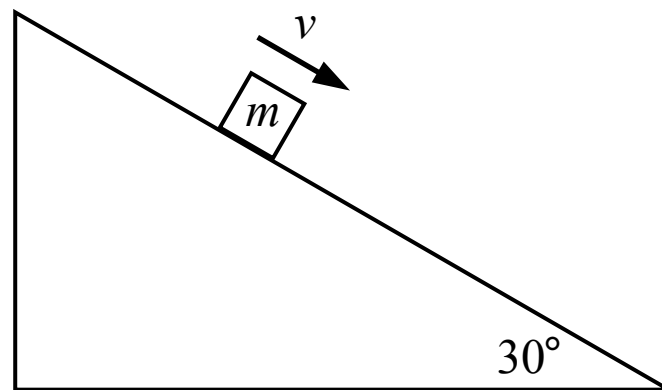

7. A block slides down an incline with a constant speed as shown in the figure above. The friction between the incline and the block is not negligible. Which of the following statements is true about the work done on the block?

- (A) The magnitude of the work done by gravity is equal to the magnitude of the work done by friction
- (B) The magnitude of the work done by friction is equal to the magnitude of the work done by the normal force
- (C) The magnitude of the work done by gravity is greater than the magnitude of the work done by friction
- (D) The magnitude of the work done by gravity is equal to the magnitude of the work done by the normal force

A Correct

The block moves at a constant speed so the acceleration and the net force on the block are zero (Newton's 1st law). The component of the weight force on the block that acts parallel to the incline must be equal to the friction force on the block (which acts in the opposite direction) and each force is applied over the same distance. The work done by a force is the component of the force in the direction of the motion multiplied by the distance the object moves, so the magnitudes of the work done by gravity and friction are equal:

$$W = F_{\parallel} d \quad \Sigma F_{\parallel} = F_{g_{\parallel}} - f_k = 0 \quad F_{g_{\parallel}} = f_k$$

We can also say the net work done on the block is equal to the change in the kinetic energy of the block. The block has a constant speed so the kinetic energy is constant and the net work done on the block is zero. The only two forces doing work on the block are gravity (which does positive work) and friction (which does negative work) so the work done by each force must have the same magnitude:

$$\Sigma W = \Delta K = 0 \quad W_g - W_f = 0 \quad W_g = W_f$$

B Incorrect

The work done by the normal force is zero because the force is perpendicular to the motion of the block.

C Incorrect

D Incorrect

The work done by the normal force is zero because the force is perpendicular to the motion of the block.

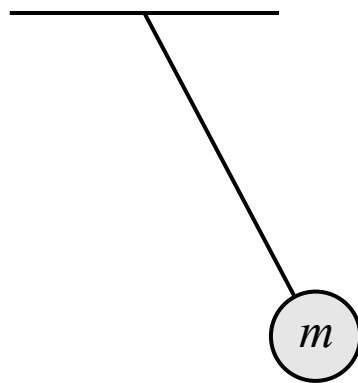

8. A pendulum consists of a sphere of mass m attached to a string with negligible mass. As the pendulum swings back and forth, which of the following statements is true?

- (A) The total kinetic energy of the sphere-earth system is constant
- (B) The total energy of the sphere-earth system is constant
- (C) The total gravitational potential energy of the sphere-earth system is constant
- (D) All of the above

(A) Incorrect

(B) Correct

The total energy of the sphere-earth system is conserved but the kinetic energy and gravitational potential energy are transformed back and forth as the sphere moves, so the amount of kinetic energy and gravitational potential energy is not constant. The kinetic energy depends on the speed of the sphere and the gravitational potential energy depends on the height of the sphere.

(C) Incorrect

(D) Incorrect

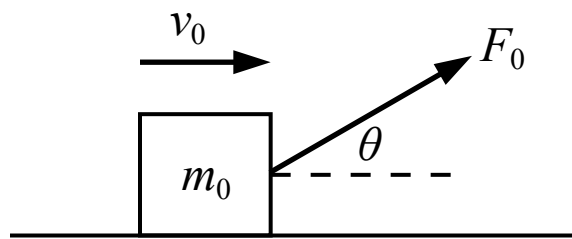

9. A block is sliding on a surface with negligible friction with a speed of v_0 when a force is applied to the block as shown in the figure above. When the block has moved a distance of d_0 it has kinetic energy K_0 . If the motion was repeated with a greater value of θ and no other changes, the kinetic energy of the block after moving a distance of d_0 would be

- (A) less than K_0
 (B) greater than K_0
 (C) equal to K_0
 (D) Cannot be determined

A Correct

The change in the kinetic energy of the block is equal to the work done by the applied force, which is equal to the horizontal component of the force multiplied by the distance that the block moves. If the angle is increased then the horizontal component of the applied force decreases and the work done (and the change in kinetic energy) is less than before.

$$W = \Delta E = \Delta K \quad F_0 \cos(\theta) d_0 = \Delta K$$

(B) Incorrect

(C) Incorrect

(D) Incorrect

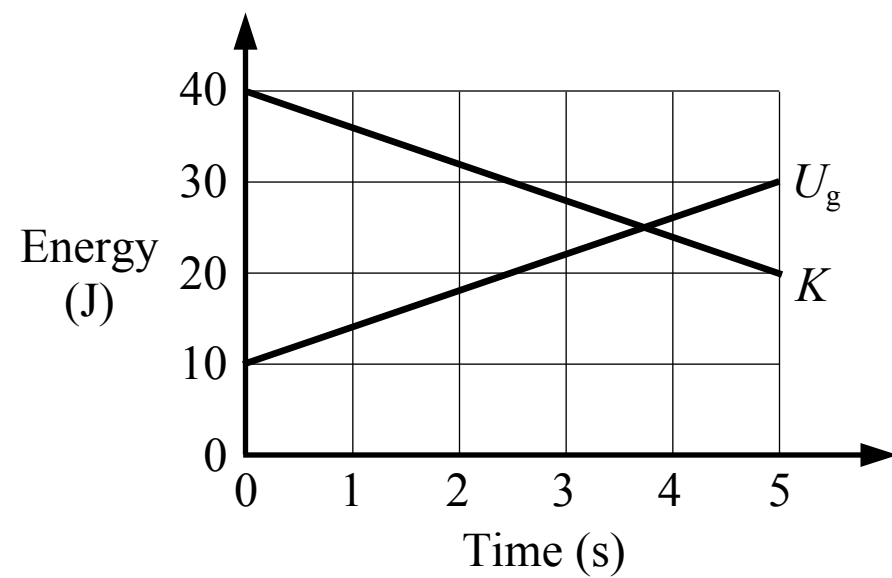

10. A graph of the energy in a system, which only has kinetic energy and gravitational potential energy, is shown in the figure above. Which of the following statements is true about this system from 0 s to 5 s?

- (A) 20 J of work is done on the system
- (B) 30 J of work is done on the system
- (C) 50 J of work is done on the system
- (D) No work is done on the system

A Incorrect

B Incorrect

C Incorrect

D **Correct**

The total amount of energy in the system remains constant (50 J) so no work is done on the system.

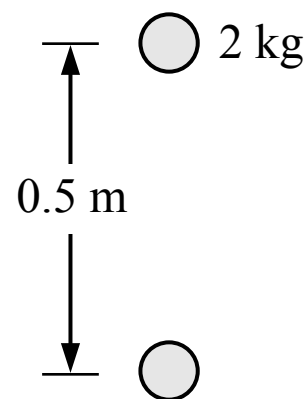

11. A person is holding a ball with a mass of 2 kg in the air at rest. They lower the ball a distance of 0.5 m at a constant speed and bring it to rest again at the lower height. Which of the following is true about the ball system between the initial and final heights?

- (A) The person does positive work on the system
- (B) The total energy of the system does not change
- (C) Gravity does zero work on the system
- (D) The total energy of the system decreases

(A) Incorrect

(B) Correct

The system is defined as only the ball and does not include the earth so the system can only have kinetic energy and it cannot have gravitational potential energy. The force from the person does negative work on the ball system (because the force from the person and the displacement are in opposite directions) and gravity does positive work on the ball system. The total amount of work done is zero and the change in kinetic energy is zero (the ball starts and ends at rest).

(C) Incorrect

(D) Incorrect

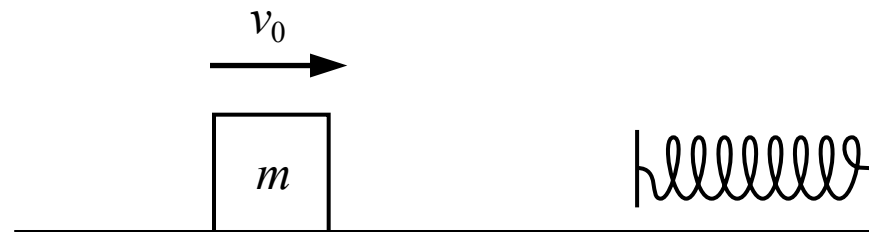

12. A block is sliding across a surface where the friction is not negligible. The block has an initial speed of v_0 at time t_0 . The block then collides with a spring and momentarily comes to a stop at time t_1 . Which of the following is true about the block-spring system from time t_0 to time t_1 ?
- (A) The spring does positive work on the system
 - (B) The total energy of the system is constant
 - (C) The spring does negative work on the system
 - (D) The total energy of the system decreases

A Incorrect

B Incorrect

C Incorrect

D **Correct**

The system is defined as the block and the spring so the forces between the block and the spring are internal and do not do work on the system (they only transform the kinetic energy into spring potential energy). The friction force acting on the block is an external force that does negative work on the system and some of the kinetic energy in the system is lost to the environment as heat energy, so the total energy of the block-spring system decreases.