

ROTATIONAL MOTION

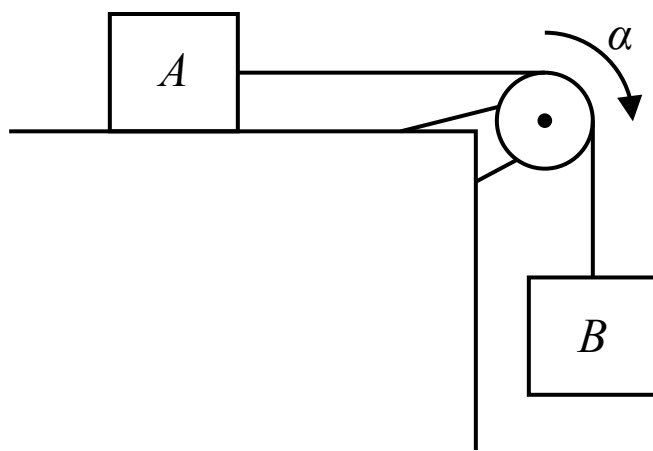

1. Two blocks are connected by a string that passes over a pulley as shown in the figure above. The blocks are released from rest, block B falls and the pulley experiences an angular acceleration. Which of the following graphs could represent the magnitude of the angular displacement of the pulley over time?

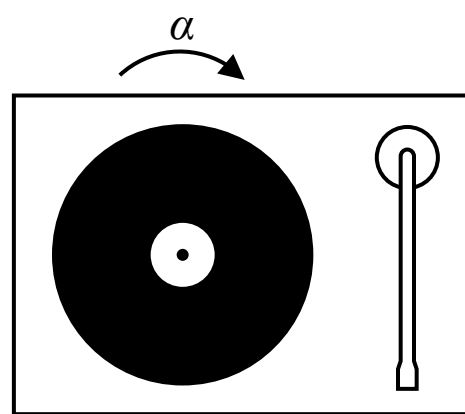
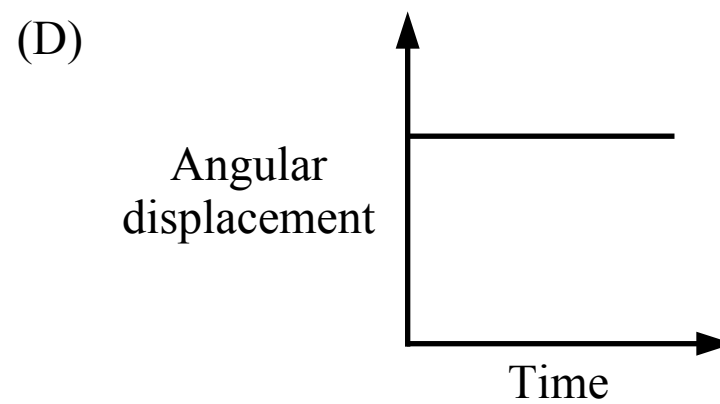
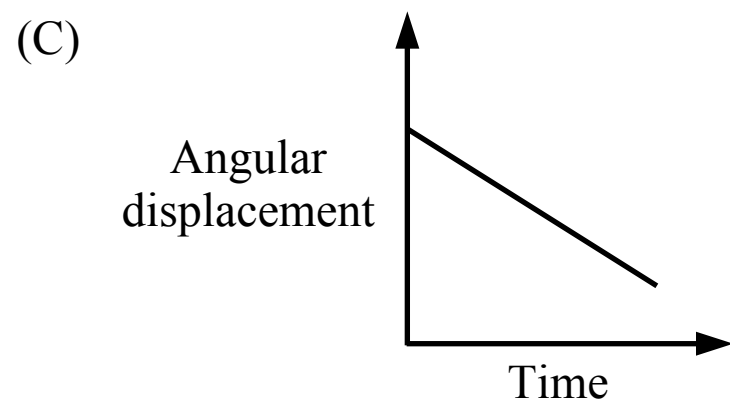
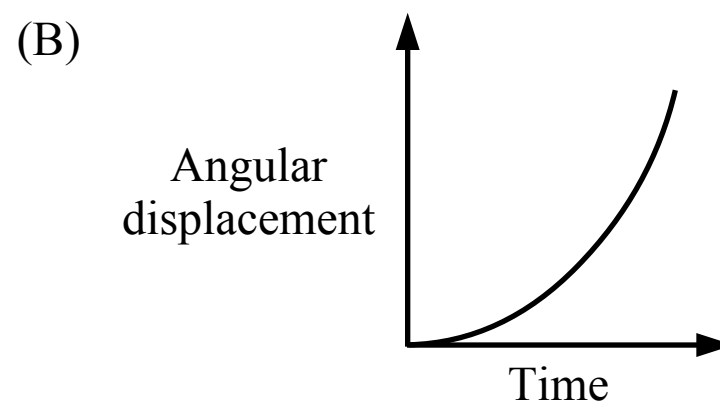
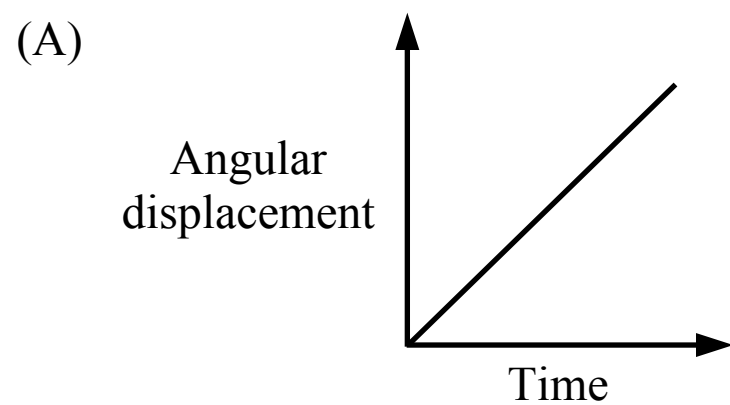

2. A vinyl record begins at rest and then experiences an angular acceleration of α . What is the angular displacement of the record after a period of 3 seconds?

- (A) 6α
- (B) 9α
- (C) 3α
- (D) $9\alpha/2$

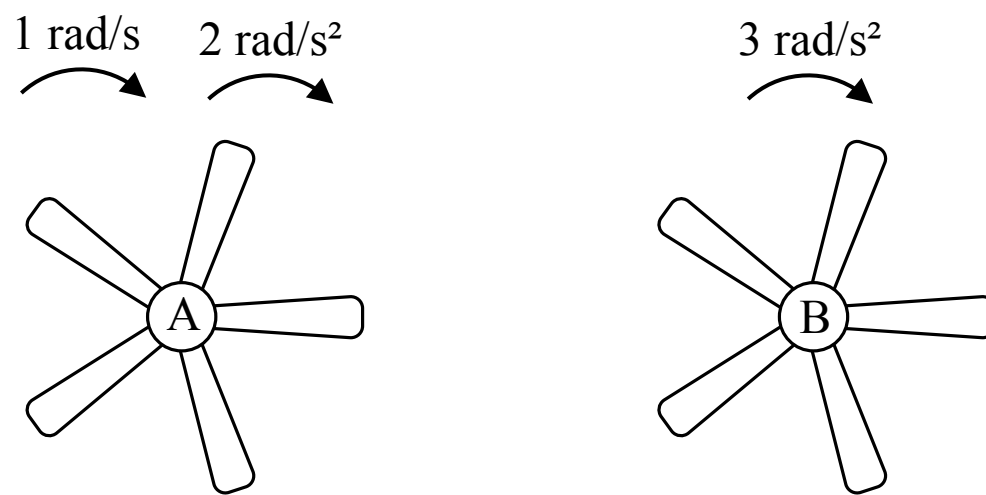

3. Two ceiling fans are shown in the figure above. At time t_0 , fan A is spinning at 1 rad/s and begins accelerating at 2 rad/s^2 , while fan B starts from rest and accelerates at 3 rad/s^2 . What is the relationship between the angular speed of the fans after a period of 5 seconds?

- (A) $\omega_A < \omega_B$
 (B) $\omega_A > \omega_B$
 (C) $\omega_A = \omega_B$
 (D) Cannot be determined

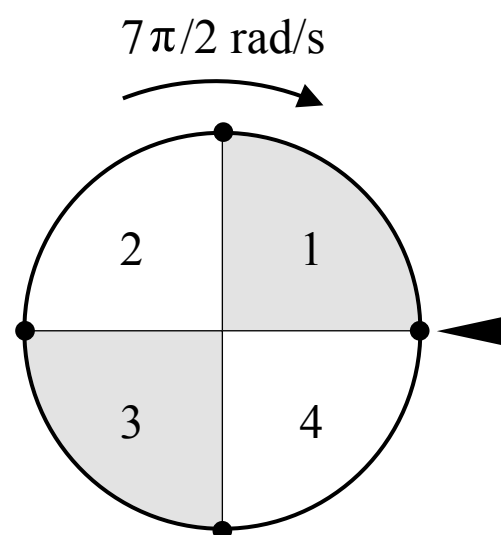

4. A wheel is divided into 4 equal sections as shown in the figure above. The wheel is given a spin and released so that the initial angular speed of the wheel is $7\pi/2 \text{ rad/s}$ when the wheel is in the orientation shown above. The wheel slows down at a rate of $-\pi/2 \text{ rad/s}^2$. What numbered section is the arrow on the right pointing to when the wheel stops?

- (A) 1
 (B) 2
 (C) 3
 (D) 4

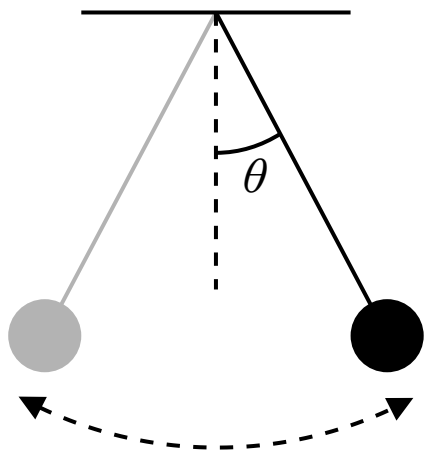

Note: Figure not drawn to scale

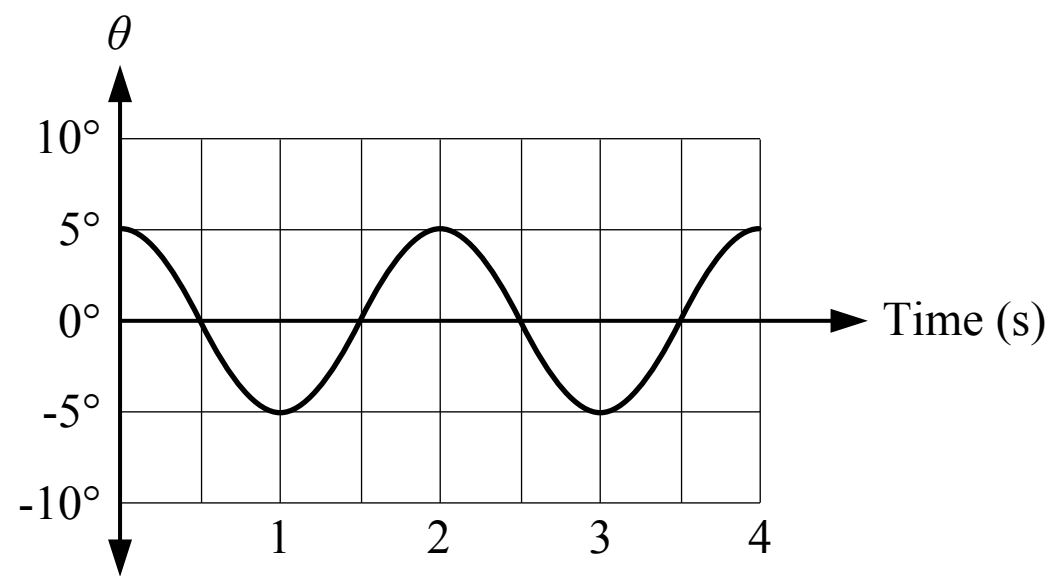

5. A graph of the motion of a pendulum is shown in the figure above. The angle of the pendulum is measured relative to the vertical. Which of the following is true about the motion of the pendulum?
- (A) The angular velocity of the pendulum at 1.5 seconds is zero
 - (B) The angular velocity of the pendulum at 3 seconds is zero
 - (C) The angular velocity of the pendulum is never zero
 - (D) The angular velocity of the pendulum is always zero

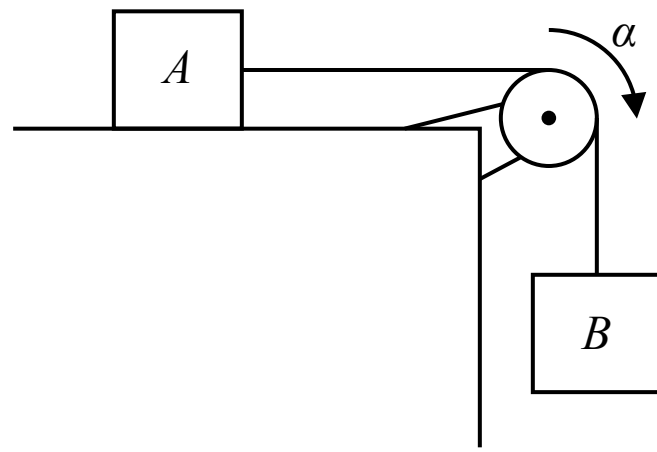

1. Two blocks are connected by a string that passes over a pulley as shown in the figure above. The blocks are released from rest, block B falls and the pulley experiences an angular acceleration. Which of the following graphs could represent the magnitude of the angular displacement of the pulley over time?

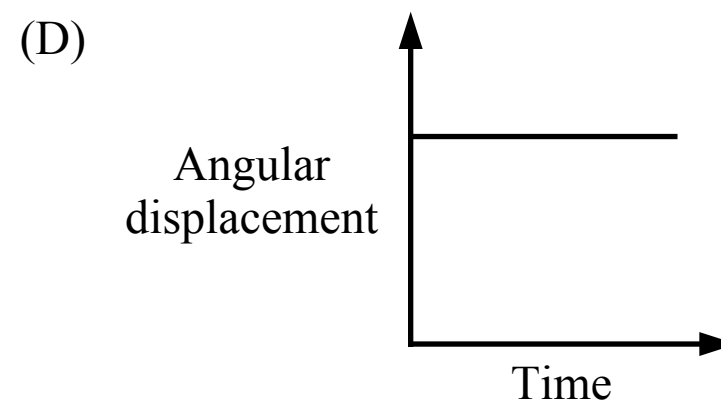
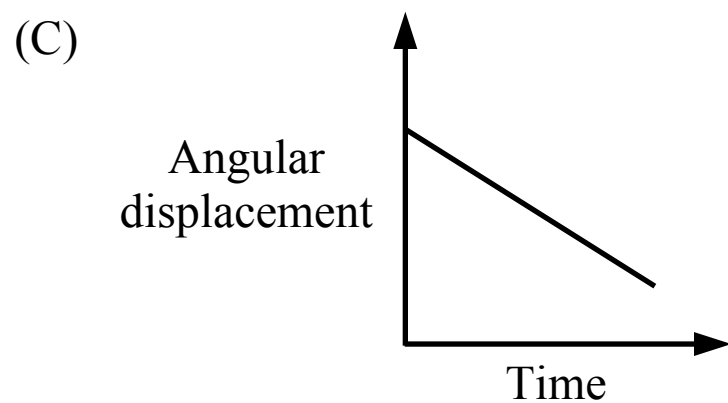
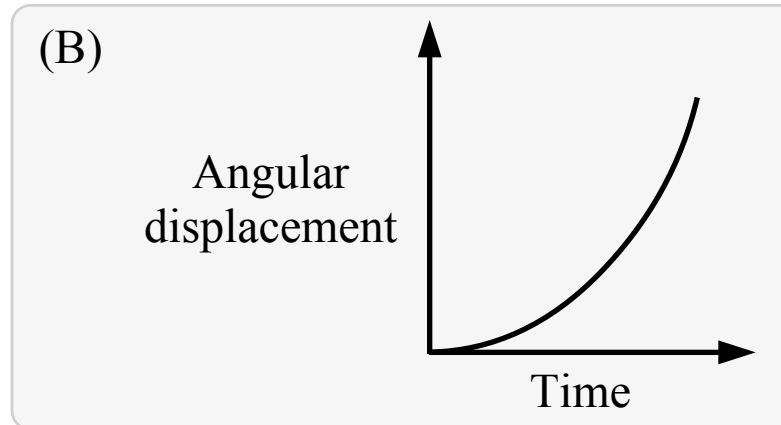
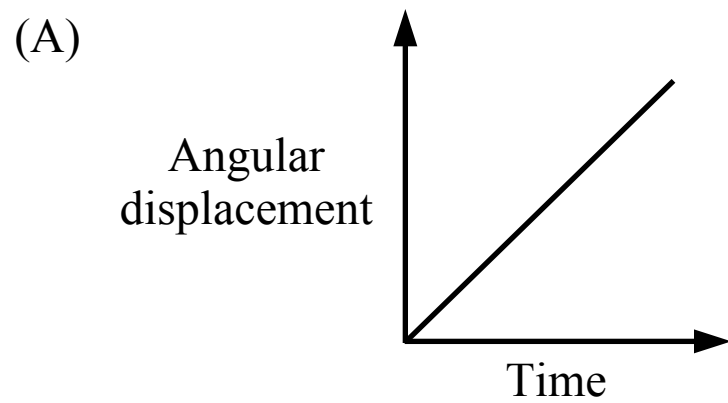

- (A) Incorrect
This graph is a straight line with a non-zero slope which represents a constant angular velocity with zero acceleration.
- (B) Correct**
The pulley experiences an angular acceleration so the angular position-time graph and the angular displacement-time graph is a curved line. The slope of the angular displacement-time graph is the angular velocity, which is changing because there is an angular acceleration.
- (C) Incorrect
This graph is a straight line with a non-zero slope which represents a constant angular velocity with zero acceleration.
- (D) Incorrect
This graph is a straight line with zero slope which represents an angular velocity of zero.

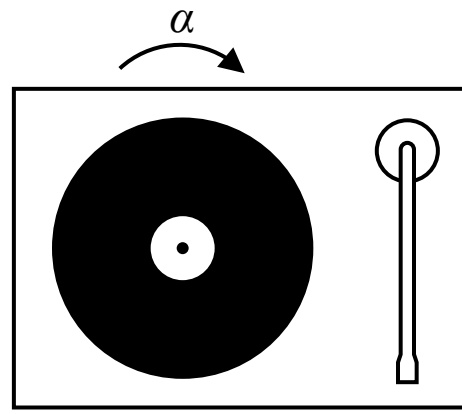

2. A vinyl record begins at rest and then experiences an angular acceleration of α . What is the angular displacement of the record after a period of 3 seconds?

- (A) 6α
- (B) 9α
- (C) 3α
- (D) $9\alpha/2$

A Incorrect

B Incorrect

C Incorrect

D **Correct**

The angular displacement can be found using the kinematic equation below.

$$\Delta\theta = \omega_0 t + \frac{1}{2}\alpha t^2 = (0 \text{ rad/s})(3 \text{ s}) + \frac{1}{2}\alpha(3)^2 = 9\alpha/2$$

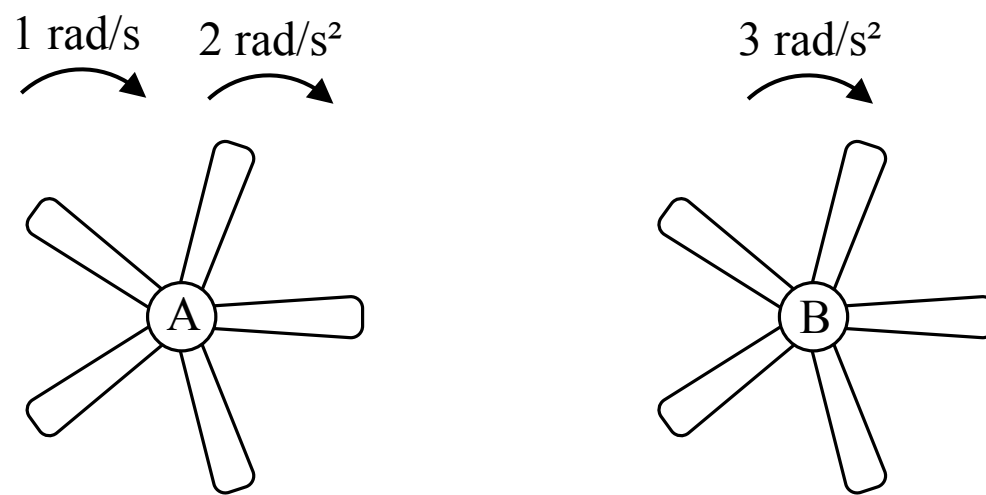

3. Two ceiling fans are shown in the figure above. At time t_0 , fan A is spinning at 1 rad/s and begins accelerating at 2 rad/s², while fan B starts from rest and accelerates at 3 rad/s². What is the relationship between the angular speed of the fans after a period of 5 seconds?

- (A) $\omega_A < \omega_B$
 (B) $\omega_A > \omega_B$
 (C) $\omega_A = \omega_B$
 (D) Cannot be determined

A Correct

Fan A: $\omega = \omega_0 + \alpha t = (1 \text{ rad/s}) + (2 \text{ rad/s}^2)(5 \text{ s}) = 11 \text{ rad/s}$

Fan B: $\omega = \omega_0 + \alpha t = (0 \text{ rad/s}) + (3 \text{ rad/s}^2)(5 \text{ s}) = 15 \text{ rad/s}$

(B) Incorrect

(C) Incorrect

(D) Incorrect

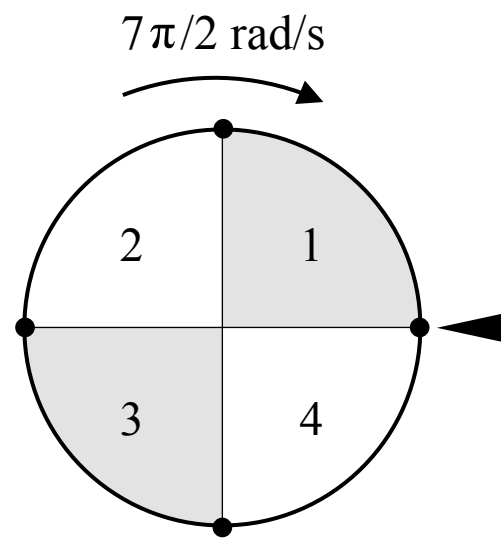

4. A wheel is divided into 4 equal sections as shown in the figure above. The wheel is given a spin and released so that the initial angular speed of the wheel is $7\pi/2$ rad/s when the wheel is in the orientation shown above. The wheel slows down at a rate of $-\pi/2$ rad/s². What numbered section is the arrow on the right pointing to when the wheel stops?

- (A) 1
 (B) 2
 (C) 3
 (D) 4

A Correct

The angular displacement of the wheel can be found using the kinematic equation below. The wheel turns 6 full revolutions and then 1/8 of a revolution so it ends at the middle of section 1.

$$\omega^2 = \omega_0^2 + 2\alpha\Delta\theta \quad (0 \text{ rad/s})^2 = (7\pi/2 \text{ rad/s})^2 + 2(-\pi/2 \text{ rad/s}^2)\Delta\theta \quad \Delta\theta = 49\pi/4 \text{ rad}$$

$$\Delta\theta = \frac{49\pi/4 \text{ rad}}{2\pi \text{ rad}} \times \frac{1 \text{ rev}}{2\pi \text{ rad}} = 6 \frac{1}{8} \text{ rev}$$

- (B) Incorrect
 (C) Incorrect
 (D) Incorrect

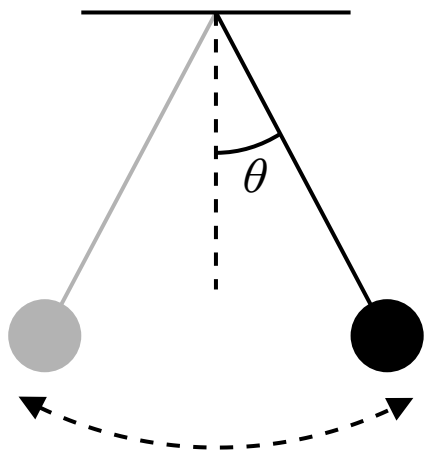

Note: Figure not drawn to scale

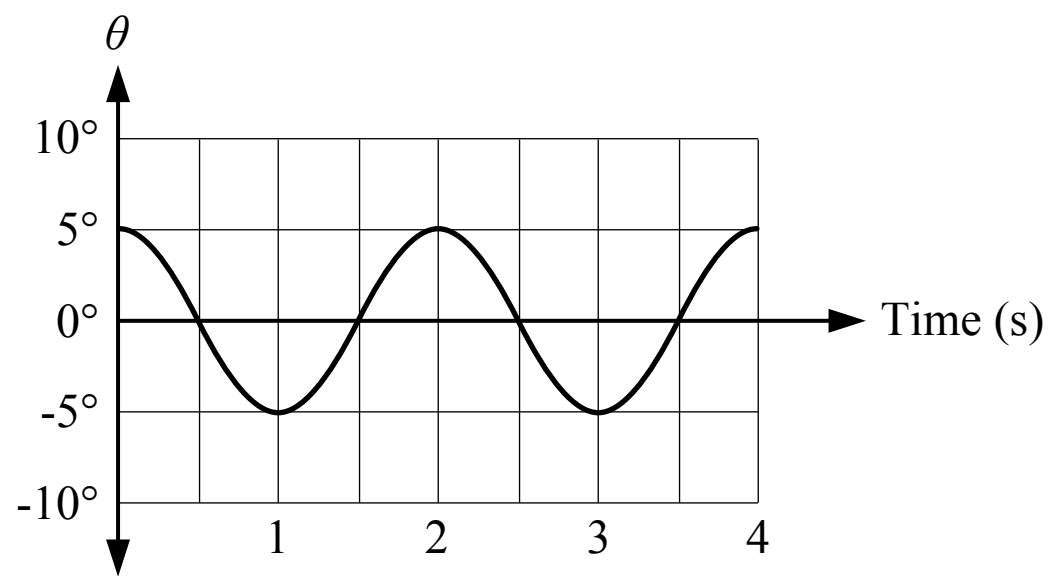

5. A graph of the motion of a pendulum is shown in the figure above. The angle of the pendulum is measured relative to the vertical. Which of the following is true about the motion of the pendulum?

- (A) The angular velocity of the pendulum at 1.5 seconds is zero
- (B) The angular velocity of the pendulum at 3 seconds is zero
- (C) The angular velocity of the pendulum is never zero
- (D) The angular velocity of the pendulum is always zero

(A) Incorrect

The angular position is zero at 1.5 seconds but the angular velocity (the slope) is not zero.

(B) **Correct**

The graph is an angular position-time graph so the slope of the graph is the angular velocity. The slope of the graph and the angular velocity are zero at 3 seconds.

(C) Incorrect

The angular velocity (the slope) is zero at 0, 1, 2, 3 and 4 seconds.

(D) Incorrect

The angular velocity (the slope) is not always zero.