



Installation, Operation, and Maintenance

Air-Cooled Scroll Chillers

Model CGAM

20 to 130 Tons — Made in USA



⚠ SAFETY WARNING

Only qualified personnel should install and service the equipment. The installation, starting up, and servicing of heating, ventilating, and air-conditioning equipment can be hazardous and requires specific knowledge and training. Improperly installed, adjusted or altered equipment by an unqualified person could result in death or serious injury. When working on the equipment, observe all precautions in the literature and on the tags, stickers, and labels that are attached to the equipment.



Introduction

Read this manual thoroughly before operating or servicing this unit.

Warnings, Cautions, and Notices

Safety advisories appear throughout this manual as required. Your personal safety and the proper operation of this machine depend upon the strict observance of these precautions.

The three types of advisories are defined as follows:

⚠ WARNING Indicates a potentially hazardous situation which, if not avoided, could result in death or serious injury.

⚠ CAUTION Indicates a potentially hazardous situation which, if not avoided, could result in minor or moderate injury. It could also be used to alert against unsafe practices.

NOTICE Indicates a situation that could result in equipment or property-damage only accidents.

Important Environmental Concerns

Scientific research has shown that certain man-made chemicals can affect the earth's naturally occurring stratospheric ozone layer when released to the atmosphere. In particular, several of the identified chemicals that may affect the ozone layer are refrigerants that contain Chlorine, Fluorine and Carbon (CFCs) and those containing Hydrogen, Chlorine, Fluorine and Carbon (HCFCs). Not all refrigerants containing these compounds have the same potential impact to the environment. Trane advocates the responsible handling of all refrigerants-including industry replacements for CFCs and HCFCs such as saturated or unsaturated HFCs and HCFCs.

Important Responsible Refrigerant Practices

Trane believes that responsible refrigerant practices are important to the environment, our customers, and the air conditioning industry. All technicians who handle refrigerants must be certified according to local rules. For the USA, the Federal Clean Air Act (Section 608) sets forth the requirements for handling, reclaiming, recovering and recycling of certain refrigerants and the equipment that is used in these service procedures. In addition, some states or municipalities may have additional requirements that must also be adhered to for responsible management of refrigerants. Know the applicable laws and follow them.

⚠ WARNING

Proper Field Wiring and Grounding Required!

Failure to follow code could result in death or serious injury. All field wiring **MUST** be performed by qualified personnel. Improperly installed and grounded field wiring poses **FIRE** and **ELECTROCUTION** hazards. To avoid these hazards, you **MUST** follow requirements for field wiring installation and grounding as described in NEC and your local/state electrical codes.

⚠ WARNING

Personal Protective Equipment (PPE) Required!

Failure to wear proper PPE for the job being undertaken could result in death or serious injury. Technicians, in order to protect themselves from potential electrical, mechanical, and chemical hazards, **MUST** follow precautions in this manual and on the tags, stickers, and labels, as well as the instructions below:

- Before installing/servicing this unit, technicians **MUST** put on all PPE required for the work being undertaken (Examples; cut resistant gloves/sleeves, butyl gloves, safety glasses, hard hat/bump cap, fall protection, electrical PPE and arc flash clothing). **ALWAYS** refer to appropriate Material Safety Data Sheets (MSDS)/Safety Data Sheets (SDS) and OSHA guidelines for proper PPE.
- When working with or around hazardous chemicals, **ALWAYS** refer to the appropriate MSDS/SDS and OSHA/GHS (Global Harmonized System of Classification and Labelling of Chemicals) guidelines for information on allowable personal exposure levels, proper respiratory protection and handling instructions.
- If there is a risk of energized electrical contact, arc, or flash, technicians **MUST** put on all PPE in accordance with OSHA, NFPA 70E, or other country-specific requirements for arc flash protection, **PRIOR** to servicing the unit. **NEVER PERFORM ANY SWITCHING, DISCONNECTING, OR VOLTAGE TESTING WITHOUT PROPER ELECTRICAL PPE AND ARC FLASH CLOTHING. ENSURE ELECTRICAL METERS AND EQUIPMENT ARE PROPERLY RATED FOR INTENDED VOLTAGE.**

⚠ WARNING**Follow EHS Policies!**

Failure to follow instructions below could result in death or serious injury.

- All Ingersoll Rand personnel must follow Ingersoll Rand Environmental, Health and Safety (EHS) policies when performing work such as hot work, electrical, fall protection, lockout/tagout, refrigerant handling, etc. All policies can be found on the [BOS site](#). Where local regulations are more stringent than these policies, those regulations supersede these policies.
- Non-Ingersoll Rand personnel should always follow local regulations.

⚠ WARNING**Hazardous Service Procedures!**

Failure to follow all precautions in this manual and on the tags, stickers, and labels could result in death or serious injury.

Technicians, in order to protect themselves from potential electrical, mechanical, and chemical hazards, **MUST** follow precautions in this manual and on the tags, stickers, and labels, as well as the following instructions: Unless specified otherwise, disconnect all electrical power including remote disconnect and discharge all energy storing devices such as capacitors before servicing. Follow proper lockout/tagout procedures to ensure the power can not be inadvertently energized. When necessary to work with live electrical components, have a qualified licensed electrician or other individual who has been trained in handling live electrical components perform these tasks.

Factory Warranty Information

Compliance with the following is required to preserve the factory warranty:

All Unit Installations

Startup **MUST** be performed by Trane, or an authorized agent of Trane, to **VALIDATE** this WARRANTY. Contractor must provide a two-week startup notification to Trane (or an agent of Trane specifically authorized to perform startup).

Copyright

This document and the information in it are the property of Trane, and may not be used or reproduced in whole or in part without written permission. Trane reserves the right to revise this publication at any time, and to make changes to its content without obligation to notify any person of such revision or change.

Trademarks

All trademarks referenced in this document are the trademarks of their respective owners.

Revision History

- Updated to adjust evaporator minimum flow rates in general data and pressure drop curves.
- Added rigging/lifting notice.
- Updated elastomeric isolator selection tables to correct errors.
- Updated low evaporator refrigerant cutout percent glycol recommendations tables.



Table of Contents

Model Number Descriptions	7	Drainage	65
Nameplates	7	Evaporator Piping Components	65
Unit Nameplate	7	Entering Chilled Water Piping	66
Compressor Nameplate	7	Leaving Chilled Water Piping	66
Model Number Coding System	7	Water Strainer	66
Model Number Descriptions	8	Flow Switch	66
Unit Model Number Description	8	Evaporator Label	67
Compressor Model Number Description	9	Pressure Drop Curves	68
General Information	10	Ambient Freeze Avoidance	69
Unit Description	10	Low Evap Refrigerant Cutout/ Percent Glycol Recommendations	69
Accessory/Options Information	12	Performance Adjustment Factors	73
General Data	14	Partial Heat Recovery	74
Pre-Installation	24	Partial Heat Recovery Piping	74
Inspection Checklist	24	Partial Heat Recovery Freeze Avoidance	75
Unit Storage	24	Partial Heat Recovery Pressure Drop Curves	76
Installation Requirements	24	Dual High Head Pump Package	77
Dimensions and Weights	25	Pressure Drop Information - Units with Optional Pump Package	78
Service Clearances	25	Pump Package Requirements	81
Mounting Locations	26	Expansion Tank - Maximum Loop Volume	82
Unit without Wind Load Rating	26	Installation - Electrical	84
Units with Wind Load Rating	29	General Recommendations	84
Weights	31	Installer-Supplied Components	84
Base Units	31	Power Supply Wiring	85
Option Weights	36	Control Power Supply	85
Installation - Mechanical	38	Heater Power Supply	85
Location Requirements	38	Partial Heat Recovery Power Supply	86
Sound Considerations	38	Water Pump Power Supply	86
Wind Load Considerations	38	Interconnecting Wiring	86
Foundation	38	Chilled Water Flow (Pump) Interlock	86
Clearances	38	Chilled Water Pump Control	86
Rigging	38	Chilled Water Pump Control — Field Supplied Dual Pumps	87
Lifting Procedure	38	Chilled Water Pump Control — Optional Pump Package	87
Center of Gravity	40	Alarm and Status Relay Outputs (Programmable Relays)	88
Unit Isolation and Leveling	45		
General	45		
Isolator Options	45		
Isolator Selection and Placement	48		
Evaporator Piping	65		

Low Voltage Wiring	88	Lockout Screen	111
Emergency Stop	88	Reports	111
External Auto/Stop	89	Power Up and Self Tests	112
Ice Building Option	89	TechView	112
External Chilled Water Setpoint (ECWS) Option	89	Unit View	114
External Demand Limit Setpoint (EDLS) Option	90	Diagnostics View	119
ECWS and EDLS Analog Input Signal Wiring Details	90	Configuration View	119
Chilled Water Reset (CWR)	90	Software View	121
Percent Capacity Output Option	91	Binding View	122
Communications Interface Options	91	Pre-Start Checkout	123
Tracer Communications Interface	91	Start-Up and Shutdown	124
LonTalk Communications Interface for Chill- ers (LCI-C)	92	Start-Up	124
BACnet Interface (BCI-C)	92	Seasonal Unit Start-Up Procedure	124
CGAM Operating Principles	93	Seasonal Unit Shutdown	124
General	93	Sequence of Operation	125
Base Units	94	Software Operation Overview	125
Pump Package Components - Optional	96	Power Up	126
Buffer Tank Components - Optional	100	Power Up to Starting	126
Partial Heat Recovery Components	100	Stopped to Starting	127
Refrigerant Cycle	102	Normal Shutdown to Stopped	127
Oil System Operation (CGAM)	102	Maintenance	128
Sensor Requirements	102	Recommended Maintenance	128
Controls Interface	103	Weekly	128
CH530 Communications Overview	103	Monthly	128
DynaView Interface	103	Annual	128
Display Screens	104	Refrigerant and Oil Charge Management	129
Basic Screen Format	104	Lubrication System	129
Auto, Stop/Immediate Stop	104	Oil Level	129
Diagnostic Annunciation	104	Oil Testing	129
Manual Override Exists	105	Condenser Maintenance	130
Main Screen	105	Microchannel Condensers	130
Chiller Operating Mode	105	Round Tube Plate Fin Condensers	130
Active Chilled Water Setpoint	105	Evaporator Maintenance	131
Other Active Setpoints	106	Water Strainer Maintenance	131
Password-Protected Settings	106	Pump Package Maintenance	132
Settings Screen	106	Rust Prevention	132
Local Time of Day Schedule Screen	108	Diagnostics	133
		Main Processor Diagnostic	134
		Sensor Failure Diagnostics	140



Table of Contents

Communication Diagnostics	141
Main Processor- Boot Messages and Diagnostics	144
Unit Wiring	145
Log and Check Sheet	146



Model Number Descriptions

Nameplates

The CGAM unit nameplates are applied to the exterior surface of the control panel door for 20-70 Ton sizes. The 80-120 Ton sizes have a nameplate on a support beam to the right side of the starter panel.

A compressor nameplate is located on each compressor. See [Figure 1](#).

Unit Nameplate

The unit nameplate provides the following information:

- Unit model and size descriptor.
- Unit serial number.
- Identifies unit electrical requirements.
- Lists correct operating charges of R-410A and refrigerant oil.
- Lists unit design pressures.
- Identifies installation, operation and maintenance and service data literature.
- Lists drawing numbers for unit wiring diagrams.

Compressor Nameplate

The compressor nameplate provides the following information:

- Compressor model number.
- Compressor serial number.
- Compressor electrical characteristics.
- Utilization Range.
- Recommended refrigerant.

Model Number Coding System

The model numbers for the unit and the compressors are comprised of numbers and letter which represent features of the equipment.

See [“Unit Model Number Description,” p. 8](#) and [“Compressor Model Number Description,” p. 9](#) for details.

Each position, or group of positions, in a number or letter is used to represent a feature. For example, from the chart, we can determine that the letter “F” in digit 8 of the unit model number indicates unit voltage is 460/60/3.

Figure 1. Unit and compressor nameplates

				FOR OUTDOOR USE				SERIAL NUMBER			
MODEL NUMBER											
RATED VOLTAGE/HZ/PH				MIN CKT AMPACITY (A)				MAX FUSE/BREAKER (A)			
VOLT UTILIZATION RANGE				SHORT-CIRCUIT CURRENT RATING (A)				RATED VOLTAGE/HZ/PH			
COMPR MTR 1A				COMPR MTR 2A				CKT 3 FREEZE PROTECTION HEATERS			
COMPR MTR 1B				COMPR MTR 2B				WATTS			
COMPR MTR 1C				COMPR MTR 2C				CKT 4 BUFFER TANK HEATER			
FIXED SPEED FAN MOTORS				REFRIGERANT				CHARGED			
2 SPEED FAN MOTORS				TYPE/NUMBER				RFGT CHARGE			
VFD CONTROLLED FAN MOTORS				OIL CHARGE				TYPE/NUMBER			
* PUMP MOTORS				CKT 1 (LBS)				CKT 1 (GAL)			
* EXCLUSIVELY INTERLOCKED				CKT 2 (LBS)				CKT 2 (GAL)			
WIRING DIAGRAM BOOK				DESIGN PRESSURES (PSI)				HIGH SIDE			
INSTALLATION, OPERATION & MAINTENANCE MANUAL				LOW SIDE				LUBRICANT			
<small>MANUFACTURED UNDER ONE OR MORE OF THE FOLLOWING U.S. PATENTS/ CORRESPONDING FOREIGN PATENTS OWNED BY TRANE. 5,231,946 5,419,146 5,632,154 5,809,794 5,950,443 6,049,299 6,085,532 6,266,964 6,276,152 6,666,042 6,917,857 7,020,198 7,086,346 7,156,121 7,202,858 7,385,593</small>											
TRANE				MADE IN USA				X39003199010E			

CGAM Unit Nameplate

SCROLL COMPRESSOR	
MODEL: (ITEM B)	
TRANE PART NO: (ITEM A)	
SERIAL: ABCDDDDDD	
FIELD SERVICE PART NO: (ITEM C)	
THERMALLY PROTECTED	
VOLTAGE -1 (ITEM D)	
VOLTAGE -2 (ITEM E)	
MAX AMPS (ITEM F)	
LRA (ITEM G)	
LUBRICANT	POLYESTER OIL
USE TRANE OIL ONLY	OIL00079 OR OIL0063E
	VOL: (ITEM H)
REFRIGERANT: R410A	
MADE IN MEXICO XXXY	

CGAM Compressor Nameplate



Model Number Descriptions

Unit Model Number Description

Digits 1-4 – Chiller Model

CGAM= Air-Cooled Scroll Packaged Chiller

Digits 5-7 – Unit Nominal Ton

- 020 = 20 Tons
- 026 = 26 Tons
- 030 = 30 Tons
- 035 = 35 Tons
- 040 = 40 Tons
- 052 = 52 Tons
- 060 = 60 Tons
- 070 = 70 Tons
- 080 = 80 Tons
- 090 = 90 Tons
- 100 = 100 Tons
- 110 = 110 Tons
- 120 = 120 Tons
- 130 = 130 Tons

Digit 8 – Unit Voltage

- A = 208 Volt 60 Hz 3 Phase
- B = 230 Volt 60 Hz 3 Phase
- D = 380 Volt 60 Hz 3 Phase
- E = 400 Volt 50 Hz 3 Phase
- F = 460 Volt 60 Hz 3 Phase
- G = 575 Volt 60 Hz 3 Phase

Digit 9 – Manufacturing Plant

- 2 = Pueblo, USA

Digits 10-11 – Design Sequence

** = Factory/ABU Assigned

Digit 12 – Unit Type

- 2 = High Efficiency
- 3 = Extra Efficiency

Digit 13 – Agency Listing

- X = No Agency Listing
- A = UL Listed to U.S. and Canadian Safety Standard

Digit 14 – Pressure Vessel Code

- X = No Pressure Vessel Code

Digit 15 – Unit Application

- B = High Ambient (32-125°F/0-52°C)
- D = Wide Ambient (0-125°F/-18-52°C)
- J = Extreme Low Ambient – down to -20°F (-28.9°C)

Digit 16 – Refrigerant Isolation Valves

- 2 = Refrigerant Isolation Valves (Discharge Valve)

Digit 17 – Structural Options

- A = Standard Unit Structure
- B = Seismic to International Building Code (IBC)
- C = California Office of Statewide Health Planning and Development (OSHPD) Certification
- D = Wind Load for Florida Hurricane

Digit 18 – Freeze Protection (Factor-Installed Only)

- X = Without Freeze Protection
- 1 = With Freeze Protection (External T-Stat Control)

Digit 19 – Insulation

- A = Factory Insulation - All Cold Parts
- B = Insulation for High Humidity/Low Evap Temp

Digit 20 – Factory Charge

- 1 = Full Factory Refrigerant Charge (R-410A)
- 2 = Nitrogen Charge

Digit 21 – Evaporator Application

- A = Standard Cooling (40 to 65°F/4.4 to 18°C)
- B¹ = Low Temperature Process (10 to 40°F/-12.2 to 4.4°C)
- C¹ = Ice-Making - Hardwired Interface (20 to 65°F/-7 to 18°C)
- D¹ = Low Leaving Water (below 10°F/-12.2°C)

Digit 22 – Water Connections

- 1 = Grooved Pipe Connection

Digit 23 – Condenser Fin Material

- A = Lanced Aluminum Fins
- C = Non-Lanced Copper Fins
- D = Lanced Aluminum Fins w/ CompleteCoat™
- H = Microchannel Coils
- J = Microchannel Coils w/ CompleteCoat

Digit 24 – Condenser Heat Recovery

- X = No Heat Recovery
- 1¹ = Partial Heat Recovery with Fan Control

Note: Heat pump option is only available on units manufactured in Epinal.¹

Digit 25 – Not Used

- X

Digit 26 – Starter Type

- A = Across the Line Starter/ Direct on Line

Digit 27 – Incoming Power Line Connection

- 1 = Single Point Power Connection

Digit 28 – Power Line Connection Type

- A = Terminal Block
- C = Circuit Breaker
- D = Circuit Breaker with High Fault Rated Control Panel

Digit 29 – Enclosure Type

- 1 = Water Tight (per UL 1995 Standard)

Digit 30 – Unit Operator Interface

- A = Dyna-View/English

Digit 31 – Remote Interface (Digital Comm)

- X = No Remote Digital Communication
- 2 = LonTalk®/Tracer® Summit Interface
- 3 = Time of Day Scheduling
- 4 = BACNet® Interface

Digit 32 – External Chilled/Hot Water and Current Demand Limit Setpoint

- X = No External Chilled Water Setpoint
- A = External Chilled Water and Demand Limit Setpoint 4-20mA
- B = External Chilled Water and Demand Limit Setpoint 2-10Vdc

Digit 33 – Percent Capacity

- X = Without % Capacity
- 1 = With % Capacity

Digit 34 – Programmable Relays

- X = No Programmable Relays
- A = Programmable Relays

Digit 35 – Pump Type

- X = No Pumps and No Contactors
- 8 = Dual High Head Pump

Digit 36 – Pump Flow Control

- X = No Pump Control
- B = Pump Flow Controlled by Variable Speed Drive

Digit 37 – Buffer Tank

- X

Digit 38 – Short Circuit Rating

- X = No Short Circuit Rating
- A = Default A Short Circuit Rating
- B = High A Short Circuit Rating

¹ Units with this option selected will require a discharge temperature sensor.

Model Number Descriptions

Digit 39— Installation

Accessories

- X = No Installation Accessories
- 1 = Elastomeric Isolators
- 3 = Seismically Rated Isolators
- 5 = Elastomeric Pads

Digit 40— Water Strainer

- A = With Water Strainer Factory Installed

Digit 41— Sound Attenuator Package

- 3 = Super Quiet
- 5 = Comprehensive Acoustic Package

Digit 42— Appearance Options

- X = No Appearance Options
- A = Architectural Louvered Panels
- B = Half Louvers

Digit 43— Exterior Finish

- 1 = Standard Paint

Digit 44— Label, Literature Language

- B = Spanish and English
- D = English
- E = French and English

Digit 45— Phase Reversal Protection

- 1 = Phase Reversal Protection

Digit 46— Shipping Package

- X = No Skid (Standard)
- A = Unit Containerization Package

Digit 47— Performance Test Options

- X = No Performance Test
- 2 = Test with Report
- 3 = Witness Test with Report

Digit 48— Flow Switch Set Point

- C = Flow Switch Set Point 15
- F = Flow Switch Set Point 35
- H = Flow Switch Set Point 45
- L = Flow Switch Set Point 60

Digit 49— Not Used

- X

Digit 50— Specials

- X = None
- S = Special

Note: If a digit is not defined it may be held for future use.

Compressor Model Number Description

Digits 1-4— Compressor Model

- CSHD= Light Commercial
- CSHN= Commercial
- CSHL= Permanent Magnet

Digits 5-7— Capacity

- 125 = CSHD 10.5 ton
- 161 = CSHD 13.4 ton
- 184 = CSHD or CSHN 15 ton
- 250 = CSHN 20 ton
- 315 = CSHN 25 ton
- 374 = CSHN or CSHL 30 ton

Digit 8— Voltage

- J = 200-230/60/3
- K = 460/60/3 - 400/50/3
- F = 230/50/3
- D = 575/60/3
- X = 380/60/3

Digit 9— Unloading

- 0 = No Unloading

Digit 10— Design Sequence

- Factory Assigned

Digit 11— Protection Module Voltage

- 0 = Internal Line Break
- A = 115 VAC
- B = 230 VAC
- H = 24 VAC
- K = 115/230 VAC

Digit 12— Basic Compressor Variation

- M = Suction & Discharge Tube, Oil Equalizer with Seal Nut, Grade 32 POE oil



General Information

Unit Description

The CGAM units are scroll type, air-cooled, liquid chillers, designed for installation outdoors. The 20-35 ton units have a single independent refrigerant circuit, with two compressors per circuit. The 40 ton and larger units have 2 independent refrigerant circuits, with two compressors per circuit. The CGAM units are packaged with an evaporator and condenser.

Note: Each CGAM unit is a completely assembled, hermetic -compressors packaged unit that is factory-piped, wired, leak-tested, dehydrated, charged and tested for proper control operations prior to shipment. The chilled water inlet and outlet openings are covered for shipment.

The CGAM series features Trane's exclusive Adaptive Control logic with CH530 controls. It monitors the control variables that govern the operation of the chiller unit. Adaptive Control logic can correct these variables, when necessary, to optimize operational efficiencies, avoid chiller shutdown, and keep producing chilled water.

Each refrigerant circuit is provided with filter, sight glass, electronic expansion valve, and charging valves on the CGAM.

The evaporator is a brazed plate heat exchanger which is equipped with a water drain and vent connections in the water piping. The condenser is an air-cooled slit or serpentine fin coil.

The condensers are available in three configurations depending on the tonnage of the unit. Units may be referred to the size by the condenser configuration. The three configurations are slant, V and W.

Figure 2. CGAM slant 20 to 35 ton configuration



Figure 3. CGAM "V" 40 to 70 ton configuration



Figure 4. CGAM "W" 80 to 130 ton configuration



Accessory/Options Information

Check all the accessories and loose parts which are shipped with the unit against the original order. Included in these items will be rigging diagrams, electrical diagrams, and service literature, which are placed inside the control panel and/or starter panel for shipment. Also check for optional components, such as isolators.

The unit elastomeric or seismic isolators and fan prop rod ship on brackets attached to the frame of the unit. The location varies by unit tonnage. The following figures show the location of these ship-with items for the various unit sizes.

Elastomeric pads required for units with wind load rating ship inside control panel.

Figure 5. Ship with location — elastomeric or seismic isolators and prop rod 20 to 35 ton units

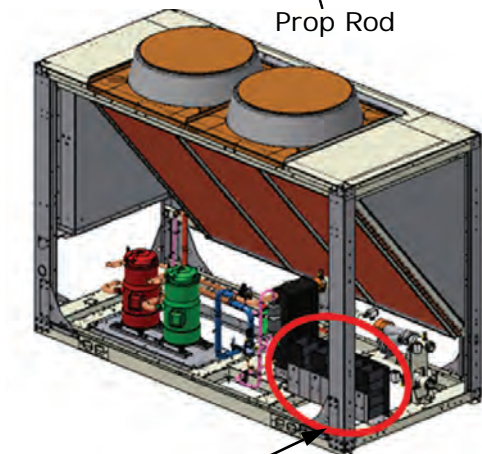
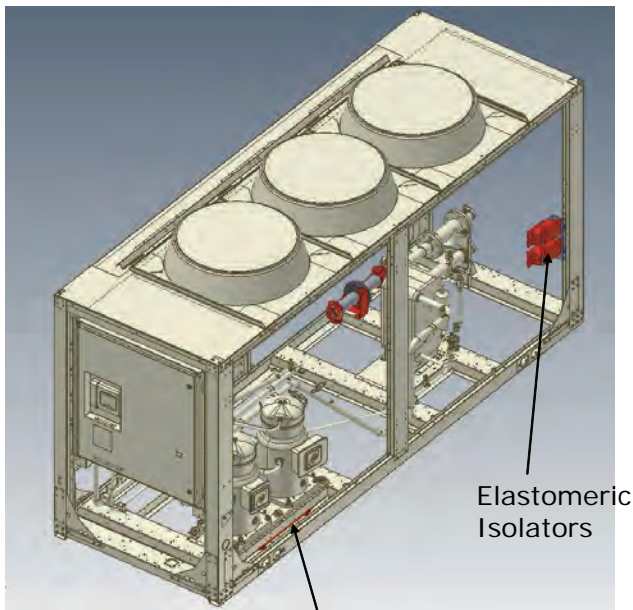
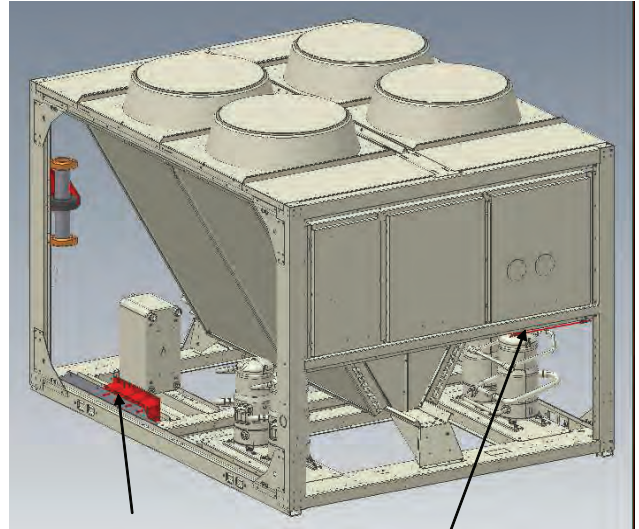
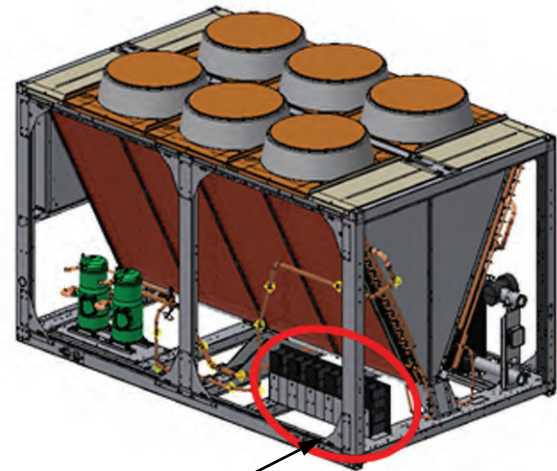

Figure 6. Ship with location — elastomeric or seismic isolators and prop rod 40 to 70 ton units



Elastomeric Isolators Prop Rod



Seismic Isolators

**Figure 7. Ship with location —
elastomeric or seismic isolator and prop rod
80 to130 ton units**

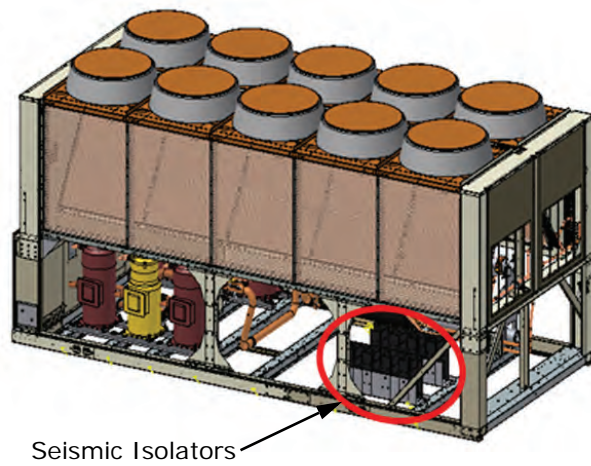
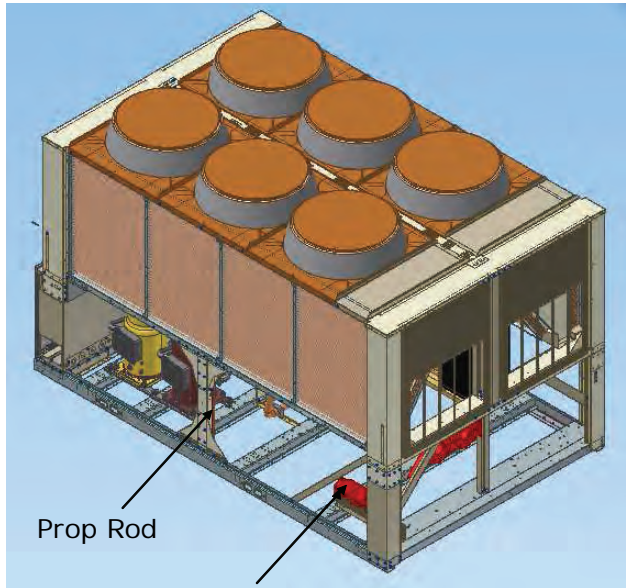



General Information

General Data

Table 1. General data, 60 Hz, high efficiency (I-P)

Size		20	26	30	35	40	52	60	70	80	90	100	110	120	130
Compressor															
Number	#	2	2	2	2	4	4	4	4	4	4	4	4	4	6
Tonnage/ckt ^(a)		10+10	13+13	15+15	15+20	10+10	13+13	15+15	15+20	20+20	20+25	25+25	25+30	30+30	20+20 +25
Evaporator															
Water storage	(gal)	1.4	2.2	2.2	3.2	2.4	4.1	5.0	7.5	7.0	9.0	10.3	11.5	11.5	12.3
Min. flow (LWT ≥42°F)	(gpm)	23.2	29.8	33.1	39.2	45.4	58.8	67.1	79.5	91.8	102.6	115.5	125.2	135.9	146.9
Min. flow (LWT 40 to 41.9°F)	(gpm)	29.1	37.2	41.8	49.1	56.7	73.5	83.9	99.4	114.7	128.3	144.4	156.5	169.9	183.7
Max. flow	(gpm)	69	89	100	117	136	176	201	238	275	307	346	375	407	440
Water connection	(in)	2	2.5	2.5	2.5	3	3	3	3	4	4	4	4	4	4
Condenser															
Round Tube and Plate Fin Coils															
Quantity of coils	#	1	1	1	1	2	2	2	2	4	4	4	4	4	4
Coil length	(in)	91	91	127	127	91	91	127	127	121	121	144	144	144	180
Coil height	(in)	68	68	68	68	68	68	68	68	42	42	42	42	42	42
Number of rows	#	2	2	2	2	2	2	2	2	3	3	3	3	3	3
Fins per foot	(fpf)	192	192	192	192	192	192	192	192	192	192	192	192	192	192
Microchannel Coils															
Quantity of coils	#	1	1	1	1	2	2	2	2	8	8	8	8	8	8
Coil length	(in)	91	91	127	127	91	91	127	127	68+46	68+46	68+68	68+68	68+68	68+ 104
Coil height ^(b)	(in)	42+10	42+10	42+10	42+10	42+10	42+10	42+10	42+10	34+7	34+7	34+7	34+7	34+7	34+7
Tube width	(in)	1	1	1	1	1	1	1	1	1	1	1	1	1	1
Fan															
Quantity	#	2	2	3	3	4	4	6	6	6	6	8	8	8	10
Diameter	(in)	28.8	28.8	28.8	28.8	28.8	28.8	28.8	28.8	28.8	28.8	28.8	28.8	28.8	28.8
Airflow per fan	(cfm)	9413	9420	9168	9173	9413	9420	9168	9173	9470	9472	9094	9096	9098	9094
Power per motor	(HP)	1.3	1.3	1.3	1.3	1.3	1.3	1.3	1.3	1.3	1.3	1.3	1.3	1.3	1.3
Motor RPM	(rpm)	840	840	840	840	840	840	840	840	840	840	840	840	840	840
Tip speed	(ft/min)	6333	6333	6333	6333	6333	6333	6333	6333	6333	6333	6333	6333	6333	6333
General Unit															
Refrig circuits	#	1	1	1	1	2	2	2	2	2	2	2	2	2	2
Capacity steps	%	50-100	50-100	50-100	43-100	25-50- 75-100	25-50- 75-100	25-50- 75-100	21-43- 71-100	25-50- 75-100	22-44- 72-100	25-50- 75-100	23-45- 73-100	25-50- 75-100	15-31- 46-62- 81-100
Min ambient - wide	(°F)	0	0	0	0	0	0	0	0	0	0	0	0	0	0
Min ambient - high	(°F)	32	32	32	32	32	32	32	32	32	32	32	32	32	32
Min ambient - extreme low	(°F)	-20	-20	-20	-20	-20	-20	-20	-20	-20	-20	-20	-20	-20	-20

Table 1. General data, 60 Hz, high efficiency (I-P) (continued)

Size		20	26	30	35	40	52	60	70	80	90	100	110	120	130
Round Tube and Plate Fin Coils															
Refrig charge/ckt(a)	(lbs)	32	34	44	48	32	32	44	48	74	78	90	86	86	112
Oil charge/ckt(a)	(gal)	1.7	1.7	1.9	3.5	1.7	1.7	1.9	3.5	3.5	3.5	3.5	3.7	3.8	5.8
Microchannel Coils															
Refrig charge/ckt (a)	(lbs)	19	22.5	28	35	19	20.5	28	35.5	45	47	49	46	50	66
Oil charge/ckt(a)	(gal)	1.4	1.4	1.6	2.9	1.4	1.4	1.6	2.9	2.9	2.9	2.9	3.0	3.1	5.4
Pump Package															
Avail head pressure(c)	(ft H ₂ O)	78.2	77.7	71.1	67.6	67.1	58.6	76.7	63.5	82.0	78.1	69.0	61.9	71.3	62.2
Power	(HP)	5	5	5	5	5	5	7.5	7.5	10	10	10	10	15	15
Expansion tank volume	(gal)	5	5	5	5	5	5	5	5	6	6	6	6	6	6
Buffer tank volume	(gal)	140	140	140	140	140	140	140	140	152	152	195	195	195	195
Partial Heat Recovery															
Water storage/ckt(a)	(gal)	0.02	0.02	0.02	0.03	0.02	0.02	0.02	0.03	0.03	0.04	0.04	0.04	0.06	0.06
Max flow	(gpm)	39	39	39	39	78	78	78	78	127	127	127	127	127	127
Water connection	(in)	1.5	1.5	1.5	1.5	1.5	1.5	1.5	1.5	2.5	2.5	2.5	2.5	2.5	2.5

(a) Data shown for one circuit only. The second circuit always matches.

(b) Microchannel coils are split horizontally between the condenser and subcooler coil.

(c) Pump available head pressure is based on 44/54°F evaporator with water, .0001 hr-ft²-°F/Btu, 95°F ambient and 0 ft elevation.



General Information

Table 2. General data, 60 Hz, high efficiency (SI)

Size		20	26	30	35	40	52	60	70	80	90	100	110	120	130
Compressor															
Number	#	2	2	2	2	4	4	4	4	4	4	4	4	4	6
Tonnage/ckt ^(a)		10+10	13+13	15+15	15+20	10+10	13+13	15+15	15+20	20+20	20+25	25+25	25+30	30+30	20+20 +25
Evaporator															
Water storage	(l)	5.3	8.3	8.3	12.1	9.1	15.5	18.9	28.4	26.5	34.1	39.0	43.5	43.5	46.6
Min. flow (LWT ≥5.56°C)	(l/s)	1.5	1.9	2.1	2.5	2.9	3.7	4.2	5.0	5.8	6.5	7.3	7.9	8.6	9.3
Min. flow (LWT 4.44 to 5.55°C)	(l/s)	1.8	2.3	2.6	3.1	3.6	4.6	5.3	6.3	7.2	8.1	9.1	9.9	10.7	11.6
Max. flow	(l/s)	4.4	5.6	6.3	7.4	8.6	11.1	12.7	15.1	17.4	19.4	21.9	23.7	25.7	27.8
Water connection	(mm)	50.8	63.5	63.5	63.5	76.2	76.2	76.2	76.2	101.6	101.6	101.6	101.6	101.6	101.6
Condenser															
Round Tube and Plate Fin Coils															
Qty of coils	#	1	1	1	1	2	2	2	2	4	4	4	4	4	4
Coil length	(mm)	2311	2311	3226	3226	2311	2311	3226	3226	3073	3073	3658	3658	3658	4572
Coil height	(mm)	1727	1727	1727	1727	1727	1727	1727	1727	1067	1067	1067	1067	1067	1067
Number of rows	#	2	2	2	2	2	2	2	2	3	3	3	3	3	3
Fins per foot	(fpf)	192	192	192	192	192	192	192	192	192	192	192	192	192	192
Microchannel Coils															
Quantity of coils	#	1	1	1	1	2	2	2	2	8	8	8	8	8	8
Coil length	(mm)	2311	2311	3226	3226	2311	2311	3226	3226	1727+ 1168	1727+ 1168	1727+ 1727	1727+ 1727	1727+ 1727	1727+ 2642
Coil height ^(b)	(mm)	1067+ 254	1067+ 254	1067+ 254	1067+ 254	1067+ 254	1067+ 254	1067+ 254	1067+ 254	864+ 178	864+ 178	864+ 178	864+ 178	864+ 178	864+ 178
Tube width	(mm)	25.4	25.4	25.4	25.4	25.4	25.4	25.4	25.4	25.4	25.4	25.4	25.4	25.4	25.4
Fan															
Quantity	#	2	2	3	3	4	4	6	6	4	6	8	8	8	10
Diameter	(mm)	732	732	732	732	732	732	732	732	732	732	732	732	732	732
Airflow per fan	(m ³ / h)	15993	16005	15577	15585	15993	16005	15577	15585	16090	16093	15451	15454	15458	15451
Power per motor	(HP)	1.3	1.3	1.3	1.3	1.3	1.3	1.3	1.3	1.3	1.3	1.3	1.3	1.3	1.3
Motor RPM	(rpm)	840	840	840	840	840	840	840	840	840	840	840	840	840	840
Tip speed	(m/s)	32	32	32	32	32	32	32	32	32	32	32	32	32	32
General Unit															
Refrig circuits	#	1	1	1	1	2	2	2	2	2	2	2	2	2	2
Capacity steps	%	50-100	50-100	50-100	43-100	25-50- 75-100	25-50- 75-100	25-50- 75-100	21-43- 71-100	25-50- 75-100	22-44- 72-100	25-50- 75-100	23-45- 73-100	25-50- 75-100	15-31- 46-62- 81-100
Min ambient - wide	(°C)	-18	-18	-18	-18	-18	-18	-18	-18	-18	-18	-18	-18	-18	-18
Min ambient - high	(°C)	0	0	0	0	0	0	0	0	0	0	0	0	0	
Min ambient - extreme low	(°C)	-28.9	-28.9	-28.9	-28.9	-28.9	-28.9	-28.9	-28.9	-28.9	-28.9	-28.9	-28.9	-28.9	-28.9

Table 2. General data, 60 Hz, high efficiency (SI) (continued)

Size	20	26	30	35	40	52	60	70	80	90	100	110	120	130
Round Tube and Plate Fin Coils														
Refrig charge/ckt(a) (kg)	14.5	15.4	20	21.8	14.5	14.5	20	21.8	33.6	35.4	40.8	39	39	50.8
Oil charge /ckt(a) (l)	6.6	6.6	7.2	13.4	6.6	6.6	7.2	13.4	13.4	13.4	13.4	13.9	14.4	22.0
Microchannel Coils														
Refrig charge/ckt(a) (kg)	8.6	10.2	12.7	15.9	8.6	9.3	12.7	16.1	20.4	21.3	22.2	20.9	22.7	29.9
Oil charge /ckt(a) (l)	5.4	5.4	5.9	11.0	5.4	5.4	5.9	11.0	11.0	11.0	11.0	11.4	11.8	18.0
Pump Package														
Avail head pressure(c) (kPa)	233.7	232.3	212.6	202.1	200.6	175.0	229.2	189.7	245.1	233.3	206.3	185.0	213.1	185.8
Power (HP)	5	5	5	5	5	5	7.5	7.5	10	10	10	10	15	15
Expansion tank volume (l)	18.9	18.9	18.9	18.9	18.9	18.9	18.9	18.9	22.7	22.7	22.7	22.7	22.7	22.7
Buffer tank volume (l)	530	530	530	530	530	530	530	530	575	575	727	727	727	727
Partial Heat Recovery														
Water storage/ckt(a) (l)	0.07	0.09	0.09	0.11	0.07	0.09	0.09	0.11	0.12	0.16	0.16	0.16	0.21	0.21
Max flow (l/s)	2.5	2.5	2.5	2.5	5.0	5.0	5.0	5.0	8.0	8.0	8.0	8.0	8.0	8.0
Water connection (mm)	38.1	38.1	38.1	38.1	38.1	38.1	38.1	38.1	63.5	63.5	63.5	63.5	63.5	63.5

(a) Data shown for one circuit only. The second circuit always matches.

(b) Microchannel coils are split horizontally between the condenser and subcooler coil.

(c) Pump available head pressure is based on 6.7/12.2°C evaporator with water, .01761 m²°C/kW, 35°C ambient and 0 m elevation.



General Information

Table 3. General data, 50 Hz, high efficiency (I-P)

Size		20	26	30	35	40	52	60	70	80	90	100	110	120
Compressor														
Number	#	2	2	2	2	4	4	4	4	4	4	4	4	4
Tonnage/ckt ^(a)		10+10	13+13	15+15	15+20	10+10	13+13	15+15	15+20	20+20	20+25	25+25	25+30	30+30
Evaporator														
Water storage	(gal)	1.4	2.2	2.2	3.2	2.4	4.1	5.0	7.5	7.0	9.0	10.3	11.5	11.5
Min. flow (LWT ≥42°F)	(gpm)	19.7	25.1	28.2	32.7	38.1	49.4	56.4	66.0	77.5	86.8	98.0	105.8	113.1
Min. flow (LWT 40 to 41.9°F)	(gpm)	24.6	31.3	35.3	40.9	47.7	61.8	70.5	82.5	96.9	108.5	122.5	132.3	141.4
Max. flow	(gpm)	59	75	85	98	115	149	170	199	234	262	296	319	341
Water connection	(in)	2	2.5	2.5	2.5	3	3	3	3	4	4	4	4	4
Condenser														
Round Tube and Plate Fin Coils														
Quantity of coils	#	1	1	1	1	2	2	2	2	4	4	4	4	4
Coil length	(in)	91	91	127	127	91	91	127	127	121	121	144	144	144
Coil height	(in)	68	68	68	68	68	68	68	68	42	42	42	42	42
Number of rows	#	2	2	2	2	2	2	2	2	3	3	3	3	3
Fins per foot	(fpf)	192	192	192	192	192	192	192	192	192	192	192	192	192
Microchannel Coils														
Quantity of coils	#	1	1	1	1	2	2	2	2	8	8	8	8	8
Coil length	(in)	91	91	127	127	91	91	127	127	68+46	68+46	68+68	68+68	68+68
Coil height ^(b)	(in)	42+10	42+10	42+10	42+10	42+10	42+10	42+10	42+10	34+7	34+7	34+7	34+7	34+7
Tube width	(in)	1	1	1	1	1	1	1	1	1	1	1	1	1
Fan														
Quantity	#	2	2	3	3	4	4	6	6	6	6	8	8	8
Diameter	(in)	28.8	28.8	28.8	28.8	28.8	28.8	28.8	28.8	28.8	28.8	28.8	28.8	28.8
Airflow per fan	(cfm)	7796	7783	7587	7590	7795	7801	7587	7590	7827	7829	7503	7505	7506
Power per motor	(HP)	1.3	1.3	1.3	1.3	1.3	1.3	1.3	1.3	1.3	1.3	1.3	1.3	1.3
Motor RPM	(rpm)	700	700	700	700	700	700	700	700	700	700	700	700	700
Tip speed	(ft/min)	5278	5278	5278	5278	5278	5278	5278	5278	5278	5278	5278	5278	5278
General Unit														
Refrig circuits	#	1	1	1	1	2	2	2	2	2	2	2	2	2
Capacity steps	%	50-100	50-100	50-100	43-100	25-50-75-100	25-50-75-100	25-50-75-100	21-43-71-100	25-50-75-100	22-44-72-100	25-50-75-100	23-45-73-100	25-50-75-100
Min ambient - wide	(°F)	0	0	0	0	0	0	0	0	0	0	0	0	0
Min ambient - high	(°F)	32	32	32	32	32	32	32	32	32	32	32	32	32
Round Tube and Plate Fin Coils														
Refrig charge/ckt ^(a)	(lbs)	32	34	44	48	32	32	44	48	74	78	90	86	86
Oil charge/ckt ^(a)	(gal)	1.7	1.7	1.9	3.5	1.7	1.7	1.9	3.5	3.5	3.5	3.5	3.7	3.8
Microchannel Coils														
Refrig charge/ckt ^(a)	(lbs)	19	22.5	28	35	19	20.5	28	35.5	45	47	49	46	50
Oil charge/ckt ^(a)	(gal)	1.4	1.4	1.6	2.9	1.4	1.4	1.6	2.9	2.9	2.9	2.9	3.0	3.1
Partial Heat Recovery														
Water storage/ckt ^(a)	(gal)	0.02	0.02	0.02	.02	0.02	0.02	0.02	0.02	0.03	0.03	0.03	0.04	0.04
Max flow	(gpm)	39	39	39	39	78	78	78	78	127	127	127	127	127
Water connection	(in)	1.5	1.5	1.5	1.5	1.5	1.5	1.5	1.5	2.5	2.5	2.5	2.5	2.5

(a) Data shown for one circuit only. The second circuit always matches.

(b) Microchannel coils are split horizontally between the condenser and subcooler coil.

Table 4. General data, 50 Hz, high efficiency (SI)

Size		20	26	30	35	40	52	60	70	80	90	100	110	120
Compressor														
Number	#	2	2	2	2	4	4	4	4	4	4	4	4	4
Tonnage/ckt ^(a)		10+10	13+13	15+15	15+20	10+10	13+13	15+15	15+20	20+20	20+25	25+25	25+30	30+30
Evaporator														
Water storage	(l)	5.3	8.3	8.3	12.1	9.1	15.5	18.9	28.4	26.5	34.1	39.0	43.5	43.5
Min. flow (LWT ≥5.56°C)	(l/s)	1.2	1.6	1.8	2.1	2.4	3.1	3.6	4.2	4.9	5.5	6.2	6.7	7.1
Min. flow (LWT 4.44 to 5.55°C)	(l/s)	1.6	2.0	2.2	2.6	3.0	3.9	4.4	5.2	6.1	6.8	7.7	8.3	8.9
Max. flow	(l/s)	3.7	4.8	5.4	6.2	7.3	9.4	10.8	12.6	14.8	16.5	18.7	20.2	21.6
Water connection	(mm)	50.8	63.5	63.5	63.5	76.2	76.2	76.2	76.2	101.6	101.6	101.6	101.6	101.6
Condenser														
Round Tube and Plate Fin Coils														
Quantity of coils	#	1	1	1	1	2	2	2	2	4	4	4	4	4
Coil length	(mm)	2311	2311	3226	3226	2311	2311	3226	3226	3073	3073	3658	3658	3658
Coil height	(mm)	1727	1727	1727	1727	1727	1727	1727	1727	1067	1067	1067	1067	1067
Number of rows	#	2	2	2	2	2	2	2	2	3	3	3	3	3
Fins per foot	(fpf)	192	192	192	192	192	192	192	192	192	192	192	192	192
Microchannel Coils														
Quantity of coils	#	1	1	1	1	2	2	2	2	8	8	8	8	8
Coil length	(mm)	2311	2311	3226	3226	2311	2311	3226	3226	1727+ 1168	1727+ 1168	1727+ 1727	1727+ 1727	1727+ 1727
Coil height ^(b)	(mm)	1067+ 254	1067+ 254	1067+ 254	1067+ 254	1067+ 254	1067+ 254	1067+ 254	1067+ 254	864+ 178	864+ 178	864+ 178	864+ 178	864+ 178
Tube width	(mm)	25.4	25.4	25.4	25.4	25.4	25.4	25.4	25.4	25.4	25.4	25.4	25.4	25.4
Fan														
Quantity	#	2	2	3	3	4	4	6	6	6	6	8	8	8
Diameter	(mm)	732	732	732	732	732	732	732	732	732	732	732	732	732
Airflow per fan	(m ³ /h)	13245	13223	12890	12895	13244	13254	12890	12895	13298	13302	12748	12751	12753
Power per motor	(HP)	1.3	1.3	1.3	1.3	1.3	1.3	1.3	1.3	1.3	1.3	1.3	1.3	1.3
Motor RPM	(rpm)	700	700	700	700	700	700	700	700	700	700	700	700	700
Tip speed	(m/s)	26.8	26.8	26.8	26.8	26.8	26.8	26.8	26.8	26.8	26.8	26.8	26.8	26.8
General Unit														
Refrig circuits	#	1	1	1	1	2	2	2	2	2	2	2	2	2
Capacity steps	%	50-100	50-100	50-100	43-100	25-50- 75-100	25-50- 75-100	25-50- 75-100	21-43- 71-100	25-50- 75-100	22-44- 72-100	25-50- 75-100	23-45- 73-100	25-50- 75-100
Min ambient - wide	(°C)	-18	-18	-18	-18	-18	-18	-18	-18	-18	-18	-18	-18	-18
Min ambient - high	(°C)	0	0	0	0	0	0	0	0	0	0	0	0	
Round Tube and Plate Fin Coils														
Refrig charge/ckt ^(a)	(kg)	14.5	15.4	20	21.8	14.5	14.5	20	21.8	33.6	35.4	40.8	39	39
Oil charge/ckt ^(a)	(l)	6.6	6.6	7.2	13.4	6.6	6.6	7.2	13.4	13.4	13.4	13.4	13.9	14.4
Microchannel Coils														
Refrig charge/ckt ^(a)	(kg)	8.6	10.2	12.7	15.9	8.6	9.3	12.7	16.1	20.4	21.3	22.2	20.9	22.7
Oil charge/ckt ^(a)	(l)	5.4	5.4	5.9	11.0	5.4	5.4	5.9	11.0	11.0	11.0	11.0	11.4	11.8
Partial Heat Recovery														
Water storage/ckt ^(a)	(l)	0.07	0.07	0.09	0.09	0.07	0.07	0.09	0.09	0.12	0.12	0.12	0.16	0.16
Max flow	(l/s)	2.5	2.5	2.5	2.5	5.0	5.0	5.0	5.0	8.0	8.0	8.0	8.0	8.0
Water connection	(mm)	38.1	38.1	38.1	38.1	38.1	38.1	38.1	38.1	63.5	63.5	63.5	63.5	63.5

(a) Data shown for one circuit only. The second circuit always matches.

(b) Microchannel coils are split horizontally between the condenser and subcooler coil.



General Information

Table 5. General data, 60 Hz, extra efficiency (I-P)

Size		20	26	30	35	40	52	60	70	110	120
Compressor											
Number	#	2	2	2	2	4	4	4	4	4	4
Tonnage/ckt ^(a)		10+10	13+13	15+15	15+20	10+10	13+13	15+15	15+20	25+30	30+30
Evaporator											
Water storage	(gal)	1.4	2.2	2.2	3.2	2.4	4.1	5.0	7.5	11.5	11.5
Min. flow (LWT ≥42°F)	(gpm)	23.2	29.8	33.1	39.2	45.4	58.8	67.1	79.5	125.2	135.9
Min. flow (LWT 40 to 41.9°F)	(gpm)	29.1	37.2	41.8	49.1	56.7	73.5	83.9	99.4	156.5	169.9
Max. flow	(gpm)	69	89	100	117	136	176	201	238	375	407
Water connection	(in)	2	2.5	2.5	2.5	3	3	3	3	4	4
Condenser											
Round Tube and Plate Fin Coils											
Quantity of coils	#	1	1	1	1	2	2	2	2	4	4
Coil length	(in)	91	91	127	127	91	91	127	127	144	144
Coil height	(in)	68	68	68	68	68	68	68	68	42	42
Number of rows	#	3	3	3	3	3	3	3	3	3	3
Fins per foot	(fpf)	192	192	192	192	192	192	192	192	192	192
Fan											
Quantity	#	2	2	3	3	4	4	6	6	8	8
Diameter	(in)	28.8	28.8	28.8	28.8	28.8	28.8	28.8	28.8	28.8	28.8
Airflow per fan	(cfm)	9413	9420	9168	9173	9413	9420	9168	9173	9096	9098
Power per motor	(HP)	1.3	1.3	1.3	1.3	1.3	1.3	1.3	1.3	1.3	1.3
Motor RPM	(rpm)	840	840	840	840	840	840	840	840	840	840
Tip speed	(ft/min)	6333	6333	6333	6333	6333	6333	6333	6333	6333	6333
General Unit											
Refrig circuits	#	1	1	1	1	2	2	2	2	2	2
Capacity steps	%	50-100	50-100	50-100	43-100	25-50- 75-100	25-50- 75-100	25-50- 75-100	21-43- 71-100	23-45- 73-100	25-50- 75-100
Min ambient - wide	(°F)	0	0	0	0	0	0	0	0	0	0
Min ambient - high	(°F)	32	32	32	32	32	32	32	32	32	32
Round Tube and Plate Fin Coils											
Refrig charge/ckt ^(a)	(lbs)	45	48	62	68	42	42	57	62	86	86
Oil charge/ckt ^(a)	(gal)	1.7	1.7	1.9	3.5	1.7	1.7	1.9	3.5	3.7	3.8
Pump Package											
Avail head pressure ^(b)	(ft H ₂ O)	78.2	77.7	71.1	67.6	67.1	58.6	76.7	63.5	61.9	71.3
Power	(HP)	5	5	5	5	5	5	7.5	7.5	10	15
Expansion tank volume	(gal)	5	5	5	5	5	5	5	5	6	6
Buffer tank volume	(gal)	140	140	140	140	140	140	140	140	195	195
Partial Heat Recovery											
Water storage/ckt ^(a)	(gal)	0.02	0.02	0.02	0.03	0.02	0.02	0.02	0.03	0.04	0.06
Max flow	(gpm)	39	39	39	39	78	78	78	78	127	127
Water connection	(in)	1.5	1.5	1.5	1.5	1.5	1.5	1.5	1.5	2.5	2.5

(a) Data shown for one circuit only. The second circuit always matches.

(b) Pump available head pressure is based on 44/54°F evaporator with water, .0001 hr-ft²-°F/Btu, 95°F ambient and 0 ft elevation.

Table 6. General data, 60 Hz, extra efficiency (SI)

Size		20	26	30	35	40	52	60	70	110	120
Compressor											
Number #		2	2	2	2	4	4	4	4	4	4
Tonnage/ckt ^(a)		10+10	13+13	15+15	15+20	10+10	13+13	15+15	15+20	25+30	30+30
Evaporator											
Water storage (l)		5.3	8.3	8.3	12.1	9.1	15.5	18.9	28.4	43.5	43.5
Min. flow (LWT ≥5.56°C) (l/s)		1.5	1.9	2.1	2.5	2.9	3.7	4.2	5.0	7.9	8.6
Min. flow (LWT 4.44 to 5.55°C) (l/s)		1.8	2.3	2.6	3.1	3.6	4.6	5.3	6.3	9.9	10.7
Max. flow (l/s)		4.4	5.6	6.3	7.4	8.6	11.1	12.7	15.1	23.7	25.7
Water connection (mm)		50.8	63.5	63.5	63.5	76.2	76.2	76.2	76.2	101.6	101.6
Condenser											
Round Tube and Plate Fin Coils											
Qty of coils #		1	1	1	1	2	2	2	2	4	4
Coil length (mm)		2311	2311	3226	3226	2311	2311	3226	3226	3658	3658
Coil height (mm)		1727	1727	1727	1727	1727	1727	1727	1727	1067	1067
Number of rows #		3	3	3	3	3	3	3	3	3	3
Fins per foot (fpf)		192	192	192	192	192	192	192	192	192	192
Fan											
Quantity #		2	2	3	3	4	4	6	6	8	8
Diameter (mm)		732	732	732	732	732	732	732	732	732	732
Airflow per fan (m ³ /h)		15993	16005	15577	15585	15993	16005	15577	15585	15454	15458
Power per motor (HP)		1.3	1.3	1.3	1.3	1.3	1.3	1.3	1.3	1.3	1.3
Motor RPM (rpm)		840	840	840	840	840	840	840	840	840	840
Tip speed (m/s)		32	32	32	32	32	32	32	32	32	32
General Unit											
Refrig circuits #		1	1	1	1	2	2	2	2	2	2
Capacity steps %		50-100	50-100	50-100	43-100	25-50-75-100	25-50-75-100	25-50-75-100	21-43-71-100	23-45-73-100	25-50-75-100
Min ambient - wide (°C)		-18	-18	-18	-18	-18	-18	-18	-18	-18	-18
Min ambient - high (°C)		0	0	0	0	0	0	0	0	0	0
Round Tube and Plate Fin Coils											
Refrig charge/ckt ^(a) (kg)		20.4	21.8	28.1	30.8	19.1	19.1	25.9	28.1	39	39
Oil charge /ckt ^(a) (l)		6.6	6.6	7.2	13.4	6.6	6.6	7.2	13.4	13.9	14.4
Pump Package											
Avail head pressure ^(b) (kPa)		233.7	232.3	212.6	202.1	200.6	175.0	229.2	189.7	185.0	213.1
Power (HP)		5	5	5	5	5	5	7.5	7.5	10	15
Expansion tank volume (l)		18.9	18.9	18.9	18.9	18.9	18.9	18.9	18.9	22.7	22.7
Buffer tank volume (l)		530	530	530	530	530	530	530	530	727	727
Partial Heat Recovery											
Water storage/ckt ^(a) (l)		0.07	0.09	0.09	0.11	0.07	0.09	0.09	0.11	0.16	0.21
Max flow (l/s)		2.5	2.5	2.5	2.5	5.0	5.0	5.0	5.0	8.0	8.0
Water connection (mm)		38.1	38.1	38.1	38.1	38.1	38.1	38.1	38.1	63.5	63.5

(a) Data shown for one circuit only. The second circuit always matches.

(b) Pump available head pressure is based on 6.7/12.2°C evaporator with water, .01761 m²/C/kW, 35°C ambient and 0 m elevation.



General Information

Table 7. General data, 50 Hz, extra efficiency (I-P)

Size		20	26	30	35	40	52	60	70	110	120
Compressor											
Number	#	2	2	2	2	4	4	4	4	4	4
Tonnage/ckt ^(a)		10+10	13+13	15+15	15+20	10+10	13+13	15+15	15+20	25+30	30+30
Evaporator											
Water storage	(gal)	1.4	2.2	2.2	3.2	2.4	4.1	5.0	7.5	11.5	11.5
Min. flow (LWT ≥42°F)	(gpm)	19.7	25.1	28.2	32.7	38.1	49.4	56.4	66.0	105.8	113.1
Min. flow (LWT 40 to 41.9°F)	(gpm)	24.6	31.3	35.3	40.9	47.7	61.8	70.5	82.5	132.3	141.4
Max. flow	(gpm)	59	75	85	98	115	149	170	199	319	341
Water connection	(in)	2	2.5	2.5	2.5	3	3	3	3	4	4
Condenser											
Round Tube and Plate Fin Coils											
Quantity of coils	#	1	1	1	1	2	2	2	2	4	4
Coil length	(in)	91	91	127	127	91	91	127	127	144	144
Coil height	(in)	68	68	68	68	68	68	68	68	42	42
Number of rows	#	2	2	2	2	2	2	2	2	3	3
Fins per foot	(fpf)	192	192	192	192	192	192	192	192	192	192
Fan											
Quantity	#	2	2	3	3	4	4	6	6	8	8
Diameter	(in)	28.8	28.8	28.8	28.8	28.8	28.8	28.8	28.8	28.8	28.8
Airflow/fan	(cfm)	7796	7783	7587	7590	7795	7801	7587	7590	7505	7506
Power/motor	(HP)	1.3	1.3	1.3	1.3	1.3	1.3	1.3	1.3	1.3	1.3
Motor RPM	(rpm)	700	700	700	700	700	700	700	700	700	700
Tip speed	(ft/min)	5278	5278	5278	5278	5278	5278	5278	5278	5278	5278
General Unit											
Refrig circuits	#	1	1	1	1	2	2	2	2	2	2
Capacity steps	%	50-100	50-100	50-100	43-100	25-50- 75-100	25-50- 75-100	25-50- 75-100	21-43- 71-100	23-45- 73-100	25-50- 75-100
Min ambient - wide	(°F)	0	0	0	0	0	0	0	0	0	0
Min ambient - high	(°F)	32	32	32	32	32	32	32	32	32	32
Round Tube and Plate Fin Coils											
Refrig charge/ckt ^(a)	(lbs)	45	48	62	68	42	42	57	62	86	86
Oil charge/ckt ^(a)	(gal)	1.7	1.7	1.9	3.5	1.7	1.7	1.9	3.5	3.7	3.8
Partial Heat Recovery											
Water storage/ckt ^(a)	(gal)	0.02	0.02	0.02	.02	0.02	0.02	0.02	0.02	0.04	0.04
Max flow	(gpm)	39	39	39	39	78	78	78	78	127	127
Water connection	(in)	1.5	1.5	1.5	1.5	1.5	1.5	1.5	1.5	2.5	2.5

(a) Data shown for circuit one only. The second circuits always matches.

Table 8. General data, 50 Hz, extra efficiency (SI)

Size		20	26	30	35	40	52	60	70	110	120
Compressor											
Number	#	2	2	2	2	4	4	4	4	4	4
Tonnage/ckt ^(a)		10+10	13+13	15+15	15+20	10+10	13+13	15+15	15+20	25+30	30+30
Evaporator											
Water storage	(l)	5.3	8.3	8.3	12.1	9.1	15.5	18.9	28.4	43.5	43.5
Min. flow (LWT ≥5.56°C)	(l/s)	1.2	1.6	1.8	2.1	2.4	3.1	3.6	4.2	6.7	7.1
Min. flow (LWT 4.44 to 5.55°C)	(l/s)	1.6	2.0	2.2	2.6	3.0	3.9	4.4	5.2	8.3	8.9
Max. flow	(l/s)	3.7	4.8	5.4	6.2	7.3	9.4	10.8	12.6	20.2	21.6
Water connection	(mm)	50.8	63.5	63.5	63.5	76.2	76.2	76.2	76.2	101.6	101.6
Condenser											
Round Tube and Plate Fin Coils											
Quantity of coils	#	1	1	1	1	2	2	2	2	4	4
Coil length	(mm)	2311	2311	3226	3226	2311	2311	3226	3226	3658	3658
Coil height	(mm)	1727	1727	1727	1727	1727	1727	1727	1727	1067	1067
Number of rows	#	2	2	2	2	2	2	2	2	3	3
Fins per foot	(fpf)	192	192	192	192	192	192	192	192	192	192
Fan											
Quantity	#	2	2	3	3	4	4	6	6	8	8
Diameter	(mm)	732	732	732	732	732	732	732	732	732	732
Airflow/fan	(m ³ /h)	13245	13223	12890	12895	13244	13254	12890	12895	12751	12753
Power/motor	(HP)	1.3	1.3	1.3	1.3	1.3	1.3	1.3	1.3	1.3	1.3
Motor RPM	(rpm)	700	700	700	700	700	700	700	700	700	700
Tip speed	(m/s)	26.8	26.8	26.8	26.8	26.8	26.8	26.8	26.8	26.8	26.8
General Unit											
Refrig circuits	#	1	1	1	1	2	2	2	2	2	2
Capacity steps	%	50-100	50-100	50-100	43-100	25-50- 75-100	25-50- 75-100	25-50- 75-100	21-43- 71-100	23-45- 73-100	25-50- 75-100
Min ambient - wide	(°C)	-18	-18	-18	-18	-18	-18	-18	-18	-18	-18
Min ambient - high	(°C)	0	0	0	0	0	0	0	0	0	0
Round Tube and Plate Fin Coils											
Refrig charge/ckt ^(a)	(kg)	20.4	21.8	28.1	30.8	19.1	19.1	25.9	28.1	39	39
Oil charge/ckt ^(a)	(l)	6.6	6.6	7.2	13.4	6.6	6.6	7.2	13.4	13.9	14.4
Partial Heat Recovery											
Water storage/ckt ^(a)	(l)	0.07	0.07	0.09	0.09	0.07	0.07	0.09	0.09	0.16	0.16
Max flow	(l/s)	2.5	2.5	2.5	2.5	5.0	5.0	5.0	5.0	8.0	8.0
Water connection	(mm)	38.1	38.1	38.1	38.1	38.1	38.1	38.1	38.1	63.5	63.5

(a) Data shown for circuit one only. The second circuit always matches.



Pre-Installation

Inspection Checklist

When the unit is delivered, verify that it is the correct unit and that it is properly equipped. Compare the information which appears on the unit nameplate with the ordering and submittal information.

Inspect all exterior components for visible damage. Report any apparent damage or material shortage to the carrier and make a "unit damage" notation on the carrier's delivery receipt. Specify the extent and type of damage found and notify the appropriate Trane Sales Office.

Do not proceed with installation of a damaged unit without sales office approval.

To protect against loss due to damage incurred in transit, complete the following checklist upon receipt of the unit.

- Inspect the individual pieces of the shipment before accepting the unit. Check for obvious damage to the unit or packing material.
- Inspect the unit for concealed damage as soon as possible after delivery and before it is stored. Concealed damage must be reported within 15 days.
- If concealed damage is discovered, stop unpacking the shipment. Do not remove damaged material from the receiving location. Take photos of the damage, if possible. The owner must provide reasonable evidence that the damage did not occur after delivery.
- Notify the carrier's terminal of the damage immediately, by phone and by mail. Request an immediate, joint inspection of the damage with the carrier and the consignee.
- Notify the Trane sales representative and arrange for repair. Do not repair the unit, however, until damage is inspected by the carrier's representative.

Unit Storage

If the chiller is to be stored in ambients of 32°F or less, evaporator should be blown out to remove any liquid and refrigerant isolation valves should be closed.

If the chiller is to be stored for more than one month prior to installation, observe the following precautions:

- Do not remove the protective coverings from the electrical panel.
- Store the chiller in a secure area.
- Units charged with refrigerant should not be stored where temperatures exceed 155°F.
- At least every three months, attach a gauge and manually check the pressure in the refrigerant circuit. If the refrigerant pressure is below 200 psig at 70 F (or 145 psig at 50 F), call a qualified service organization and the appropriate Trane sales office.

Note: Pressure will be approximately 20 psig if shipped with the optional nitrogen charge.

Installation Requirements

A list of the contractor responsibilities typically associated with the unit installation process is provided.

Type	Trane Supplied		Field Supplied Field Installed
	Trane Installed	Field Installed	
Foundation			<ul style="list-style-type: none"> • Meet foundation requirements
Rigging			<ul style="list-style-type: none"> • Safety chains • Clevis connectors • Lifting beam
Isolation		<ul style="list-style-type: none"> • Elastomeric isolators (optional) 	<ul style="list-style-type: none"> • Elastomeric isolators (optional)
Electrical	<ul style="list-style-type: none"> • Circuit breakers (optional) • Unit mounted starter 		<ul style="list-style-type: none"> • Circuit breakers (optional) • Electrical connections to unit mounted starter • Wiring sizes per submittal and NEC • Terminal lugs • Ground connection(s) • BAS wiring (optional) • Control voltage wiring • Chilled water pump contactor and wiring including interlock • Option relays and wiring
Water piping	<ul style="list-style-type: none"> • Flow switch • Water strainer 		<ul style="list-style-type: none"> • Taps for thermometers and gauges • Thermometers • Water flow pressure gauges • Isolation and balancing valves in water piping • Vents and drain • Pressure relief valves
Insulation		<ul style="list-style-type: none"> • Insulation • High humidity insulation (optional) 	<ul style="list-style-type: none"> • Insulation
Water Piping Connection Components	<ul style="list-style-type: none"> • Grooved pipe 		
Other Materials		<ul style="list-style-type: none"> • R-410A refrigerant (1 lb. max per machine as needed) • Dry nitrogen (20 psig max per machine as needed) 	



Dimensions and Weights

Service Clearances

Figure 8. CGAM service clearances

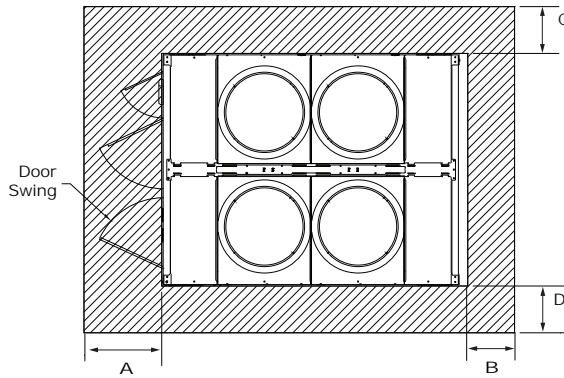

Table 9. CGAM service clearance dimensions

Unit Size	A		B		C		D	
	in	mm	in	mm	in	mm	in	mm
20 to 35 ton	47.2	1200	31.5	800	23.6	600	39.4	1000
40 to 70 ton	47.2	1200	31.5	800	39.4	1000	39.4	1000
80 to 130 ton	47.2	1200	39.4	1000	39.4	1000	39.4	1000

Notes:

- Number of fans and panel doors shown does not represent the number of fans installed.
- More clearance may be needed for airflow, depending on installation.

Mounting Locations

Important: All mounting holes are 0.75 in (19mm) in diameter.

Unit without Wind Load Rating

Note: Mounting locations shown below are for units without wind load rating. For units with wind load rating (model number digit 17=D), additional

mounting points are required. See “Units with Wind Load Rating,” p. 29.

Figure 9. Mounting locations, 20 to 35 ton

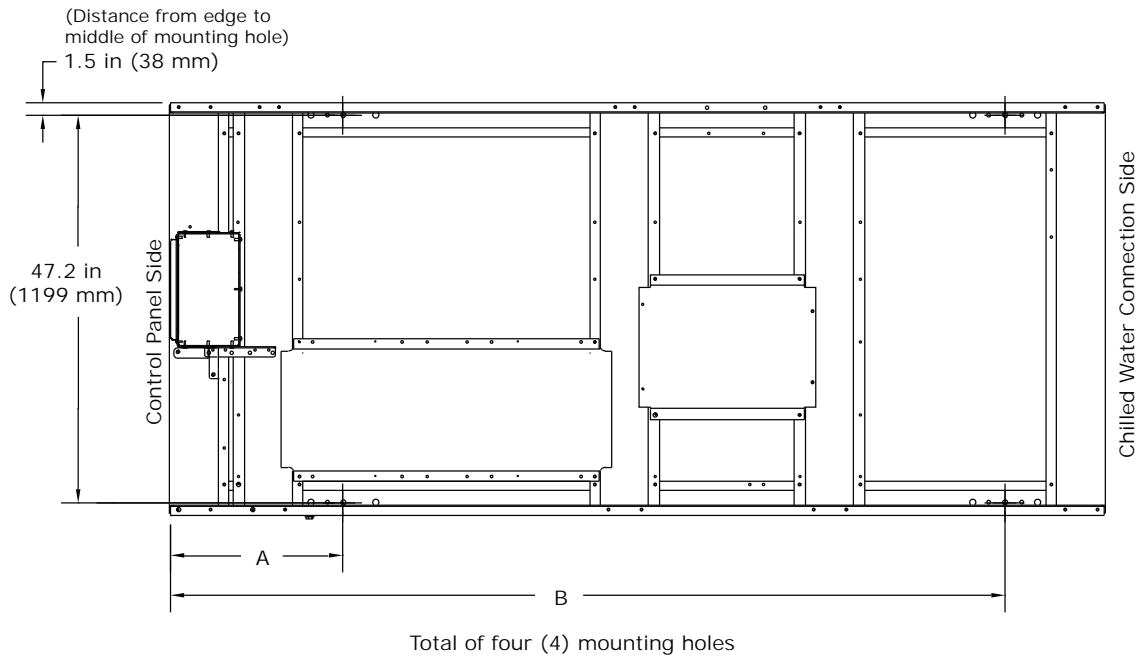

Table 10. Mounting locations, 20 to 35 ton units without wind load option

Unit Size (tons)	A		B	
	in	mm	in	mm
20, 26	21.0	533	101.2	2570
30, 35	21.9	556	132.2	3358

Figure 10. Mounting locations, 40 and 52 ton

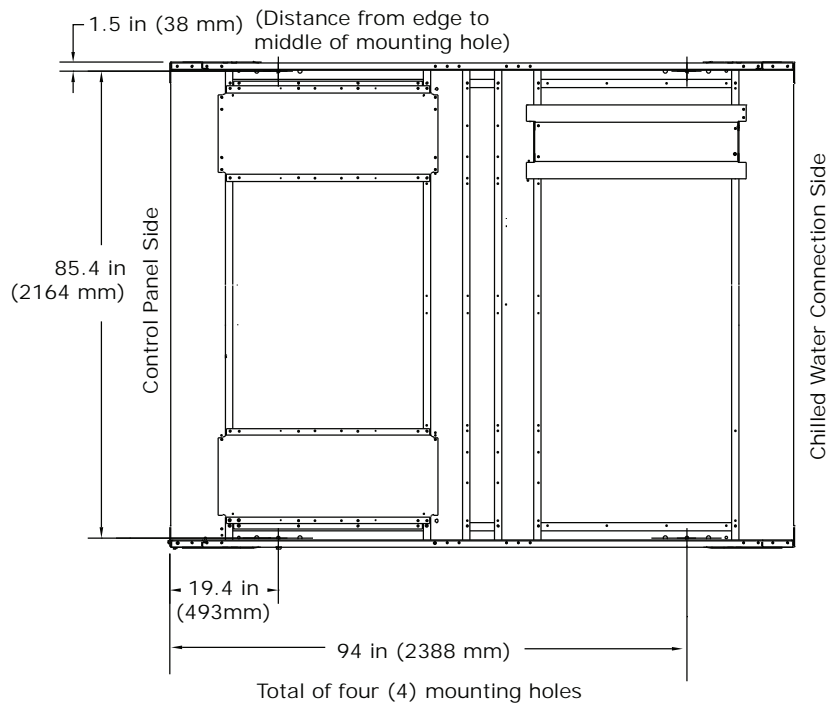
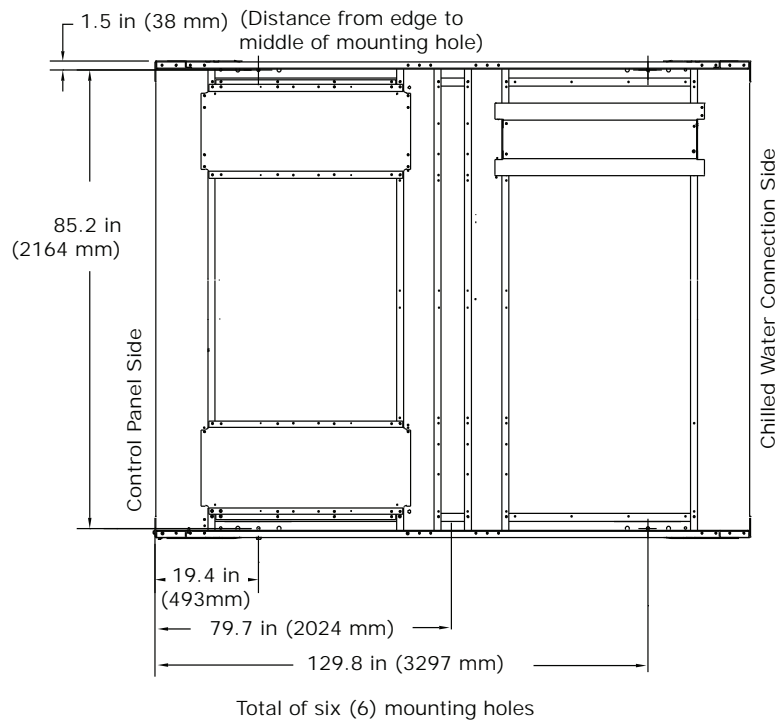

Figure 11. Mounting locations, 60 and 70 ton



Dimensions and Weights

Figure 12. Mounting locations, 80 to 120 ton

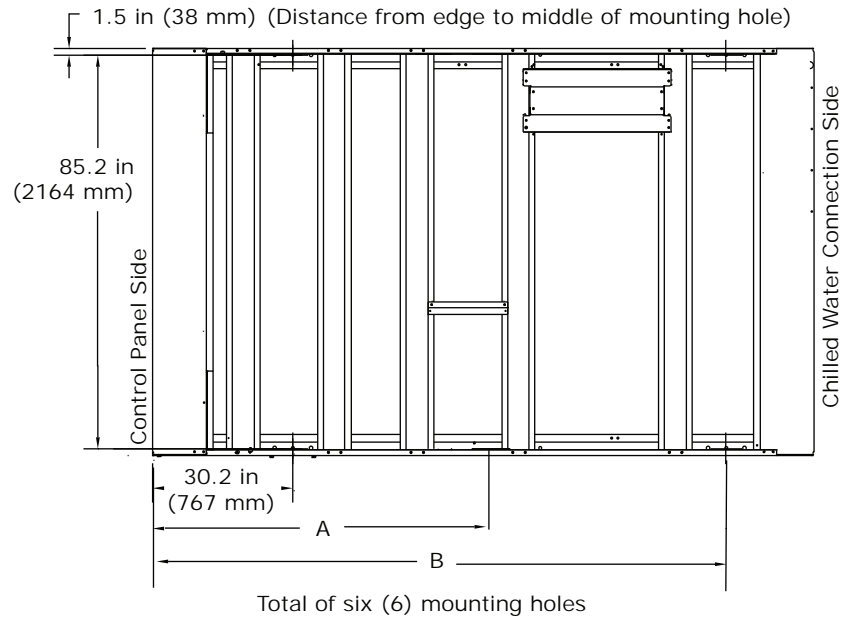
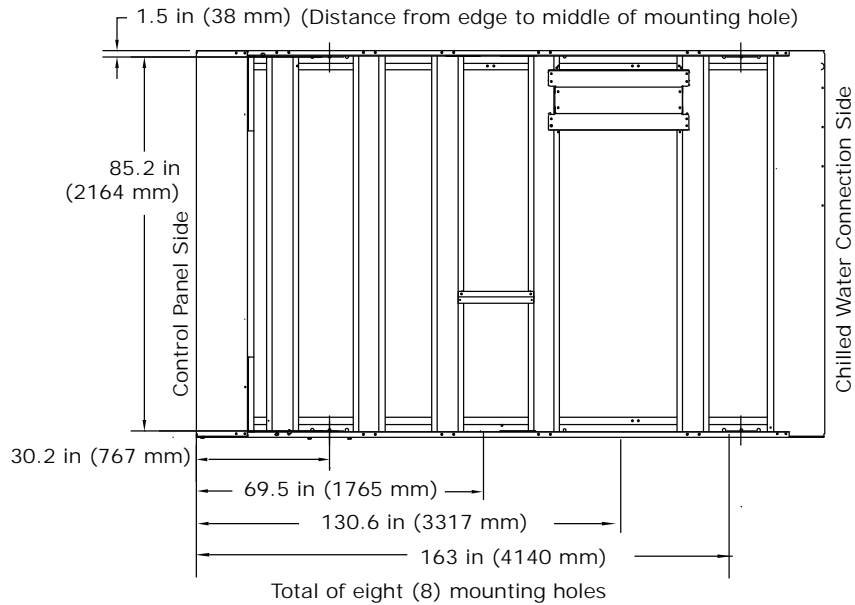

Table 11. Mounting locations, 80 to 120 ton units without wind load option

Unit Size (tons)	A		B	
	in	mm	in	mm
80, 90	83.7	2126	123.9	3147
100, 110, 120	89.2	2266	146.9	3731

Figure 13. Mounting locations, 130 ton



Units with Wind Load Rating

For units with wind load rating (model number digit 17 = D), additional mounting points are required as shown below.

Important: All mounting points in previous section remain the same.

Figure 14. Additional mounting locations for 40 and 52 ton units with wind load option

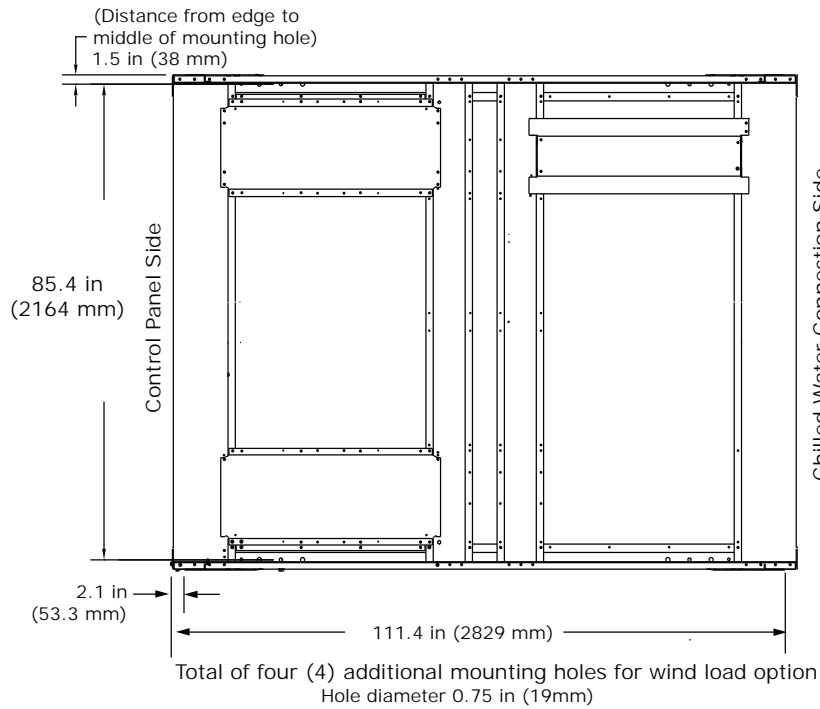
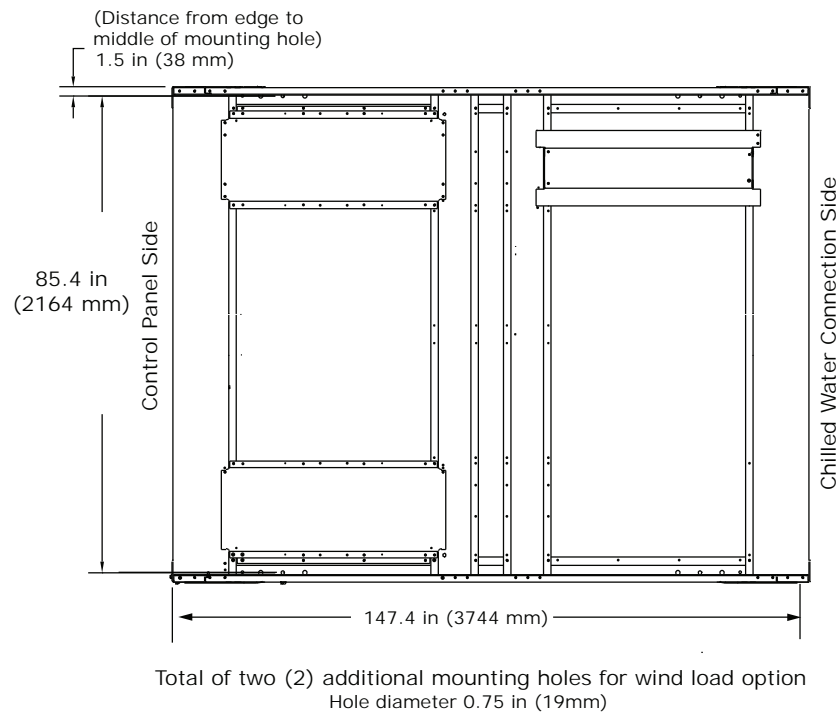
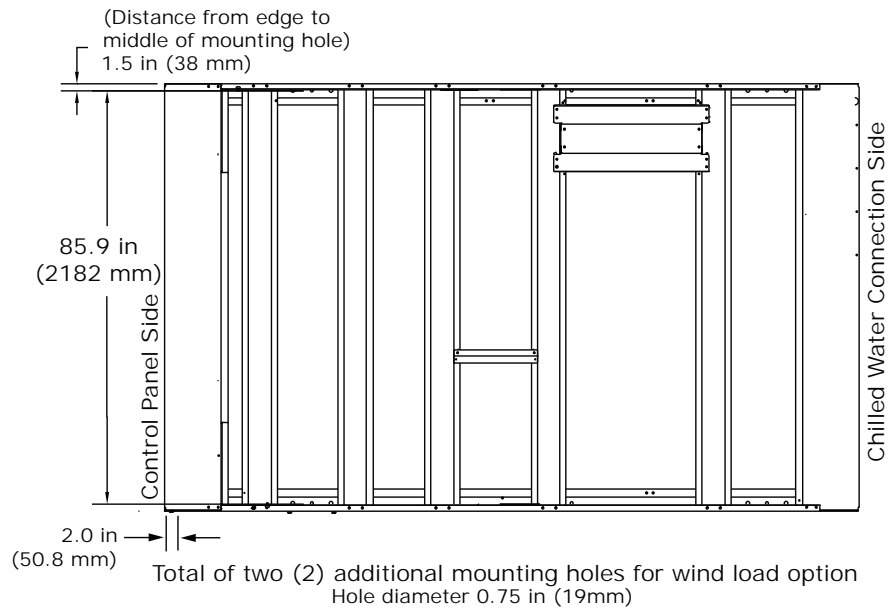

Figure 15. Additional mounting locations for 60 and 70 ton units with wind load option



Dimensions and Weights

Figure 16. Additional mounting locations for 80 to 130 ton units with wind load option



Weights

Base Units

Round Tube and Plate Fin Condenser Coils

Notes:

- Base unit weights include aluminum fins, refrigerant charge, elastomeric isolators, circuit breakers and louvers.
- For units with microchannel condenser coils, see “Microchannel Condenser Coils,” p. 34.
- These weights do NOT include the following options: partial heat recovery, copper fins or seismic isolators. See “Option Weights,” p. 36 for additional weight added by these option selections.

Table 12. Base unit weights, 60 Hz, round tube and plate fin condenser – I-P (lb)

Unit Size (Tons)	Base Unit		Base Unit With Pump Package		Base Unit With Pump Package and Buffer Tank	
	Shipping	Operating	Shipping	Operating	Shipping	Operating
High Efficiency						
20	2185	2208	2726	2814	3252	4491
26	2249	2278	2790	2891	3317	4562
30	2846	2880	3388	3497	3915	5163
35	2878	2920	3420	3546	3947	5204
40	3666	3697	4285	4383	4876	6116
52	3761	3806	4379	4506	4971	6225
60	4978	5033	5814	5986	6406	7695
70	5045	5121	5881	6094	6473	7782
80	5607	5692	6486	6790	7077	8561
90	5859	5961	6738	7075	7329	8830
100	6646	6759	7549	7909	8265	10136
110	6724	6846	7627	8005	8343	10223
120	6762	6884	8018	8396	8733	10614
130	7753	7900	9006	9430	9722	11623
Extra Efficiency						
20	2258	2281	2798	2887	3325	4564
26	2322	2351	2863	2964	3389	4634
30	2945	2979	3487	3596	4014	5262
35	3023	3065	3565	3691	4092	5349
40	3812	3843	4431	4529	5022	6262
52	3959	4004	4578	4705	5169	6423
60	5177	5232	6013	6184	6604	7893
70	5118	5194	5954	6166	6545	7855
110	6724	6846	7627	8005	8343	10223
120	6762	6884	8018	8396	8733	10614

Note: All weights ±3%.



Dimensions and Weights

Table 13. Base unit weights, 60 Hz, round tube and plate fin condenser – SI (kg)

Unit Size (Tons)	Base Unit		Base Unit With Pump Package		Base Unit With Pump Package and Buffer Tank	
	Shipping	Operating	Shipping	Operating	Shipping	Operating
High Efficiency						
20	991	1002	1236	1277	1475	2037
26	1020	1034	1265	1311	1504	2069
30	1291	1306	1537	1586	1776	2342
35	1305	1325	1551	1608	1790	2360
40	1663	1677	1944	1988	2212	2774
52	1706	1726	1987	2044	2255	2824
60	2258	2283	2637	2715	2906	3490
70	2289	2323	2668	2764	2936	3530
80	2543	2582	2942	3080	3210	3883
90	2658	2704	3056	3209	3324	4005
100	3015	3066	3424	3587	3749	4598
110	3050	3105	3460	3631	3784	4637
120	3067	3122	3637	3808	3961	4814
130	3517	3583	4085	4277	4410	5272
Extra Efficiency						
20	1024	1035	1269	1310	1508	2070
26	1053	1066	1298	1344	1537	2102
30	1336	1351	1582	1631	1821	2387
35	1371	1390	1617	1674	1856	2426
40	1729	1743	2010	2054	2278	2840
52	1796	1816	2077	2134	2345	2914
60	2348	2373	2727	2805	2996	3580
70	2322	2356	2701	2797	2969	3563
110	3050	3105	3460	3631	3784	4637
120	3067	3122	3637	3808	3961	4814

Note: All weights $\pm 3\%$.

Table 14. Base unit weights, 50 Hz, round tube and plate fin condenser

Unit Size (Tons)	I-P Units (lb)		SI Units (kg)	
	Shipping	Operating	Shipping	Operating
High Efficiency				
20	2187	2210	992	1002
26	2249	2278	1020	1034
30	2846	2880	1291	1306
35	2878	2920	1305	1325
40	3666	3697	1663	1677
52	3761	3806	1706	1726
60	4978	5033	2258	2283
70	5045	5121	2289	2323
80	5607	5692	2543	2582
90	5858	5960	2657	2703
100	6630	6743	3007	3059
110	6713	6835	3045	3100
120	6758	6880	3065	3121
Extra Efficiency				
20	2260	2283	1025	1035
26	2322	2351	1053	1066
30	2945	2979	1336	1351
35	3023	3065	1371	1390
40	3812	3843	1729	1743
52	3959	4004	1796	1816
60	5177	5232	2348	2373
70	5118	5194	2322	2356
110	6713	6835	3045	3100
120	6758	6880	3065	3121

Note: All weights $\pm 3\%$.



Dimensions and Weights

Microchannel Condenser Coils

Notes:

- Base unit weights include refrigerant charge, isolators, circuit breakers and louvers.
- For units with round tube and plate fin condensers, see ["Round Tube and Plate Fin Condenser Coils," p. 31.](#)

Table 15. Base unit weights, 60 Hz, microchannel condenser — I-P (lb)

Unit Size (Tons)	Base Unit		Base Unit With Pump Package		Base Unit With Pump Package and Buffer Tank	
	Shipping	Operating	Shipping	Operating	Shipping	Operating
High Efficiency						
20	1967	1975	2507	2582	3034	4259
26	2030	2046	2571	2659	3098	4329
30	2388	2403	2929	3021	3456	4686
35	2608	2630	3150	3256	3677	4914
40	3307	3314	3926	3999	4517	5732
52	3402	3422	4021	4122	4612	5840
60	4136	4156	4972	5108	5563	6817
70	4579	4616	5415	5589	6006	7278
80	4888	4899	5766	5996	6357	7768
90	5141	5163	6020	6277	6611	8032
100	5816	5838	6719	6988	7434	9215
110	5893	5924	6796	7083	7511	9301
120	5930	5966	7186	7477	7902	9696
130	6722	6757	7976	8287	8691	10480

Note: All weights $\pm 3\%$.

Table 16. Base unit weights, 60 Hz, microchannel condenser — SI (kg)

Unit Size (Tons)	Base Unit		Base Unit With Pump Package		Base Unit With Pump Package and Buffer Tank	
	Shipping	Operating	Shipping	Operating	Shipping	Operating
High Efficiency						
20	892	896	1137	1171	1376	1932
26	921	928	1166	1206	1405	1964
30	1083	1090	1329	1370	1568	2126
35	1183	1193	1429	1477	1668	2229
40	1500	1503	1781	1814	2049	2600
52	1543	1552	1824	1870	2092	2649
60	1876	1885	2255	2317	2523	3092
70	2077	2094	2456	2535	2724	3301
80	2217	2222	2616	2720	2884	3523
90	2332	2342	2731	2847	2999	3643
100	2638	2648	3048	3170	3372	4180
110	2673	2687	3083	3213	3407	4219
120	2690	2706	3260	3392	3584	4398
130	3049	3065	3618	3759	3942	4754

Note: All weights $\pm 3\%$.

Table 17. Base unit weights, 50 Hz, microchannel condenser

Unit Size (Tons)	I-P (lb)		SI (kg)	
	Shipping	Operating	Shipping	Operating
High Efficiency				
20	1967	1978	892	897
26	2030	2046	921	928
30	2388	2403	1083	1090
35	2608	2630	1183	1193
40	3307	3314	1500	1503
52	3402	3422	1543	1552
60	4136	4156	1876	1885
70	4579	4616	2077	2094
80	4888	4899	2217	2222
90	5139	5163	2331	2342
100	5798	5822	2630	2641
110	5882	5913	2668	2682
120	5926	5961	2688	2704

Note: All weights $\pm 3\%$.



Dimensions and Weights

Option Weights

Note: Weights listed below are in addition to base unit weights found in previous section. For total unit weight, add option weights to base unit weight found in "Round Tube and Plate Fin Condenser Coils," p. 31.

Table 18. Option weights, 60 Hz, round tube and plate fin condenser

Unit Size (tons)	I-P Units (lb)				SI Units (kg)			
	Partial Heat Recovery		Copper Fins	Seismic Isolator	Partial Heat Recovery		Copper Fins	Seismic Isolator
Shipping	Operating	Shipping			Operating			
High Efficiency								
20	39	63	258	160	18	28	117	73
26	39	70	258	160	18	32	117	73
30	47	82	359	160	21	37	163	73
35	47	91	359	160	21	41	163	73
40	94	128	516	160	43	58	234	73
52	94	143	516	160	43	65	234	73
60	111	170	719	240	50	77	326	109
70	111	191	719	240	50	87	326	109
80	170	260	1270	240	77	118	576	109
90	170	279	1270	240	77	126	576	109
100	178	298	1512	240	81	135	686	109
110	178	307	1512	240	81	139	686	109
120	178	310	1512	240	81	140	686	109
130	178	335	1889	320	81	152	857	145
Extra Efficiency								
20	39	63	258	-	18	28	117	-
26	39	70	258	-	18	32	117	-
30	47	82	360	-	21	37	163	-
35	47	91	360	-	21	41	163	-
40	94	128	516	-	43	58	234	-
52	94	143	516	-	43	65	234	-
60	111	170	720	-	50	77	326	-
70	111	191	720	-	50	87	326	-
110	178	307	1512	-	81	139	686	-
120	178	310	1512	-	81	140	686	-

Note: All weights $\pm 3\%$.

Table 19. Option weights, 50 Hz, round tube and plate fin condenser

Unit Size (tons)	I-P Units (lb)				SI Units (kg)			
	Partial Heat Recovery		Copper Fins	Seismic Isolator	Partial Heat Recovery		Copper Fins	Seismic Isolator
Shipping	Operating	Shipping			Operating			
High Efficiency								
20	40	24	258	160	18	11	117	73
26	40	31	258	160	18	14	117	73
30	46	35	359	160	21	16	163	73
35	46	44	359	160	21	20	163	73
40	95	33	516	160	43	15	234	73
52	95	49	516	160	43	20	234	73
60	110	60	719	240	50	27	326	109
70	110	79	719	240	50	36	326	109
80	170	90	1270	240	77	41	576	109
90	170	108	1270	240	77	49	576	109
100	179	119	1512	240	81	54	686	109
110	179	130	1512	240	81	59	686	109
120	179	130	1512	240	81	59	686	109
Extra Efficiency								
20	40	24	258	-	18	11	117	-
26	40	31	258	-	18	14	117	-
30	46	35	359	-	21	16	163	-
35	46	44	359	-	21	20	163	-
40	95	33	516	-	43	15	234	-
52	95	49	516	-	43	22	234	-
60	110	60	719	-	50	27	326	-
70	110	79	719	-	50	36	326	-
110	179	130	1512	-	81	59	686	-
120	179	130	1512	-	81	59	686	-

Note: All weights $\pm 3\%$.



Installation - Mechanical

Location Requirements

Sound Considerations

- Refer to *Trane Engineering Bulletin Chiller Sound Ratings and Installation Guide* CG-PRB010-EN for sound consideration applications.
- Locate the unit away from sound-sensitive areas.
- Install the optional elastomeric isolators under the unit. See “Unit Isolation and Leveling,” p. 45.
- Chilled water piping should not be supported by chiller frame.
- Install rubber vibration isolators in all water piping.
- Seal all wall penetrations.

Note: Consult an acoustical engineer for critical applications.

Wind Load Considerations

For units with wind load certification and architectural louvered panels (model number digit 17 = D), refer to Technical Evaluation Report listed below for necessary storm preparation.

Unit Size (tons)	TER
40 to 70	TER-15-2904V
80 to 130	TER-15-2904W

Foundation

Provide rigid, non-warping mounting pads or a concrete foundation of sufficient strength and mass to support the applicable operating weight (i.e., including completed piping, and full operating charges of refrigerant, oil and water). Refer to the chapter on “Unit Dimensions/Weights” for unit operating weights. Once in place, the unit must be level within 1/4” (6.4 mm) over its length and width. The Trane Company is not responsible for equipment problems resulting from an improperly designed or constructed foundation.

Clearances

Provide enough space around the unit to allow the installation and maintenance personnel unrestricted access to all service points. Refer to submittal drawings for the unit dimensions, to provide sufficient clearance for the opening of control panel doors and unit service. See “Service Clearances,” p. 25 for minimum clearances. In all cases, local codes which require additional clearances will take precedence over these recommendations.

Rigging

See “Weights,” p. 31 for typical unit lifting weights. Refer to the rigging label attached to the unit for further details.

Lifting Procedure

⚠ WARNING

Heavy Objects!

Failure to follow instructions below or properly lift unit could result in unit dropping and possibly crushing operator/technician which could result in death or serious injury, and equipment or property-only damage. Ensure that all the lifting equipment used is properly rated for the weight of the unit being lifted. Each of the cables (chains or slings), hooks, and shackles used to lift the unit must be capable of supporting the entire weight of the unit. Lifting cables (chains or slings) may not be of the same length. Adjust as necessary for even unit lift.

⚠ WARNING

Improper Unit Lift!

Failure to properly lift unit could result in unit dropping and possibly crushing operator/technician which could result in death or serious injury, and equipment or property-only damage. Test lift unit approximately 24 inches to verify proper center of gravity lift point. To avoid dropping of unit, reposition lifting point if unit is not level.

NOTICE:

Equipment Damage!

To prevent damage to unit, do not fork lift or allow lifting cables to contact unit during lift.

Lifting using either a single spreader bar or an H-type spreader is acceptable. Attach chains or cables to lifting beam. Lifting beam crossbars **MUST** be positioned so lifting cables do not contact the sides of the unit.

Important: The center of gravity (CG) is never at the midpoint of the base rail lifting strap holes. A level unit lift is required for a safe lift and to prevent unit damage.

Lifting a unit with equal length straps will NOT produce a level unit during the lift because the CG will not be at the midpoint between the base lifting holes. The following adjustments must be made to produce a level lift:

- Single spreader bar lifting method
 - If the unit CG is closer to the control panel, the straps on the control panel side of the spreader bar must be adjusted to be shorter than those on the opposite side of the spreader bar, allowing the spreader bar to move toward the control panel and over the unit CG. Several adjustments of the strap length may be required to produce a level unit during lift.

- H-type spreader bar lifting method
 - If the straps from the H bar to the unit base are the same length, the crane lifting point on the center web of the H bar must be adjusted to produce a level unit lift. See [Figure 17, p. 39](#) for illustration.

Figure 17. H-type spreader bar adjustment for level unit lift

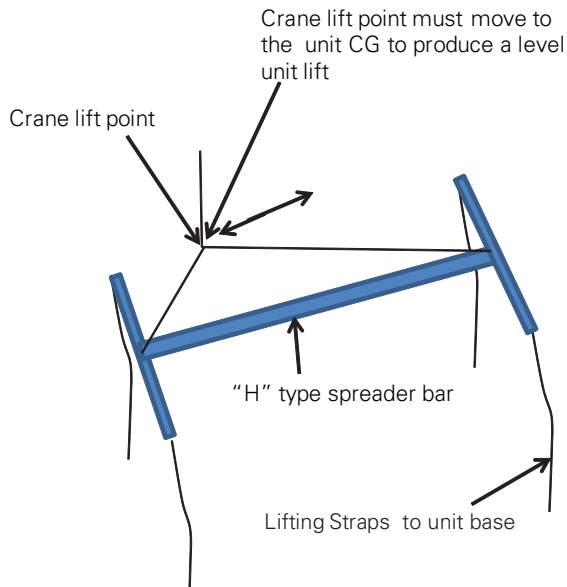

Figure 18. CGAM slant 20 to 35 ton unit rigging

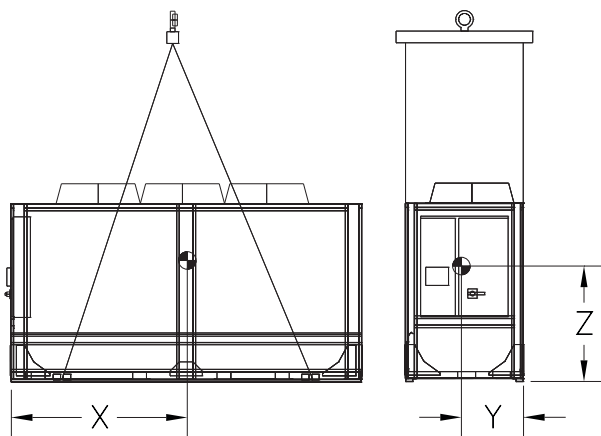

Figure 19. CGAM V 40 to 70 ton unit rigging

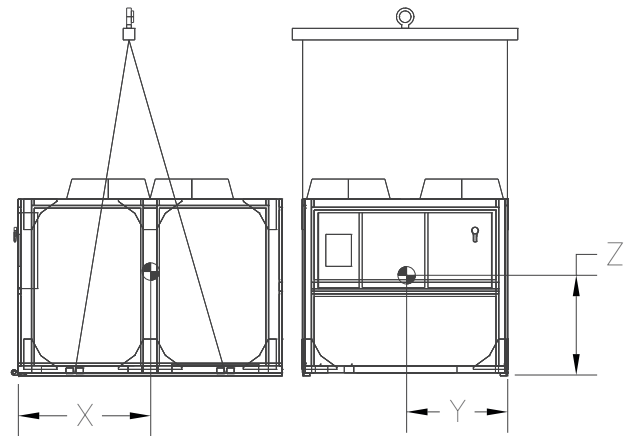
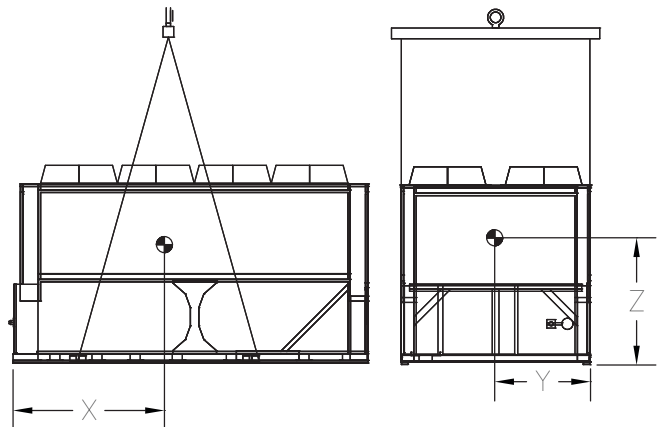

Figure 20. CGAM W 80 to 130 ton unit rigging





Installation - Mechanical

Center of Gravity

Note: Center of gravity values do not change if wind load option is selected.

Units with Round Tube and Plate Fin (RTPF) Condenser

Table 20. Center of gravity (in) — RTPF condenser, 60 Hz, high efficiency

Unit (tons)	Aluminum fins									Copper fins								
	Base Unit			With Pump Package			With Pump Pkg, Buffer Tank			Base Unit			With Pump Package			With Pump Pkg, Buffer Tank		
	X	Y	Z	X	Y	Z	X	Y	Z	X	Y	Z	X	Y	Z	X	Y	Z
Units without Partial Heat Recovery																		
20	50	24	38	56	23	34	67	23	35	51	24	39	57	23	35	67	23	35
26	49	24	38	56	23	33	67	23	34	51	24	39	57	23	34	67	23	35
30	65	24	39	73	23	35	86	23	36	67	24	40	74	23	36	85	23	37
35	63	23	38	72	22	34	84	23	35	65	23	39	73	23	35	83	23	36
40	48	45	37	53	42	34	62	43	35	50	45	38	53	42	35	61	43	36
52	49	45	37	53	43	34	61	43	34	50	45	38	53	43	35	61	43	35
60	64	45	39	69	43	36	78	43	36	65	45	40	69	43	37	78	43	37
70	62	46	37	67	43	35	75	43	35	63	45	38	67	43	36	75	43	36
80	59	47	38	68	46	37	68	46	35	62	46	42	69	46	41	68	46	39
90	59	47	37	68	46	36	67	46	34	61	46	41	68	46	40	68	46	38
100	72	47	38	82	46	37	81	46	35	75	46	42	82	46	41	81	46	39
110	72	47	38	81	46	37	80	46	35	74	46	42	81	46	41	81	46	39
120	72	47	38	83	46	36	82	46	35	74	46	42	83	46	40	83	46	38
130	86	47	39	100	46	38	100	46	36	89	46	44	100	46	42	101	46	40
Units with Partial Heat Recovery																		
20	50	24	38	57	23	33	67	23	34	52	24	39	57	23	35	67	24	35
26	50	24	37	56	23	33	67	23	34	51	24	38	57	23	34	67	23	35
30	65	24	39	73	23	35	86	24	35	67	24	40	74	23	36	85	24	36
35	63	23	37	71	23	34	83	23	34	65	23	38	73	23	35	83	23	35
40	50	45	37	54	42	34	62	43	35	51	45	38	54	43	35	62	43	36
52	50	45	37	54	43	34	62	43	35	51	45	38	54	43	35	62	43	35
60	65	45	40	70	43	36	79	43	37	67	45	40	71	43	37	79	43	37
70	63	46	38	68	43	35	76	43	35	65	45	38	69	43	36	76	43	36
80	58	47	38	67	46	37	67	46	35	61	46	42	68	46	41	67	46	39
90	58	47	37	67	46	36	66	46	35	60	46	41	67	46	40	67	46	39
100	71	47	38	80	46	37	79	46	35	73	46	42	81	46	41	80	46	39
110	71	47	38	80	46	37	79	46	35	73	46	42	80	46	41	80	46	39
120	70	47	38	82	46	36	81	46	35	73	46	42	82	46	40	82	46	39
130	84	46	39	98	46	38	99	46	36	88	46	44	99	46	42	100	46	40

Table 21. Center of gravity (in) — RTPF condenser, 60 Hz, extra efficiency

Unit (tons)	Aluminum fins									Copper fins								
	Base Unit			With Pump Package			With Pump Pkg, Buffer Tank			Base Unit			With Pump Package			With Pump Pkg, Buffer Tank		
	X	Y	Z	X	Y	Z	X	Y	Z	X	Y	Z	X	Y	Z	X	Y	Z
Units without Partial Heat Recovery																		
20	50	24	39	57	23	34	67	23	35	52	24	40	58	23	36	67	23	36
26	50	24	38	56	23	34	67	23	35	52	24	39	57	23	35	67	23	36
30	65	24	39	74	23	35	86	23	36	68	24	41	75	23	37	85	23	37
35	64	23	38	72	23	34	83	23	35	67	23	39	73	23	36	83	23	36
40	49	45	37	53	42	34	61	43	35	50	45	38	54	43	36	61	43	36
52	49	45	37	53	43	34	61	43	35	50	45	38	54	43	35	61	43	36
60	64	45	40	69	43	36	78	43	37	66	45	40	70	43	38	77	43	38
70	62	45	38	67	43	35	75	43	35	64	45	39	68	43	36	75	44	36
110	72	47	38	81	46	37	80	46	35	74	46	42	81	46	41	81	46	39
120	72	47	38	83	46	36	82	46	35	74	46	42	83	46	40	83	46	38
Units with Partial Heat Recovery																		
20	51	24	38	57	23	34	67	23	35	53	24	39	58	23	35	67	24	36
26	50	24	38	56	23	33	67	23	34	52	24	39	57	23	35	67	23	35
30	65	24	39	74	23	35	86	24	36	68	24	40	75	23	37	85	24	37
35	64	23	37	72	23	34	83	23	35	67	24	39	73	23	36	83	23	36
40	50	45	38	54	42	35	62	43	35	51	45	39	55	43	36	62	43	36
52	50	45	37	54	43	34	62	43	35	51	45	38	55	43	36	61	43	36
60	66	45	40	70	43	37	79	43	37	68	45	40	71	43	38	78	43	38
70	64	45	38	68	43	35	76	43	35	66	45	39	69	43	36	76	44	37
110	71	47	38	80	46	37	79	46	35	73	46	42	80	46	41	80	46	39
120	70	47	38	82	46	36	81	46	35	73	46	42	82	46	40	82	46	39



Installation - Mechanical

Table 22. Center of gravity (in) – RTPF condenser, 50 Hz, high efficiency

Unit (tons)	Aluminum fins									Copper fins								
	Base Unit			With Pump Package			With Pump Pkg, Buffer Tank			Base Unit			With Pump Package			With Pump Pkg, Buffer Tank		
	X	Y	Z	X	Y	Z	X	Y	Z	X	Y	Z	X	Y	Z	X	Y	Z
Units without Partial Heat Recovery																		
20	49	24	38	54	23	35	66	23	35	51	24	39	55	23	36	66	23	36
26	49	24	38	54	23	34	66	23	35	51	24	39	55	23	35	66	23	36
30	65	24	39	71	23	36	84	23	36	67	24	40	72	23	37	84	24	37
35	63	23	38	69	23	35	82	23	35	65	23	39	71	23	36	82	23	36
40	48	45	37	52	43	35	61	43	35	50	45	38	52	43	36	60	43	36
52	49	45	37	52	43	34	61	43	35	50	45	38	53	43	35	60	43	36
60	64	45	39	69	43	36	78	43	36	65	45	40	70	43	37	78	43	37
70	62	46	37	67	43	34	76	43	35	63	45	38	68	43	35	76	43	36
80	59	47	38	68	46	37	67	46	35	62	46	42	69	46	41	68	46	39
90	59	47	37	67	46	36	67	46	35	61	46	41	68	46	40	67	46	38
100	72	47	38	81	46	37	80	46	35	74	46	42	81	46	41	80	46	39
110	72	47	38	81	46	37	80	46	35	74	46	42	81	46	41	80	46	39
120	72	47	38	82	46	36	81	46	35	74	46	42	82	46	40	81	46	39
Units with Partial Heat Recovery																		
20	49	24	38	54	23	34	66	24	35	51	24	39	55	23	35	66	24	36
26	50	24	37	54	23	34	66	23	35	51	24	38	55	23	35	66	24	36
30	65	24	39	71	23	36	84	24	36	67	24	40	72	24	37	84	24	37
35	63	23	37	69	23	34	82	23	35	65	23	38	71	23	35	82	23	36
40	50	45	37	53	43	35	62	43	35	51	45	38	53	43	36	61	43	36
52	50	45	37	53	43	35	62	43	35	51	45	38	54	43	35	61	43	36
60	65	45	40	71	43	36	80	43	36	67	45	40	71	43	37	79	43	37
70	63	46	38	69	43	35	77	43	35	65	45	38	69	43	35	77	43	36
80	58	47	38	67	46	37	66	46	35	61	46	42	68	46	41	67	46	39
90	58	47	37	66	46	36	66	46	35	60	46	41	67	46	40	67	46	39
100	70	47	38	79	46	37	79	46	36	73	46	42	80	46	41	79	46	39
110	70	47	38	79	46	37	79	46	35	73	46	42	80	46	41	79	46	39
120	70	47	38	80	46	37	80	46	35	73	46	42	81	46	40	80	46	39

Table 23. Center of gravity (in) – RTPF condenser, 50 Hz, extra efficiency

Unit (tons)	Aluminum fins									Copper fins								
	Base Unit			With Pump Package			With Pump Pkg, Buffer Tank			Base Unit			With Pump Package			With Pump Pkg, Buffer Tank		
	X	Y	Z	X	Y	Z	X	Y	Z	X	Y	Z	X	Y	Z	X	Y	Z
Units without Partial Heat Recovery																		
20	50	24	39	57	23	34	67	23	35	52	24	40	58	23	36	67	23	36
26	50	24	38	56	23	34	67	23	35	52	24	39	57	23	35	67	23	36
30	65	24	39	74	23	35	86	23	36	68	24	41	75	23	37	85	23	37
35	64	23	38	72	23	34	83	23	35	67	23	39	73	23	36	83	23	36
40	49	45	37	53	42	34	61	43	35	50	45	38	54	43	36	61	43	36
52	49	45	37	53	43	34	61	43	35	50	45	38	54	43	35	61	43	36
60	64	45	40	69	43	36	78	43	37	66	45	40	70	43	38	77	43	38
70	62	45	38	67	43	35	75	43	35	64	45	39	68	43	36	75	44	36
110	72	47	38	81	46	37	80	46	35	74	46	42	81	46	41	80	46	39
120	72	47	38	82	46	36	81	46	35	74	46	42	82	46	40	81	46	39
Units with Partial Heat Recovery																		
20	51	24	38	57	23	34	67	23	35	53	24	39	58	23	35	67	24	36
26	50	24	38	56	23	33	67	23	34	52	24	39	57	23	35	67	23	35
30	65	24	39	74	23	35	86	24	36	68	24	40	75	23	37	85	24	37
35	64	23	37	72	23	34	83	23	35	67	24	39	73	23	36	83	23	36
40	50	45	38	54	42	35	62	43	35	51	45	39	55	43	36	62	43	36
52	50	45	37	54	43	34	62	43	35	51	45	38	55	43	36	61	43	36
60	66	45	40	70	43	37	79	43	37	68	45	40	71	43	38	78	43	38
70	64	45	38	68	43	35	76	43	35	66	45	39	69	43	36	76	44	37
110	70	47	38	79	46	37	79	46	35	73	46	42	80	46	41	79	46	39
120	70	47	38	80	46	37	80	46	35	73	46	42	81	46	40	80	46	39



Installation - Mechanical

Units with Microchannel Condenser

Table 24. Center of gravity (in) – microchannel condenser, high efficiency

Unit (tons)	60 Hz Units									50 Hz Units		
	Base Unit			With Pump Package			With Pump Pkg, Buffer Tank			Base Unit		
	X	Y	Z	X	Y	Z	X	Y	Z	X	Y	Z
High Efficiency Units												
20	49	38	24	56	33	23	68	34	23	49	38	24
26	49	37	24	56	33	23	67	34	23	49	37	24
30	64	39	24	73	34	23	86	35	23	64	39	24
35	62	37	23	71	33	22	84	34	23	62	37	23
40	47	37	45	52	33	42	62	34	42	47	37	45
52	48	36	45	52	33	43	62	34	43	48	36	45
60	62	39	45	68	35	43	78	36	43	62	39	45
70	60	37	46	66	34	43	75	34	43	60	37	46
80	58	35	47	68	34	47	67	32	46	58	35	47
90	58	34	47	67	33	47	67	32	47	58	34	47
100	71	35	47	82	34	47	81	33	47	71	35	47
110	71	35	47	81	34	47	80	33	47	71	35	47
120	70	35	47	84	33	47	83	32	47	70	35	47
130	84	36	47	99	35	46	100	33	46	-	-	-

Unit Isolation and Leveling

General

Construct an isolated concrete pad for the unit or provide concrete footings at each of the unit mounting points. Mount the unit directly to the concrete pads or footings.

Level the unit using the base rail as a reference. The unit must be level within 1/4" over the entire length (end-to-end as well as side-to-side). Use shims as necessary to level the unit.

Isolator Options

Elastomeric Isolators

Install the optional neoprene isolators at each mounting location. Isolators are identified by part number and color.

1. Secure the isolators to the mounting surface, using the mounting slots in the isolator base plate, as shown in [Figure 21](#). Do not fully tighten the isolator mounting bolts at this time.
2. Align the mounting holes in the base of the unit, with the threaded positioning pins on the top of isolators.
3. Lower the unit on to the isolators and secure the isolator to the unit with a nut. Level the unit carefully. Refer to "Leveling". Fully tighten the isolator mounting bolts.

Figure 21. CGAM elastomeric isolator

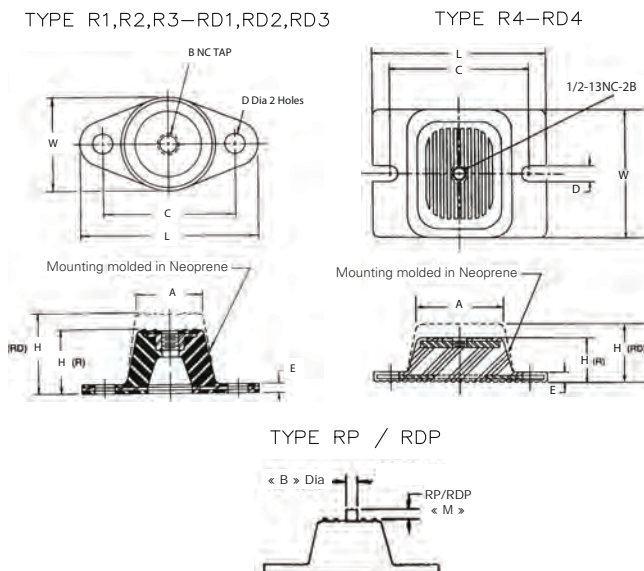

Table 25. CGAM elastomeric rated isolator

Ext	Max Load (lbs)	Color	Maximum Deflection (in)							
Ext	A	B	C	D	E	H	L	M	W	
57	250	Black	0.50							RDP3-WR
58	525	Red	0.50							RDP4-WR
59	750	Green	0.50							RDP4-WR
60	1100	Gray	0.50							RDP4-WR
61	1500	Brown	0.50							RDP4-WR
62	2250	Red	0.50							RDP4-WR
63	3000	Green	0.50							RDP4-WR
64	4000	Gray	0.50							RDP4-WR

Ext	A	B	C	D	E	H	L	M	W
57									
58	2.5	.5	4.12	.56	.25	2.88	5.5	1.13	3.38
59									
60									
61									
62	3.0	.5	5.0	.56	.38	2.75	6.25	1.60 ± .25	4.63
63									
64									

Seismically Rated Isolators

Seismically rated isolators are required for OSHPD and IBC seismically rated units.

Seismic Isolator Specifications

Isolators are identified by part number and color. See [Table 26](#). For dimensions, see [Figure 22](#) and [Figure 23](#), p. 46. Install the optional seismically rated isolators at each mounting location.

Table 26. CGAM seismically rated isolator

Model	Rated Load (lbs)	Rated Deflection (in)	Spring Rate (lbs/in)	Color Code
MSSH-1E-530N	530	1.17	453	Black/Dk Blue
MSSH-1E-825N	825	1.07	769	Red/ Dk Blue
MSSH-1E-1000	1000	1.00	1000	Tan
M2SS-1E-800	800	1.32	606	Black
M2SS-1E-1060N	1060	1.17	906	Black/Dk Blue
M2SS-1E-1300	1300	1.05	1240	Red
M2SS-1E-1650N	1650	1.07	1538	Red/Dk Blue
M2SS-1E-2000	2000	1.00	2000	Tan
M2SS-1E-2400N	2400	1.04	2300	Tan/Dk Blue

Figure 22. MSSH seismically rated isolator

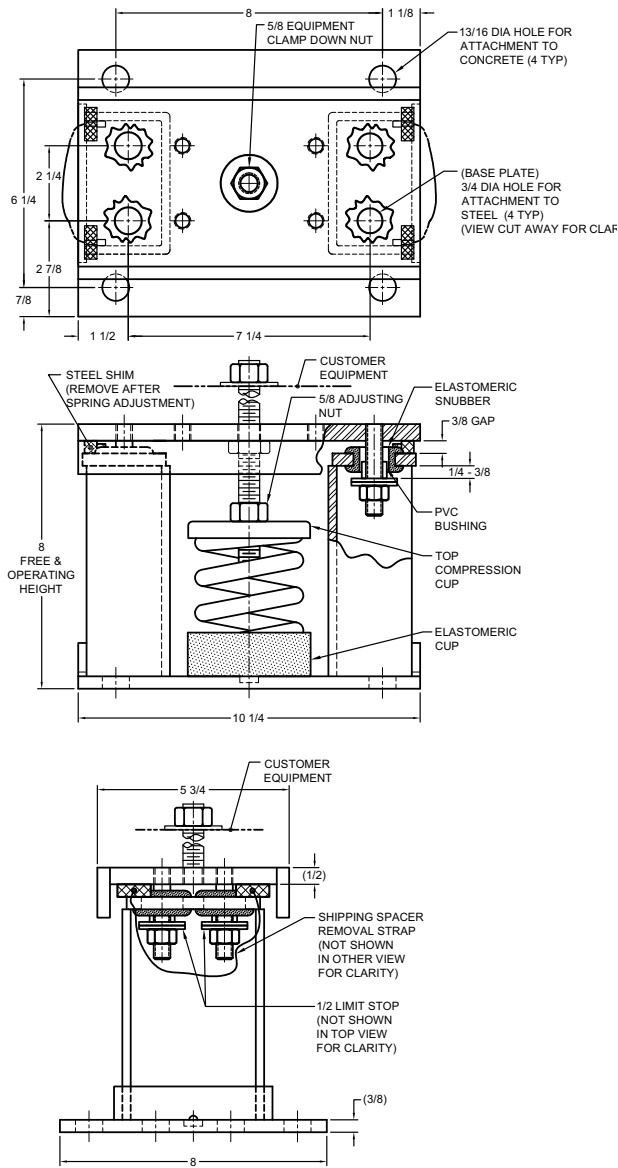
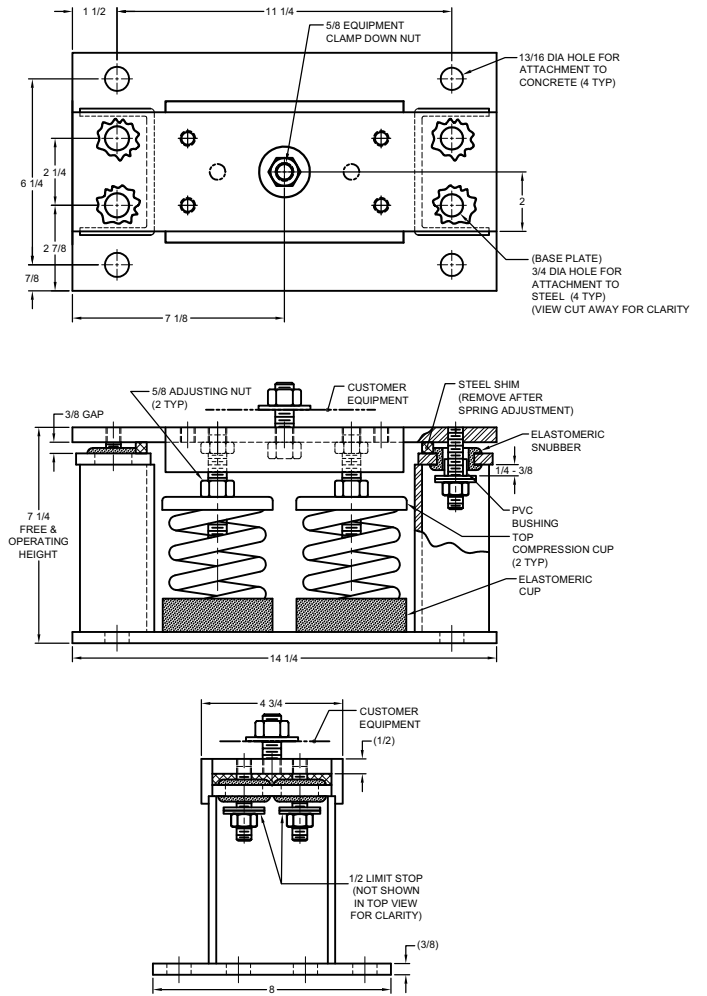

Figure 23. M2SS seismically rated isolator



Installation of Seismically Rated Isolators

See Figure 24 and Figure 25, p. 47 for reference.

Figure 24. MSSH seismic isolator installation reference

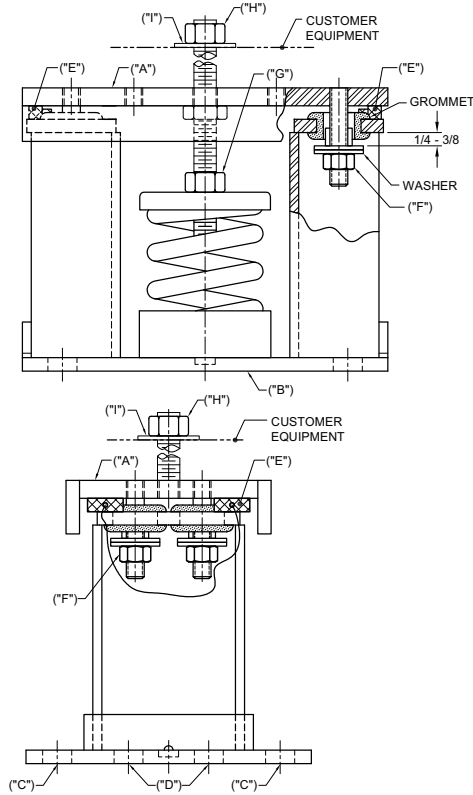
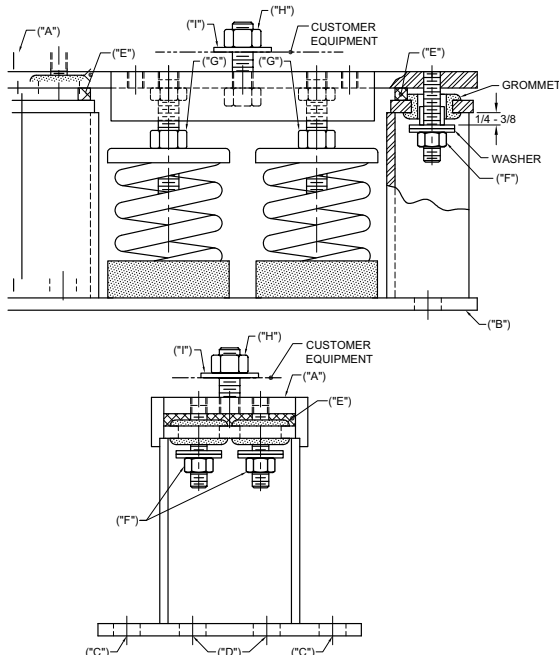

Figure 25. M2SS seismic isolator installation reference



1. Set isolators on mounting surface, ensuring that all isolator centerlines match the submittal drawing. All isolator base plates (B) must be installed on a level surface. Shim or grout as required, leveling all isolator or base plates at the same elevation.
2. Anchor all isolators to the surface using thru holes (C) for concrete or (D) for steel as require. Welding to steel is permitted providing the weld achieves the required strength.
3. Remove clamp down nut (H) and washer (I). Isolators are shipped with (2) removable spacer shims (E) between the top plate and the housing.

Important: These shims *MUST* be in place when the equipment is positioned over the isolators.

4. With all shims (E) in place, place the equipment onto the top plate (A) of the isolators.
5. Bolt equipment securely to the isolators using doubler plate (included in isolator kit), washer (I) and nut (H) as shown in Figure 26, p. 47.

Figure 26. Seismic isolator installation detail

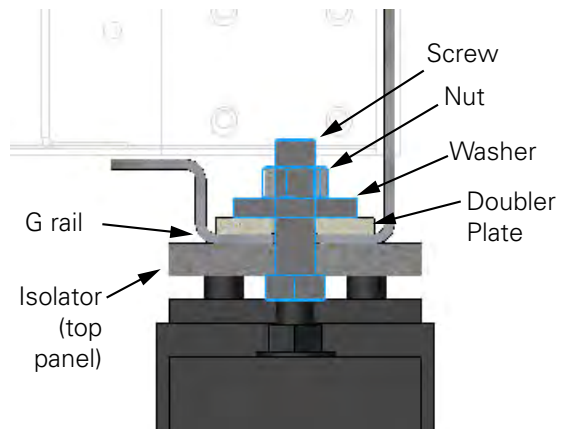

Important: The following adjustment process can only begin after the equipment or machine is at its full operating weight.

6. Back off each of the (2) or (4) limit stop locknuts (F) per isolator 1/4-3/8".
7. Adjust each isolator in sequence by turning adjusting nut(s) (G) one full clockwise turn at a time. Repeat this procedure on all isolators, one at a time. check the limit stop locknuts (F) periodically to ensure that clearance between the washer and rubber grommet is maintained. Stop adjustment of an isolator only when the top plate (A) has risen just above the shim (E).
8. Remove all spacer shims (E).
9. Fine adjust isolators to level equipment.
10. Adjust all limit stop locknuts (F) per isolator to obtain 3/8" gap. the limit stop nuts must be kept at this 3/8" gap to ensure uniform bolt loading during uplift.

Elastomeric Pads

Elastomeric pads are required for units with wind load rating option (model number digit 17 = D).

See “Units with Wind Load Option,” p. 64 for information on quantities required and mounting point identification.

Elastomeric pads ship inside the unit control panel. They are provided with an isolation washer and 3/4” free hole in the center of the plate.

Figure 27. Isolation pad – installed

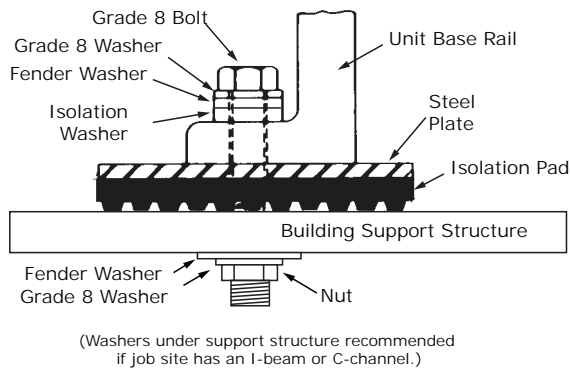

Table 27. Seismically rated elastomeric isolation pad

Model	Max Load	Dimension (in)		
		Length	Width	Height
B-36	2520	6	6	.625

Isolator Selection and Placement

Units without Wind Load Option

Notes:

- Information in this section is applicable to units with elastomeric or seismic isolator options.
- For units with wind load rating option (model number digit model number digit 17 = D), see “Units with Wind Load Option,” p. 64.
- See “Mounting Locations,” p. 26 for mounting point locations dimensions.

Figure 28. Mounting point identification, units without wind load option

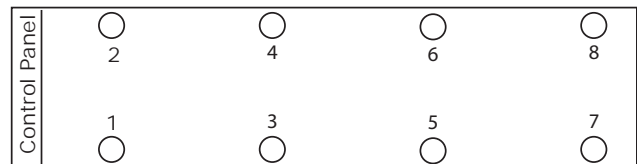
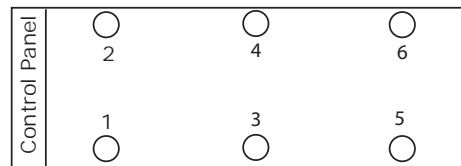
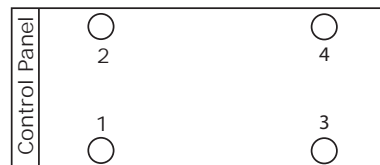

Isolator Selection
Non-Seismic Units
Table 28. Elastomeric isolator selections — base unit (with or without partial heat recovery)

Unit Size (tons)	Location							
	1	2	3	4	5	6	7	8
20, 26	RDP-3	RDP-3	RDP-3	RDP-3	-	-	-	-
	Grey 60	Grey 60	Grey 60	Grey 60				
30, 35	RDP-4	RDP-4	RDP-3	RDP-3	-	-	-	-
	Brown 61	Brown 61	Grey 60	Grey 60				
40, 52	RDP-4	RDP-4	RDP-4	RDP-4	-	-	-	-
	Red 62	Red 62	Red 62	Red 62				
60, 70	RDP-4	RDP-4	RDP-3	RDP-4	RDP-3	RDP-3	-	-
	Red 62	Red 62	Gray 60	Brown 61	Gray 60	Gray 60		
80 to 90	RDP-4	RDP-4	RDP-4	RDP-4	RDP-3	RDP-3	-	-
	Red 62	Green 63	Red 62	Red 62	Gray 60	Gray 60		
100 to 120	RDP-4	RDP-4	RDP-4	RDP-4	RDP-3	RDP-3	-	-
	Red 62	Green 63	Red 62	Red 62	Gray 60	Gray 60		
130	RDP-4	RDP-4	RDP-4	RDP-4	RDP-4	RDP-4	RDP-3	RDP-3
	Red 62	Red 62	Red 62	Red 62	Brown 61	Brown 61	Grey 60	Grey 60

Table 29. Elastomeric isolator selections — with pump package (with or without partial heat recovery)

Unit Size (tons)	Location							
	1	2	3	4	5	6	7	8
20, 26	RDP-4	RDP-3	RDP-3	RDP-3	-	-	-	-
	Brown 61	Grey 60	Grey 60	Grey 60				
30, 35	RDP-4	RDP-4	RDP-4	RDP-4	-	-	-	-
	Brown 61	Brown 61	Brown 61	Brown 61				
40, 52	RDP-4	RDP-4	RDP-4	RDP-4	-	-	-	-
	Red 62	Red 62	Red 62	Red 62				
60, 70	RDP-4	RDP-4	RDP-4	RDP-4	RDP-4	RDP-4	-	-
	Red 62	Red 62	Red 62	Red 62	Red 62	Red 62		
80 to 90	RDP-4	RDP-4	RDP-4	RDP-4	RDP-3	RDP-3	-	-
	Red 62	Red 62	Red 62	Red 62	Grey 60	Grey 60		
100 to 120	RDP-4	RDP-4	RDP-4	RDP-4	RDP-4	RDP-4	-	-
	Green 63	Green 63	Green 63	Green 63	Red 62	Red 62		
130	RDP-4	RDP-4	RDP-4	RDP-4	RDP-4	RDP-4	RDP-4	RDP-4
	Red 62	Red 62	Red 62	Red 62	Red 62	Red 62	Red 62	Red 62

Table 30. Elastomeric isolator selections — with pump package and buffer tank option (with or without partial heat recovery)

Unit Size (tons)	Location							
	1	2	3	4	5	6	7	8
20, 26	RDP-3	RDP-3	RDP-4	RDP-4	-	-	-	-
	Grey 60	Grey 60	Green 63	Green 63				
30, 35	RDP-3	RDP-3	RDP-4	RDP-4	-	-	-	-
	Grey 60	Grey 60	Green 63	Green 63				
40, 52	RDP-4	RDP-4	RDP-4	RDP-4	-	-	-	-
	Brown 61	Brown 61	Grey 64	Grey 64				
60, 70	RDP-4	RDP-4	RDP-4	RDP-4	RDP-4	RDP-4	-	-
	Brown 61	Brown 61	Green 63	Green 63	Green 63	Green 63		
80 to 90	RDP-4	RDP-4	RDP-4	RDP-4	RDP-4	RDP-4	-	-
	Green 63	Green 63	Red 62	Red 62	Brown 61	Brown 61		
100 to 120	RDP-4	RDP-4	RDP-4	RDP-4	RDP-4	RDP-4	-	-
	Grey 64	Grey 64	Green 63	Green 63	Red 62	Red 62		
130	RDP-4	RDP-4	RDP-4	RDP-4	RDP-4	RDP-4	RDP-4	RDP-4
	Green 63	Green 63	Green 63	Green 63	Green 63	Green 63	Green 63	Green 63



Installation - Mechanical

Seismic Units

Table 31. Seismically rated isolator locations

Unit Size (ton)	Locations							
	1	2	3	4	5	6	7	8
20	MSSH-1E-825N Red/Dk Blue	MSSH-1E-825N Red/Dk Blue	MSSH-1E-530N Black/Dk Blue	MSSH-1E-530N Black/Dk Blue	-	-	-	-
26	MSSH-1E-1000 Tan	MSSH-1E-825N Red/Dk Blue	MSSH-1E-530N Black/Dk Blue	MSSH-1E-530N Black/Dk Blue	-	-	-	-
30	M2SS-1E-1300 Red	M2SS-1E-1060N Black/Dk Blue	M2SS-1E-800 Black	M2SS-1E-800 Black	-	-	-	-
35	M2SS-1E-1300 Red	M2SS-1E-1060N Black/Dk Blue	M2SS-1E-800 Black	M2SS-1E-800 Black	-	-	-	-
40	M2SS-1E-1300 Red	M2SS-1E-1300 Red	M2SS-1E-800 Black	M2SS-1E-1060N Black/Dk Blue	-	-	-	-
52	M2SS-1E-1300 Red	M2SS-1E-1650N Red/Dk Blue	M2SS-1E-1060N Black/Dk Blue	M2SS-1E-1060N Black/Dk Blue	-	-	-	-
60	M2SS-1E-1650N Red/Dk Blue	M2SS-1E-1650N Red/Dk Blue	M2SS-1E-1060N Black/Dk Blue	M2SS-1E-1060N Black/Dk Blue	M2SS-1E-800 Black	M2SS-1E-800 Black	-	-
70	M2SS-1E-1650N Red/Dk Blue	M2SS-1E-1650N Red/Dk Blue	M2SS-1E-1060N Black/Dk Blue	M2SS-1E-1060N Black/Dk Blue	M2SS-1E-800 Black	M2SS-1E-800 Black	-	-
80	M2SS-1E-2000 Tan	M2SS-1E-2000 Tan	M2SS-1E-1060N Black/Dk Blue	M2SS-1E-1300 Red	M2SS-1E-800 Black	M2SS-1E-800 Black	-	-
90	M2SS-1E-2000 Tan	M2SS-1E-2000 Tan	M2SS-1E-1060N Black/Dk Blue	M2SS-1E-1650N Red/Dk Blue	M2SS-1E-800 Black	M2SS-1E-800 Black	-	-
100	M2SS-1E-2000 Tan	M2SS-1E-2000 Tan	M2SS-1E-1300 Red	M2SS-1E-1650N Red/Dk Blue	M2SS-1E-800 Black	M2SS-1E-800 Black	-	-
110	M2SS-1E-2000 Tan	M2SS-1E-2000 Tan	M2SS-1E-1300 Red	M2SS-1E-1650N Red/Dk Blue	M2SS-1E-800 Black	M2SS-1E-800 Black	-	-
120	M2SS-1E-2000 Tan	M2SS-1E-2000 Tan	M2SS-1E-1300 Red	M2SS-1E-2000 Tan	M2SS-1E-800 Black	M2SS-1E-800 Black	-	-
130	M2SS-1E-1650N Red/Dk Blue	M2SS-1E-1650N Red/Dk Blue	M2SS-1E-1300 Red	M2SS-1E-1650N Red/Dk Blue	M2SS-1E-1060N Black/Dk Blue	M2SS-1E-1300 Red	M2SS-1E-800 Black	M2SS-1E-1060N Black/Dk Blue

Mounting Point Weights
Units with Round Tube, Plate Fin (RTPF) Condensers
Table 32. Point weights (lbs) – RTPF condensers, 60 Hz, high efficiency— base unit

Unit Size (tons)	Isolator location															
	Aluminum Fins								Copper Fins							
	1	2	3	4	5	6	7	8	1	2	3	4	5	6	7	8
High Efficiency Units without Partial Heat Recovery																
20	706	645	408	365	-	-	-	-	822	648	425	487	-	-	-	-
26	792	614	369	420	-	-	-	-	807	716	486	442	-	-	-	-
30	775	805	595	431	-	-	-	-	916	828	641	581	-	-	-	-
35	894	861	645	436	-	-	-	-	1035	884	690	587	-	-	-	-
40	1151	1036	611	811	-	-	-	-	1198	1246	823	858	-	-	-	-
52	1080	1155	714	768	-	-	-	-	1209	1283	843	898	-	-	-	-
60	972	1104	630	762	602	492	-	-	1100	1167	855	904	610	644	-	-
70	1117	1210	781	849	511	557	-	-	1239	1330	910	977	622	668	-	-
80	1435	1662	774	885	396	449	-	-	1795	1834	863	1203	581	594	-	-
90	1507	1763	802	927	406	466	-	-	1872	1930	887	1249	591	610	-	-
100	1640	1587	847	1120	608	866	-	-	1770	1992	1194	1342	886	994	-	-
110	1673	1634	850	1134	602	863	-	-	1803	2038	1200	1356	878	993	-	-
120	1690	1651	853	1138	600	861	-	-	1820	2055	1204	1360	875	990	-	-
130	1284	1272	910	1229	861	852	569	826	1269	1749	1301	1197	989	1246	1008	932
High Efficiency Units with Partial Heat Recovery																
20	707	660	414	382	-	-	-	-	773	713	482	453	-	-	-	-
26	793	629	375	437	-	-	-	-	752	789	550	402	-	-	-	-
30	836	773	545	502	-	-	-	-	921	852	645	597	-	-	-	-
35	955	829	593	507	-	-	-	-	1041	908	694	603	-	-	-	-
40	1062	1111	749	785	-	-	-	-	1191	1239	879	914	-	-	-	-
52	1073	1148	770	825	-	-	-	-	1202	1275	900	954	-	-	-	-
60	931	988	827	884	504	543	-	-	1170	1119	863	825	591	829	-	-
70	1097	1190	812	880	558	604	-	-	1311	1280	917	895	600	858	-	-
80	1528	1756	780	891	384	437	-	-	1888	1926	871	1213	568	580	-	-
90	1602	1858	807	932	394	454	-	-	1966	2023	896	1260	577	596	-	-
100	1732	1680	860	1138	596	848	-	-	1861	2083	1213	1361	869	978	-	-
110	1765	1726	864	1152	589	845	-	-	1934	1895	1209	1774	829	810	-	-
120	1783	1744	867	1156	587	843	-	-	1953	1912	1214	1780	827	807	-	-
130	1129	1587	1144	1072	855	803	589	812	1589	1475	1145	1605	938	1203	990	934



Installation - Mechanical

Table 33. Point weights (lbs) – RTPF condensers, 60 Hz, extra efficiency— base unit

Unit Size (tons)	Isolator location															
	Aluminum Fins								Copper Fins							
	1	2	3	4	5	6	7	8	1	2	3	4	5	6	7	8
Units without Partial Heat Recovery																
20	724	663	426	383	-	-	-	-	872	698	476	537	-	-	-	-
26	810	632	387	439	-	-	-	-	858	766	536	493	-	-	-	-
30	800	830	620	456	-	-	-	-	986	898	711	651	-	-	-	-
35	919	886	669	460	-	-	-	-	1105	954	760	657	-	-	-	-
40	1188	1073	647	848	-	-	-	-	1298	1346	923	958	-	-	-	-
52	1117	1192	750	805	-	-	-	-	1310	1383	944	998	-	-	-	-
60	1005	1137	663	795	635	525	-	-	1193	1261	948	998	704	737	-	-
70	1150	1243	814	882	544	591	-	-	1332	1423	1004	1071	715	761	-	-
110	1673	1634	850	1134	602	863	-	-	1803	2038	1200	1356	878	993	-	-
120	1690	1651	853	1138	600	861	-	-	1820	2055	1204	1360	875	990	-	-
Units with Partial Heat Recovery																
20	726	679	433	400	-	-	-	-	823	763	532	504	-	-	-	-
26	811	648	393	456	-	-	-	-	802	839	600	453	-	-	-	-
30	861	798	569	527	-	-	-	-	991	922	715	667	-	-	-	-
35	980	854	618	532	-	-	-	-	1111	978	764	673	-	-	-	-
40	1098	1147	785	821	-	-	-	-	1291	1339	979	1014	-	-	-	-
52	1110	1184	806	861	-	-	-	-	1302	1376	1000	1054	-	-	-	-
60	965	1022	860	917	537	576	-	-	1263	1212	956	919	684	923	-	-
70	1131	1223	845	913	591	637	-	-	1404	1373	1011	988	694	951	-	-
110	1765	1726	864	1152	589	845	-	-	1934	1895	1209	1774	829	810	-	-
120	1783	1744	867	1156	587	843	-	-	1953	1912	1214	1780	827	807	-	-

Table 34. Point weights (lbs) – RTPF condensers, 60 Hz, high efficiency – with pump package (no buffer tank)

Size (tons)	Isolator location															
	Aluminum Fins								Copper Fins							
	1	2	3	4	5	6	7	8	1	2	3	4	5	6	7	8
Units without Partial Heat Recovery																
20	874	612	603	618	-	-	-	-	802	802	809	552	-	-	-	-
26	910	630	614	624	-	-	-	-	834	824	823	554	-	-	-	-
30	832	836	904	619	-	-	-	-	989	842	933	787	-	-	-	-
35	946	896	958	619	-	-	-	-	1182	824	908	865	-	-	-	-
40	1214	1109	1009	932	-	-	-	-	1336	1244	1146	1054	-	-	-	-
52	1225	1146	1030	972	-	-	-	-	1349	1279	1165	1095	-	-	-	-
60	1204	943	802	862	734	794	-	-	1250	1192	923	880	928	885	-	-
70	1261	1226	866	840	818	792	-	-	1290	1258	1196	1163	819	795	-	-
80	1296	1663	922	1070	901	763	-	-	1637	1812	1190	1306	927	1012	-	-
90	1556	1616	816	1152	857	886	-	-	1712	1910	1217	1349	934	1031	-	-
100	1278	1684	1330	1175	1013	1226	-	-	1561	1736	1653	1827	1162	1278	-	-
110	1305	1733	1339	1189	1006	1221	-	-	1593	1778	1661	1846	1151	1275	-	-
120	1276	1623	1280	1629	1284	1091	-	-	1742	1721	1721	1699	1133	1678	-	-
130	835	1195	1150	1206	1167	1223	1177	1233	1341	1335	1253	1247	1116	1664	1564	1555
Units with Partial Heat Recovery																
20	877	626	609	636	-	-	-	-	802	819	816	568	-	-	-	-
26	851	706	680	581	-	-	-	-	835	841	830	570	-	-	-	-
30	837	859	909	635	-	-	-	-	996	864	936	804	-	-	-	-
35	1025	846	889	709	-	-	-	-	1189	846	910	884	-	-	-	-
40	1118	1190	1154	899	-	-	-	-	1328	1236	1202	1110	-	-	-	-
52	1127	1229	1177	937	-	-	-	-	1341	1271	1222	1152	-	-	-	-
60	1186	928	824	883	786	845	-	-	1234	1175	945	903	979	936	-	-
70	1245	1209	889	863	869	843	-	-	1272	1239	1224	1191	868	844	-	-
80	1569	1609	804	1123	832	851	-	-	1727	1902	1203	1320	910	996	-	-
90	1648	1707	826	1166	842	870	-	-	1803	2001	1230	1362	918	1015	-	-
100	1584	1635	1178	1212	951	1331	-	-	1648	1822	1680	1854	1141	1257	-	-
110	1616	1680	1183	1226	943	1329	-	-	1680	1865	1688	1873	1131	1254	-	-
120	1586	1561	1136	1679	1212	1196	-	-	1827	1809	1748	1730	1114	1653	-	-
130	1066	1198	1089	1221	1124	1256	1143	1275	1381	1114	1358	1638	1323	1585	1305	1557



Installation - Mechanical

Table 35. Point weights (lbs) – RTPF condensers, 60 Hz, extra efficiency – with pump package (no buffer tank)

Size (tons)	Isolator location															
	Aluminum Fins								Copper Fins							
	1	2	3	4	5	6	7	8	1	2	3	4	5	6	7	8
Units without Partial Heat Recovery																
20	893	630	621	637	-	-	-	-	852	853	859	602	-	-	-	-
26	928	649	632	642	-	-	-	-	884	875	873	605	-	-	-	-
30	856	860	929	644	-	-	-	-	1059	912	1003	857	-	-	-	-
35	971	921	983	644	-	-	-	-	1252	894	978	935	-	-	-	-
40	1250	1145	1046	969	-	-	-	-	1436	1344	1246	1155	-	-	-	-
52	1262	1182	1066	1008	-	-	-	-	1449	1379	1265	1196	-	-	-	-
60	1237	976	835	895	767	827	-	-	1343	1285	1016	974	1021	979	-	-
70	1294	1259	899	874	851	825	-	-	1384	1351	1289	1257	913	889	-	-
110	1305	1733	1339	1189	1006	1221	-	-	1593	1778	1661	1846	1151	1275	-	-
120	1276	1623	1280	1629	1284	1091	-	-	1742	1721	1721	1699	1133	1678	-	-
Units with Partial Heat Recovery																
20	895	644	627	655	-	-	-	-	852	869	867	618	-	-	-	-
26	870	724	699	599	-	-	-	-	885	891	881	621	-	-	-	-
30	862	884	934	660	-	-	-	-	1066	934	1006	874	-	-	-	-
35	1050	871	913	734	-	-	-	-	1259	916	980	954	-	-	-	-
40	1154	1227	1190	936	-	-	-	-	1429	1337	1302	1210	-	-	-	-
52	1164	1265	1213	974	-	-	-	-	1442	1372	1322	1252	-	-	-	-
60	1219	962	857	916	819	878	-	-	1327	1269	1039	996	1072	1030	-	-
70	1278	1242	922	896	902	876	-	-	1365	1332	1317	1284	961	937	-	-
110	1616	1680	1183	1226	943	1329	-	-	1680	1865	1688	1873	1131	1254	-	-
120	1586	1561	1136	1679	1212	1196	-	-	1827	1809	1748	1730	1114	1653	-	-

Table 36. Point weights (lbs) – RTPF condensers, 60 Hz, high efficiency – with pump package and buffer tank

Size (tons)	Isolator location															
	Aluminum Fins								Copper Fins							
	1	2	3	4	5	6	7	8	1	2	3	4	5	6	7	8
Units without Partial Heat Recovery																
20	616	413	1728	1650	-	-	-	-	610	538	1867	1650	-	-	-	-
26	650	434	1741	1653	-	-	-	-	640	562	1883	1650	-	-	-	-
30	663	585	1939	1703	-	-	-	-	848	564	1940	1898	-	-	-	-
35	868	555	1902	1793	-	-	-	-	865	722	2092	1800	-	-	-	-
40	838	790	2265	2135	-	-	-	-	966	918	2395	2264	-	-	-	-
52	856	820	2279	2181	-	-	-	-	985	948	2409	2310	-	-	-	-
60	679	656	1237	1191	1704	1636	-	-	867	835	1224	1181	1889	1825	-	-
70	875	857	1184	1159	1765	1726	-	-	1001	981	1304	1278	1881	1841	-	-
80	1868	2086	1234	1379	898	1005	-	-	1892	2452	1703	1649	1040	1005	-	-
90	1873	2145	1281	1657	957	828	-	-	2169	2399	1565	1738	1012	1127	-	-
100	1681	2251	1788	1796	1262	1267	-	-	2291	2524	1638	1812	1559	1733	-	-
110	1710	2298	1797	1810	1254	1263	-	-	2324	2568	1645	1828	1549	1732	-	-
120	1861	2235	1856	1671	1234	1666	-	-	2313	2561	1709	1895	1684	1870	-	-
130	1209	1222	1148	1741	1579	1599	1504	1523	1110	1688	1706	1728	1768	1790	1801	1824
Units with Partial Heat Recovery																
20	623	423	1729	1672	-	-	-	-	616	549	1870	1670	-	-	-	-
26	585	516	1813	1604	-	-	-	-	646	574	1886	1671	-	-	-	-
30	674	603	1938	1724	-	-	-	-	860	581	1938	1920	-	-	-	-
35	880	572	1900	1816	-	-	-	-	874	742	2092	1821	-	-	-	-
40	830	783	2321	2191	-	-	-	-	959	911	2451	2320	-	-	-	-
52	849	813	2336	2238	-	-	-	-	977	941	2466	2367	-	-	-	-
60	668	645	1248	1202	1762	1693	-	-	855	824	1238	1194	1945	1881	-	-
70	864	845	1198	1172	1821	1783	-	-	989	969	1317	1291	1938	1898	-	-
80	1823	2357	1284	1248	980	953	-	-	2217	2292	1679	1736	827	1165	-	-
90	1959	2242	1296	1666	944	809	-	-	2292	2389	1709	1781	832	1183	-	-
100	1762	2347	1816	1814	1246	1245	-	-	2380	2612	1661	1835	1540	1714	-	-
110	1791	2394	1825	1829	1238	1241	-	-	2412	2656	1668	1851	1530	1713	-	-
120	1941	2333	1885	1694	1220	1639	-	-	2403	2651	1733	1919	1665	1851	-	-
130	1157	1611	1132	1573	1638	1513	1607	1482	1476	1637	1559	1720	1688	1849	1756	1918



Installation - Mechanical

Table 37. Point weights (lbs) – RTPF condensers, 60 Hz, extra efficiency – with pump package and buffer tank

Size (tons)	Isolator location															
	Aluminum Fins								Copper Fins							
	1	2	3	4	5	6	7	8	1	2	3	4	5	6	7	8
Units without Partial Heat Recovery																
20	635	432	1746	1668	-	-	-	-	660	588	1917	1700	-	-	-	-
26	668	453	1759	1671	-	-	-	-	690	612	1934	1700	-	-	-	-
30	688	610	1964	1728	-	-	-	-	918	634	2010	1968	-	-	-	-
35	893	580	1927	1818	-	-	-	-	935	792	2162	1870	-	-	-	-
40	874	827	2302	2172	-	-	-	-	1067	1018	2496	2364	-	-	-	-
52	892	857	2315	2218	-	-	-	-	1085	1049	2510	2411	-	-	-	-
60	712	689	1270	1224	1737	1669	-	-	960	929	1318	1275	1982	1918	-	-
70	909	890	1217	1192	1798	1760	-	-	1094	1075	1398	1371	1974	1935	-	-
110	1710	2298	1797	1810	1254	1263	-	-	2324	2568	1645	1828	1549	1732	-	-
120	1861	2235	1856	1671	1234	1666	-	-	2313	2561	1709	1895	1684	1870	-	-
Units with Partial Heat Recovery																
20	642	441	1747	1690	-	-	-	-	666	599	1920	1720	-	-	-	-
26	604	534	1831	1622	-	-	-	-	696	624	1936	1721	-	-	-	-
30	699	628	1963	1749	-	-	-	-	930	650	2008	1990	-	-	-	-
35	905	597	1925	1841	-	-	-	-	944	812	2162	1891	-	-	-	-
40	867	819	2358	2227	-	-	-	-	1059	1011	2552	2420	-	-	-	-
52	885	849	2372	2274	-	-	-	-	1077	1041	2566	2467	-	-	-	-
60	701	678	1281	1235	1795	1726	-	-	949	917	1331	1288	2039	1974	-	-
70	897	878	1231	1205	1855	1816	-	-	1082	1063	1411	1384	2031	1991	-	-
110	1791	2394	1825	1829	1238	1241	-	-	2412	2656	1668	1851	1530	1713	-	-
120	1941	2333	1885	1694	1220	1639	-	-	2403	2651	1733	1919	1665	1851	-	-

Table 38. Point weights (lbs) – RTPF condensers, 50 Hz, high efficiency – base unit

Size (tons)	Isolator location											
	Aluminum Fins						Copper Fins					
	1	2	3	4	5	6	1	2	3	4	5	6
Units without Partial Heat Recovery												
20	767	605	348	405	-	-	833	658	415	478	-	-
26	792	614	369	420	-	-	807	716	486	442	-	-
30	775	805	595	431	-	-	916	828	641	581	-	-
35	894	861	645	436	-	-	1035	884	690	587	-	-
40	1151	1036	611	811	-	-	1198	1246	823	858	-	-
52	1080	1155	714	768	-	-	1209	1283	843	898	-	-
60	972	1104	630	762	602	492	1100	1167	855	904	610	644
70	1117	1210	781	849	511	557	1239	1330	910	977	622	668
80	1435	1662	774	885	396	449	1795	1834	863	1203	581	594
90	1507	1763	802	926	406	465	1872	1930	887	1249	591	610
100	1654	1605	840	1113	593	847	1786	2008	1188	1336	869	977
110	1670	1632	849	1132	600	861	1801	2036	1198	1354	876	991
120	1689	1650	853	1137	599	860	1820	2054	1203	1359	875	990
Units with Partial Heat Recovery												
20	768	621	354	422	-	-	784	724	472	444	-	-
26	793	629	375	437	-	-	752	789	549	402	-	-
30	836	773	545	502	-	-	921	852	645	597	-	-
35	955	829	593	507	-	-	1041	907	694	603	-	-
40	1062	1111	749	785	-	-	1191	1239	879	914	-	-
52	1073	1148	769	824	-	-	1202	1276	899	953	-	-
60	931	988	827	884	504	543	1170	1119	863	825	591	829
70	1098	1190	812	880	558	604	1311	1280	917	894	600	857
80	1528	1756	780	891	384	437	1888	1926	871	1213	568	580
90	1601	1856	807	932	394	454	1964	2022	895	1259	577	596
100	1745	1697	853	1131	581	829	1876	2098	1206	1354	852	961
110	1762	1724	862	1150	588	844	1932	1893	1208	1772	828	809
120	1781	1743	866	1155	587	842	1951	1911	1213	1779	826	806



Installation - Mechanical

Table 39. Point weights (lbs) – RTPF condensers, 50 Hz, extra efficiency – base unit

Size (tons)	Isolator location											
	Aluminum Fins						Copper Fins					
	1	2	3	4	5	6	1	2	3	4	5	6
Units without Partial Heat Recovery												
20	785	624	366	424	-	-	883	708	465	528	-	-
26	810	632	387	439	-	-	858	766	536	493	-	-
30	800	830	620	456	-	-	986	898	711	651	-	-
35	919	886	669	460	-	-	1105	954	760	657	-	-
40	1188	1073	647	848	-	-	1298	1346	923	958	-	-
52	1117	1192	750	805	-	-	1310	1383	944	998	-	-
60	1005	1137	663	795	635	525	1193	1261	948	998	704	737
70	1150	1243	814	882	544	591	1332	1423	1004	1071	715	761
110	1670	1632	849	1132	600	861	1801	2036	1198	1354	876	991
120	1689	1650	853	1137	599	860	1820	2054	1203	1359	875	990
Units with Partial Heat Recovery												
20	787	639	373	440	-	-	834	774	522	494	-	-
26	811	647	393	455	-	-	802	839	600	452	-	-
30	861	798	569	527	-	-	991	922	715	667	-	-
35	980	854	618	532	-	-	1111	977	764	673	-	-
40	1098	1147	785	821	-	-	1291	1339	979	1014	-	-
52	1110	1184	806	861	-	-	1302	1376	1000	1054	-	-
60	965	1022	860	917	537	576	1263	1212	956	919	684	923
70	1131	1223	845	913	591	637	1405	1374	1010	988	693	951
110	1762	1724	862	1150	588	844	1932	1893	1208	1772	828	809
120	1781	1743	866	1155	587	842	1951	1911	1213	1779	826	806

Table 40. Point weights (lbs) – RTPF condensers, 50 Hz, high efficiency – with pump package (no buffer tank)

Size (tons)	Isolator location											
	Aluminum Fins						Copper Fins					
	1	2	3	4	5	6	1	2	3	4	5	6
Units without Partial Heat Recovery												
20	812	680	582	496	-	-	873	737	655	562	-	-
26	894	631	546	568	-	-	896	747	677	576	-	-
30	828	834	823	565	-	-	979	847	858	726	-	-
35	943	895	887	572	-	-	1173	829	843	812	-	-
40	1193	1119	942	888	-	-	1232	1336	1162	928	-	-
52	1204	1156	963	928	-	-	1329	1287	1096	1053	-	-
60	1206	933	821	870	768	817	1252	1181	942	889	962	909
70	1264	1215	885	850	851	815	1291	1246	1220	1174	851	818
80	1298	1666	914	1059	885	748	1641	1815	1179	1296	912	997
90	1558	1619	807	1141	841	871	1716	1913	1206	1338	919	1016
100	1292	1707	1316	1162	983	1185	1581	1755	1637	1811	1128	1244
110	1306	1735	1328	1179	989	1200	1596	1780	1649	1833	1134	1257
120	1271	1847	1244	1204	1218	1178	1754	1743	1673	1661	1062	1581
Units with Partial Heat Recovery												
20	872	636	530	571	-	-	874	753	661	579	-	-
26	896	645	551	585	-	-	897	763	684	592	-	-
30	833	858	828	581	-	-	986	869	861	744	-	-
35	948	919	892	588	-	-	1180	850	846	830	-	-
40	1185	1111	998	944	-	-	1309	1244	1133	1068	-	-
52	1197	1148	1019	983	-	-	1322	1279	1152	1109	-	-
60	1188	919	844	891	821	868	1123	1179	1184	910	906	947
70	1248	1198	908	872	902	866	1273	1227	1247	1202	899	866
80	1572	1612	796	1112	816	836	1731	1906	1192	1309	896	981
90	1650	1709	818	1154	826	855	1806	2003	1220	1351	903	999
100	1600	1655	1162	1199	921	1292	1667	1841	1664	1838	1107	1223
110	1617	1683	1172	1216	927	1308	1683	1867	1676	1860	1113	1236
120	1600	1581	1098	1627	1128	1115	1681	1867	1724	1910	1177	1301



Installation - Mechanical

Table 41. Point weights (lbs) – RTPF condensers, 50 Hz, extra efficiency – with pump package (no buffer tank)

Size (tons)	Isolator location											
	Aluminum Fins						Copper Fins					
	1	2	3	4	5	6	1	2	3	4	5	6
Units without Partial Heat Recovery												
20	830	698	600	514	-	-	923	788	705	613	-	-
26	912	649	564	586	-	-	946	797	727	626	-	-
30	853	859	848	590	-	-	1049	917	928	796	-	-
35	968	920	912	597	-	-	1243	899	913	882	-	-
40	1229	1155	979	925	-	-	1332	1436	1262	1028	-	-
52	1240	1192	999	964	-	-	1430	1387	1197	1154	-	-
60	1239	966	854	903	801	850	1346	1274	1035	983	1055	1002
70	1297	1248	919	883	884	848	1384	1339	1313	1268	944	911
110	1306	1735	1328	1179	989	1200	1596	1780	1649	1833	1134	1257
120	1271	1847	1244	1204	1218	1178	1754	1743	1673	1661	1062	1581
Units with Partial Heat Recovery												
20	891	654	548	589	-	-	924	803	712	629	-	-
26	914	663	569	604	-	-	947	813	734	642	-	-
30	858	882	853	606	-	-	1056	939	931	814	-	-
35	973	943	917	613	-	-	1250	920	916	900	-	-
40	1222	1148	1035	980	-	-	1409	1344	1234	1168	-	-
52	1233	1184	1055	1020	-	-	1423	1379	1253	1209	-	-
60	1221	952	877	924	854	901	1216	1272	1278	1003	1000	1041
70	1281	1232	941	905	935	899	1366	1321	1341	1295	992	959
110	1617	1683	1172	1216	927	1308	1683	1867	1676	1860	1113	1236
120	1600	1581	1098	1627	1128	1115	1681	1867	1724	1910	1177	1301

Table 42. Point weights (lbs) – RTPF condensers, 50 Hz, high efficiency – with pump package and buffer tank options

Size (tons)	Isolator location											
	Aluminum Fins						Copper Fins					
	1	2	3	4	5	6	1	2	3	4	5	6
Units without Partial Heat Recovery												
20	617	419	1644	1589	-	-	610	544	1784	1588	-	-
26	638	431	1668	1601	-	-	629	558	1810	1598	-	-
30	657	586	1861	1646	-	-	841	566	1863	1840	-	-
35	862	557	1835	1743	-	-	859	724	2024	1750	-	-
40	735	881	2280	2010	-	-	953	920	2320	2228	-	-
52	843	822	2204	2146	-	-	972	950	2334	2275	-	-
60	679	651	1252	1195	1744	1659	869	829	1239	1186	1928	1848
70	877	851	1200	1163	1804	1749	1002	975	1319	1282	1920	1864
80	1872	2089	1223	1368	884	990	2131	2206	1654	1710	829	1167
90	1875	2150	1270	1642	942	814	2206	2301	1684	1755	834	1185
100	1700	2272	1773	1778	1230	1233	2309	2541	1626	1800	1523	1697
110	1713	2300	1785	1797	1237	1245	2325	2568	1636	1818	1530	1712
120	1872	2259	1808	1631	1164	1568	2329	2575	1672	1856	1599	1783
Units with Partial Heat Recovery												
20	624	429	1645	1611	-	-	615	556	1787	1609	-	-
26	574	511	1740	1552	-	-	634	569	1813	1619	-	-
30	668	604	1860	1668	-	-	853	582	1861	1863	-	-
35	874	574	1832	1766	-	-	868	743	2024	1770	-	-
40	817	784	2246	2155	-	-	946	912	2376	2284	-	-
52	836	814	2260	2201	-	-	964	942	2390	2330	-	-
60	669	640	1263	1206	1801	1716	857	818	1253	1199	1984	1904
70	865	839	1213	1176	1860	1805	991	963	1332	1295	1976	1920
80	1827	2361	1274	1237	965	938	2220	2297	1666	1724	815	1149
90	1961	2246	1285	1652	930	795	2295	2392	1696	1769	820	1167
100	1780	2367	1801	1796	1214	1211	2467	2452	1850	1839	1234	1839
110	1794	2396	1813	1816	1221	1223	2484	2479	1861	1857	1239	1855
120	1950	2356	1837	1653	1150	1542	2418	2663	1695	1879	1580	1764



Installation - Mechanical

Table 43. Point weights (lbs) – RTPF condensers, 50 Hz, extra efficiency – with pump package and buffer tank options

Size (tons)	Isolator location											
	Aluminum Fins						Copper Fins					
	1	2	3	4	5	6	1	2	3	4	5	6
Units without Partial Heat Recovery												
20	635	437	1662	1607	-	-	660	594	1834	1638	-	-
26	656	449	1686	1619	-	-	679	608	1861	1648	-	-
30	682	611	1886	1671	-	-	911	636	1933	1910	-	-
35	887	582	1860	1768	-	-	928	794	2094	1820	-	-
40	771	918	2316	2046	-	-	1054	1020	2421	2328	-	-
52	879	858	2240	2182	-	-	1072	1050	2435	2375	-	-
60	712	684	1285	1228	1777	1692	962	923	1333	1279	2021	1941
70	910	884	1233	1197	1837	1782	1096	1069	1413	1376	2013	1958
110	1713	2300	1785	1797	1237	1245	2325	2568	1636	1818	1530	1712
120	1872	2259	1808	1631	1164	1568	2329	2575	1672	1856	1599	1783
Units with Partial Heat Recovery												
20	642	447	1663	1630	-	-	665	606	1837	1659	-	-
26	592	530	1758	1570	-	-	684	620	1863	1669	-	-
30	693	629	1885	1692	-	-	923	652	1931	1933	-	-
35	899	599	1857	1791	-	-	938	813	2094	1840	-	-
40	854	820	2283	2191	-	-	1046	1012	2477	2384	-	-
52	872	851	2296	2238	-	-	1065	1043	2491	2430	-	-
60	702	673	1296	1239	1834	1749	950	911	1346	1292	2077	1997
70	898	872	1246	1210	1893	1838	1084	1057	1426	1389	2069	2014
110	1794	2396	1813	1816	1221	1223	2484	2479	1861	1857	1239	1855
120	1950	2356	1837	1653	1150	1542	2418	2663	1695	1879	1580	1764

Units with Microchannel Condenser
Table 44. Point weights (lbs) – microchannel condenser units

Size (tons)	Isolator location															
	60 Hz Units								50 Hz Units							
	1	2	3	4	5	6	7	8	1	2	3	4	5	6	7	8
Base Unit																
20	670	608	364	334	-	-	-	-	681	618	354	324	-	-	-	-
26	705	627	375	338	-	-	-	-	705	627	375	338	-	-	-	-
30	782	700	480	441	-	-	-	-	782	700	480	441	-	-	-	-
35	793	864	637	337	-	-	-	-	793	864	637	337	-	-	-	-
40	920	1133	693	566	-	-	-	-	920	1133	693	566	-	-	-	-
52	930	1171	715	605	-	-	-	-	930	1171	715	605	-	-	-	-
60	853	916	793	856	354	383	-	-	853	916	793	856	354	383	-	-
70	1145	1083	735	692	324	637	-	-	1145	1083	735	692	324	637	-	-
80	1160	1613	755	713	339	319	-	-	1160	1613	755	713	339	319	-	-
90	1225	1719	787	751	350	332	-	-	1224	1719	787	750	350	332	-	-
100	1231	1756	769	746	679	656	-	-	1245	1773	765	740	662	637	-	-
110	1260	1806	776	756	673	653	-	-	1258	1803	775	755	671	651	-	-
120	1277	1826	782	760	672	650	-	-	1276	1825	781	759	672	650	-	-
130	1158	1258	836	910	556	890	549	599	-	-	-	-	-	-	-	-
Unit with Pump Package (No Buffer Tank)																
20	765	647	632	514	-	-	-	-	-	-	-	-	-	-	-	-
26	798	669	646	517	-	-	-	-	-	-	-	-	-	-	-	-
30	851	717	776	642	-	-	-	-	-	-	-	-	-	-	-	-
35	965	778	829	642	-	-	-	-	-	-	-	-	-	-	-	-
40	1232	957	842	937	-	-	-	-	-	-	-	-	-	-	-	-
52	1159	1078	948	892	-	-	-	-	-	-	-	-	-	-	-	-
60	1010	964	835	789	690	643	-	-	-	-	-	-	-	-	-	-
70	1199	1164	790	765	749	724	-	-	-	-	-	-	-	-	-	-
80	1263	1420	788	898	716	826	-	-	-	-	-	-	-	-	-	-
90	1339	1516	814	939	722	846	-	-	-	-	-	-	-	-	-	-
100	1253	1297	1178	1223	774	1150	-	-	-	-	-	-	-	-	-	-
110	1284	1339	1186	1241	763	1146	-	-	-	-	-	-	-	-	-	-
120	1280	1322	1268	1310	879	1298	-	-	-	-	-	-	-	-	-	-
130	946	845	949	1157	954	1164	957	1168	-	-	-	-	-	-	-	-
Units with Pump Package and Buffer Tank																
20	640	317	1625	1678	-	-	-	-	-	-	-	-	-	-	-	-
26	676	334	1634	1685	-	-	-	-	-	-	-	-	-	-	-	-
30	624	526	1870	1667	-	-	-	-	-	-	-	-	-	-	-	-
35	728	596	1933	1657	-	-	-	-	-	-	-	-	-	-	-	-
40	775	718	2179	2059	-	-	-	-	-	-	-	-	-	-	-	-
52	792	750	2194	2104	-	-	-	-	-	-	-	-	-	-	-	-
60	666	636	1061	1018	1688	1626	-	-	-	-	-	-	-	-	-	-
70	798	780	1142	1117	1678	1641	-	-	-	-	-	-	-	-	-	-
80	1700	1918	1149	1298	799	903	-	-	-	-	-	-	-	-	-	-
90	1775	2015	1177	1340	806	921	-	-	-	-	-	-	-	-	-	-
100	1863	1864	1241	1821	1213	1213	-	-	-	-	-	-	-	-	-	-
110	1895	1906	1247	1839	1203	1210	-	-	-	-	-	-	-	-	-	-
120	1679	1910	1694	1925	1165	1322	-	-	-	-	-	-	-	-	-	-
130	1253	1140	1239	1126	1218	1657	1207	1640	-	-	-	-	-	-	-	-

Units with Wind Load Option

- Individual point loads for units with wind load option do not exceed 2520 lb.
- See ["Mounting Locations," p. 26](#) for mounting point locations dimensions.
 - Mounting locations 1 through 8 are the same as units without wind load rating. See ["Unit without Wind Load Rating," p. 26](#) for these dimensions.
 - Mounting locations W1 through W4 are additional locations required for wind load rating. See ["Units with Wind Load Rating," p. 29](#).

Table 45. Elastomeric pad quantities

Unit Size (ton)	Quantity Required
40, 52	8
60, 70	8
80, 90	10
100, 110, 120	8
130	10

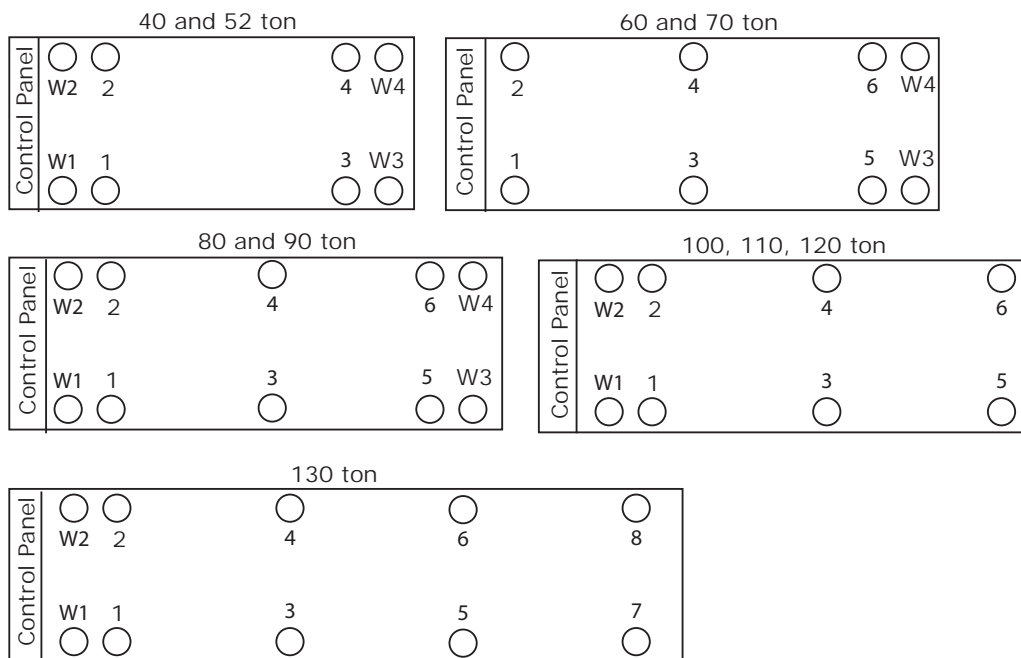
Figure 29. Mounting point identification, units with wind load option

Evaporator Piping

Evaporator water connections are grooved. Thoroughly flush all water piping to the CGAM unit before making the final piping connections to the unit. Components and layout will vary slightly, depending on the location of connections and the water source.

NOTICE:

Equipment Damage!
 If using any commercial flushing/cleaning solution, construct a temporary bypass around the unit to prevent damage to internal components of the evaporator/condenser. Trane assumes no responsibility for equipment damage caused by flushing/cleaning solutions or water-born debris.

NOTICE:

Proper Water Treatment!
 The use of untreated or improperly treated water in a could result in scaling, erosion, corrosion, algae or slime. It is recommended that the services of a qualified water treatment specialist be engaged to determine what water treatment, if any, is required. Trane assumes no responsibility for equipment failures which result from untreated or improperly treated water, or saline or brackish water.

Drainage

Locate the unit near a large capacity drain for water vessel drain-down during shutdown or repair. Drain connections are provided in the chilled water outlet line of evaporator. All local and national codes apply.

A vent is provided on the chilled water inlet line to the evaporator. Additional vents at high points in the piping must be provided to bleed air from the chilled water system. Install necessary pressure gauges to monitor the entering and leaving chilled water pressures.

Provide shutoff valves in lines to the gauges to isolate them from the system when they are not in use. Use rubber vibration eliminators to prevent vibration transmission through the water lines.

If desired, install thermometers in the lines to monitor entering and leaving water temperatures. Install a balancing valve in the leaving water line to control water flow balance. Install shutoff valves on both the entering and leaving water lines so that the evaporator can be isolated for service.

Evaporator Piping Components

Piping components include all devices and controls used to provide proper water system operation and unit operating safety. See [Figure 30, p. 65](#). These components are listed below.

Figure 30. Water piping components

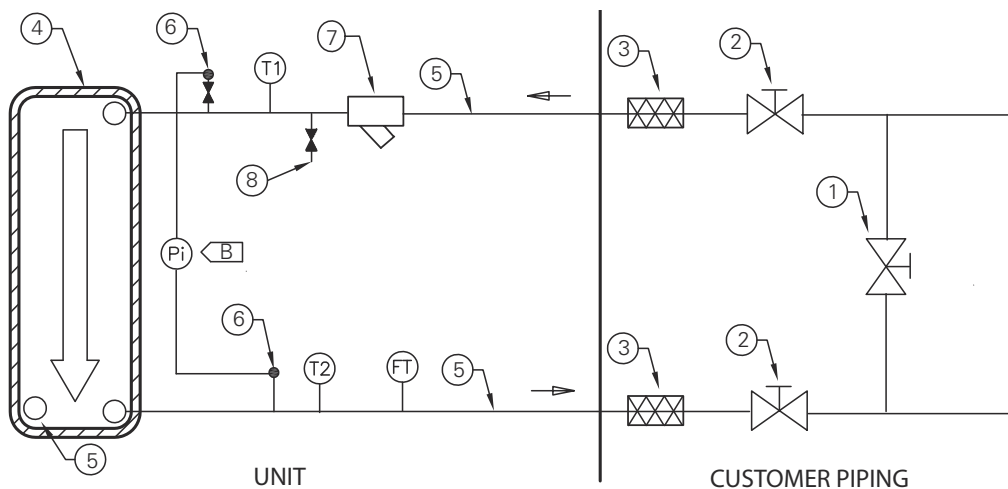

Table 46. Water piping components

Item	Description	Item	Description
1	Bypass Valve	Pi	Gauge
2	Isolation Valves	FT	Water Flow Switch
3	Vibration Eliminators	T1	Evap Water Inlet Temp Sensor
4	Evaporator Heat Exchanger	T2	Evap Water Outlet Temp Sensor
5	Water Heaters	B	Brazed plate differential pressure gauge and piping not supplied. Must account for water head height difference when calculating brazed plate pressure differential.
6	Valve for Pressure Point		
7	Strainer		
8	Water Heater (slant 20-35T units only)		

Entering Chilled Water Piping

- Air vents (to bleed air from system)
- Water pressure gauges with shutoff valves
- Vibration eliminators
- Shutoff (isolation) valves
- Thermometers (if desired)
- Relief valve

Leaving Chilled Water Piping

- Air vents (to bleed air from system)
- Water pressure gauges with shutoff valves
- Vibration eliminators
- Shutoff (isolation) valves
- Thermometers (if desired)
- Balancing valve

NOTICE:

Water Damage!

Failure to follow instructions could result in water spray which could cause equipment and/or property damage. Standard pressure is 72.5 Psig for all factory installed components on the suction side of water pump. Standard pressure of components on the discharge side of water pump is 145 Psig. You **MUST** drain the system **FIRST** before releasing the pressure.

Water Strainer

The water strainer is factory-installed with taps for the pressure gauges on the inlet and outlet. Install pressure gauges in order to measure differential pressure across the filter. This will help to determine when it is necessary to clean the water strainer.

Flow Switch

NOTICE:

Equipment Damage!

Flow switch is on a 24V circuit. Do **NOT** apply 120V to the flow switch. Incorrect voltage application could cause damage to the flow switch.

The flow switch is factory-installed and programmed based on the operating conditions submitted with the order. The leaving evaporator temperature, fluid type and fluid concentration affect the selected flow switch. If the operating conditions on the job site change, the flow switch may need to be replaced.

The sensor head includes 3 LEDs, two yellow and one green. Wait 15 seconds after power is applied to the sensor before evaluating LEDs for flow status. When wired correctly and flow is established, only the green LED should be lit. Following are the LED indicators:

- Green ON, both yellow OFF — Flow

- Green and outside yellow ON — No Flow
- Center yellow ON continuously — Miswire

Factory installed jumper wire W9 must be removed if using auxiliary contacts and/or additional proof of flow. See schematics in CGAM-SVE01*-EN for more details.

Note: Use caution when connecting the auxiliary contacts. Terminals 1X5-3 and 1X5-9 are to be used for field connections of auxiliary contacts. Inadvertent use of 1X5-4 and 1X5-9 will result in a FALSE FLOW indication.

NOTICE:

Equipment Damage!

Failure to follow instructions when wiring auxiliary contacts could cause equipment damage.

If using auxiliary flow sensing, both yellow LEDs come on initially when flow is stopped. The center yellow LED will turn off after approximately 7 seconds. The LED indicators are otherwise the same as indicated above.

Indexing Flow Switch

To properly index the flow switch, the following requirements must be met:

- The dot/dimple must be at a position no greater than 90° off Index.
- The torque must be between 22 ft-lb minimum and 74 ft-lb maximum.
- A minimum distance of 5x pipe diameter must be maintained between flow switch and any bends, valves, changes in cross sections, etc.

Figure 31. Proper flow switch indexing

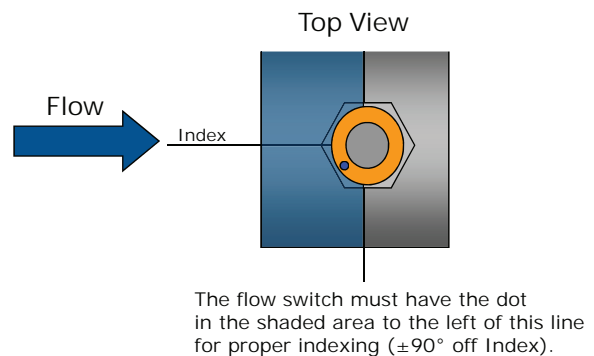

Evaporator Label

The BPHE evaporator label, including barcode, is located under the insulation, in the locations shown in [Figure 32, p. 67](#). Insulation backing over this area has not been removed, so that it can be rolled back to access BPHE label.

Figure 32. BPHE label locations

20T BPHE - P80

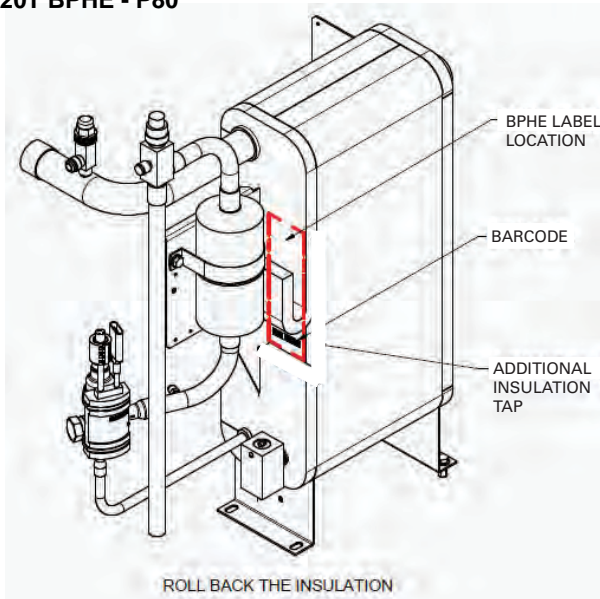

40T BPHE - DP200

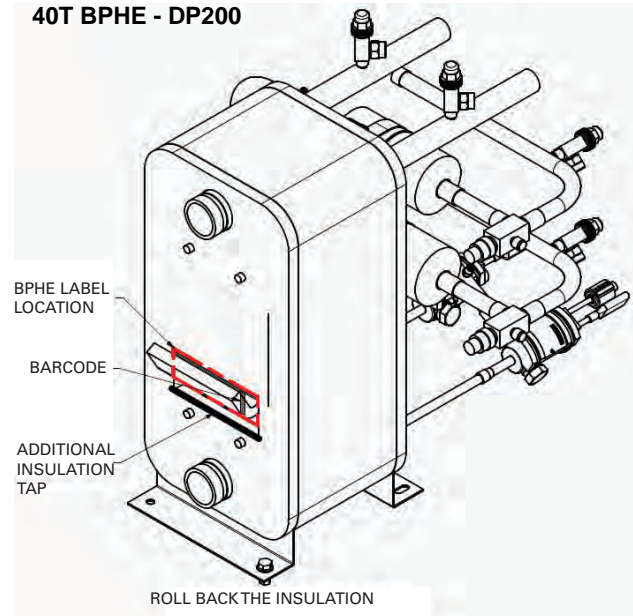

26/30/36T BPHE - P120

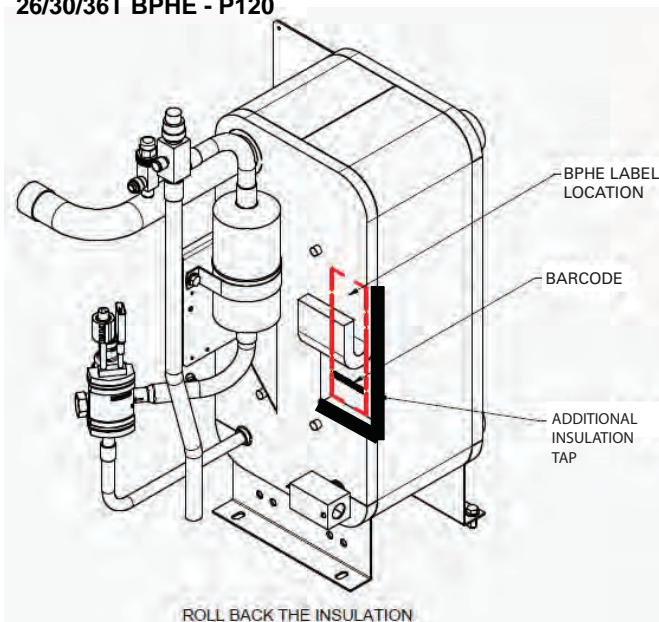

52-130T BPHE - DP400

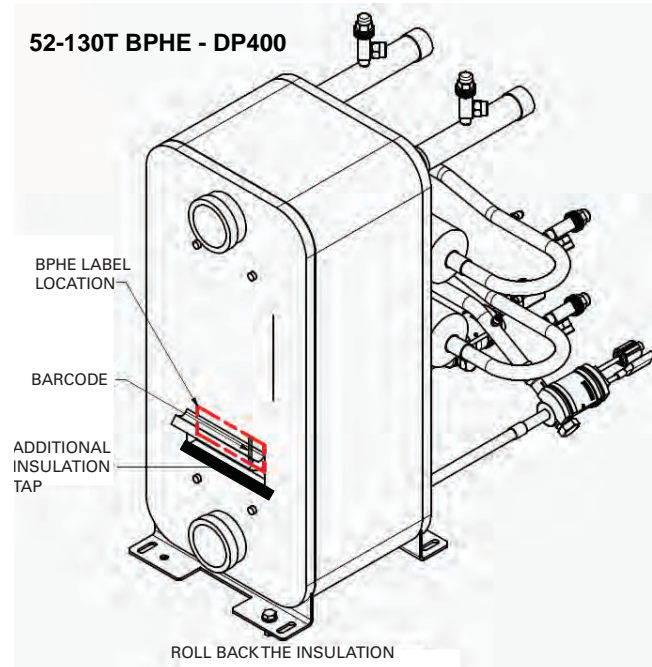

Pressure Drop Curves

Notes: See tables in "General Information," p. 10 for the following:

- Limit values for overlapping curves.
- Higher minimum flow rates required for units with evaporator leaving water temperature between 40 and 41.9°F

Figure 33. Total unit pressure drop curves (60 Hz)

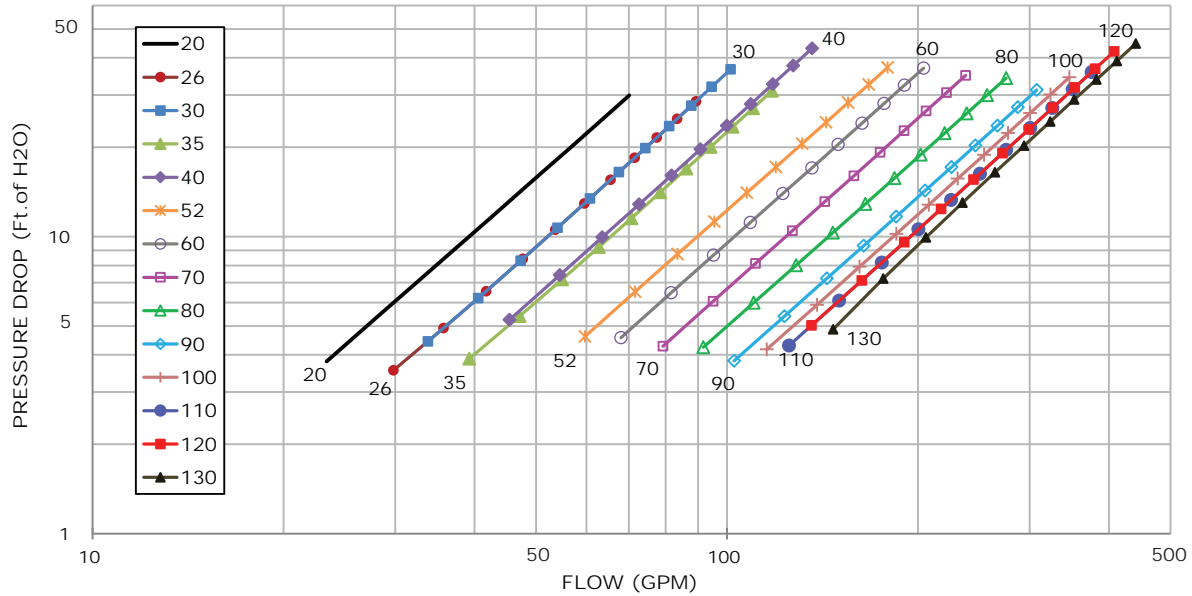
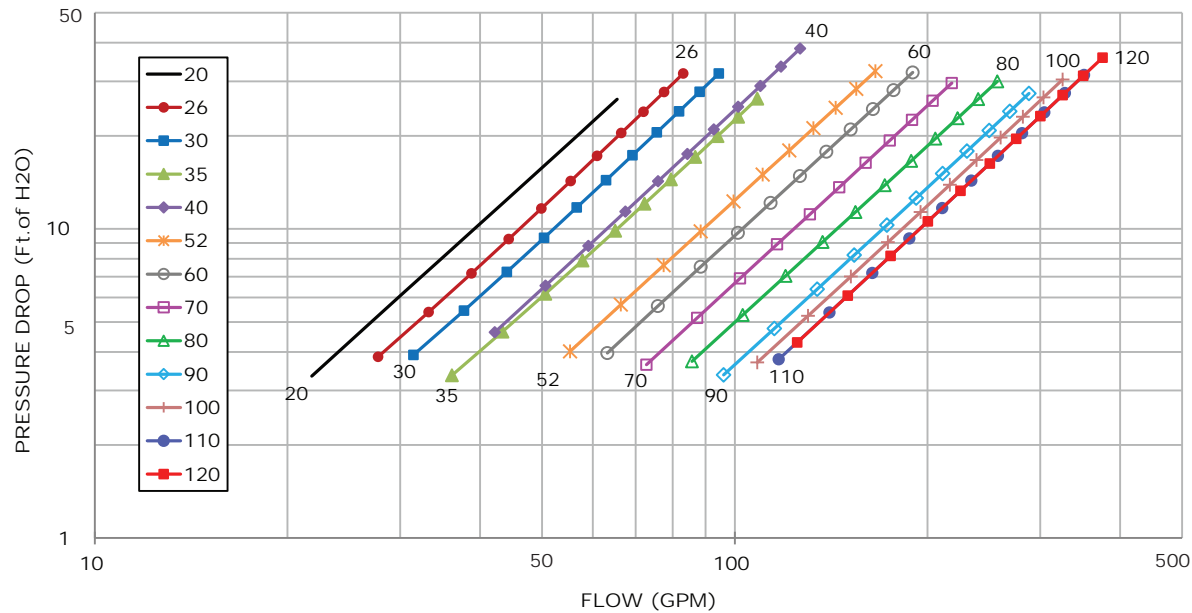

Figure 34. Total unit pressure drop curves (50 Hz)



Ambient Freeze Avoidance

Note: CGAM chillers use brazed plate heat exchanges, which are NOT at risk for refrigerant migration freeze. Chiller must only be protected from freeze due to low ambient conditions.

One or more of the ambient freeze avoidance methods in [Table 47](#) must be used to protect the CGAM chiller from ambient freeze damage.

Table 47. CGAM ambient freeze avoidance methods

Method	Protects to ambient temperature	Notes
Water pump control	Down to 0°F	<ul style="list-style-type: none"> CH530 controller can start the pump when the ambient temperatures drops to prevent freezing. For this option the pump must to be controlled by the CGAM unit and this function must be validated. Water circuit valves need to stay open at all times. If dual high head pump package option is selected, the chiller MUST control the pumps.
Heaters	Down to -20°F	<ul style="list-style-type: none"> This option is not applicable for units ordered with "No Freeze Protection" (model number digit 18 = X). Factory mounted heaters are NOT installed on these units, and one of the other forms of freeze protection must be used. For units with freeze protection selected (model number digit 18 is "1"), heaters are factory-installed on the evaporator and water piping and will protect them from freezing in ambient temperatures down to -20°F (-29°C). Install heat tape on all water piping, pumps, and other components that may be damaged if exposed to freezing temperatures. Heat tape must be designed for low ambient temperature applications. Heat tape selection should be based on the lowest expected ambient temperature. See NOTICE below for important information.
Freeze Inhibitor	Varies. See "Low Evap Refrigerant Cutout/Percent Glycol Recommendations," p. 69	<ul style="list-style-type: none"> Freeze protection can be accomplished by adding sufficient glycol to protect against freezing below the lowest ambient expected.
Drain Water Circuit	Below -20°F	<ul style="list-style-type: none"> Shut off the power supply to the unit and to all heaters. Purge the water circuit. Blow out the evaporator to ensure no liquid is left in the evaporator. By default the CH530 freeze protection control is enabled and will request the start of the chilled water pump with ambient temperatures less than the evaporator low leaving water temperature setpoint. The pump remains ON until the minimum evaporator water temperature is greater than low leaving water temperature setpoint plus 7°C. The minimum on time for the pump is 5 minutes. If you do NOT want the CH530 to start the pump when the ambient temperature drops to freezing, disable this freeze protection control.

NOTICE:

Equipment Damage!

All heaters have separate power from the unit. All heaters must be energized or the CH530 must control the pumps when the unit is off (unless the water circuit is drained or sufficient glycol is used). In the event of prolonged power loss, neither heaters nor CH530 control of the pumps will protect the evaporator from catastrophic damage. In order to provide freeze protection in the event of a power loss you MUST drain the evaporator, use sufficient freeze inhibitor in the evaporator or provide back-up power for pump.

Low Evap Refrigerant Cutout/Percent Glycol Recommendations

The table below shows the low evaporator temperature cutout for different glycol levels.

Additional glycol beyond the recommendations will adversely effect unit performance. The unit efficiency will be reduced and the saturated evaporator temperature will be reduced. For some operating conditions this effect can be significant.

If additional glycol is used, then use the actual percent glycol to establish the low refrigerant cutout setpoint.



Installation - Mechanical

Table 48. Low evap refrigerant temp cutout and low water temp cutout — ethylene glycol

% Glycol	Solution Freeze Point(°F)	Low Refrig Temp Cutout (°F)	Low Water Temp Cutout (°F)	FLOW >= 1.2 GPM/TON			FLOW >= 1.5 GPM/TON		
				Min Chilled Water Setpoint (°F)			Min Chilled Water Setpoint(°F)		
				Number of compressors			Number of compressors		
				2	4	6	2	4	6
0	32	22	36	42	42	42	41	40	40
1	31.6	21.6	35.6	42	40.1	39.2	40.6	39.1	38.6
2	31.0	21.0	35.0	42	39.5	38.6	40.0	38.5	38.0
3	30.3	20.3	34.3	41.3	38.8	38.0	39.3	37.8	37.3
4	29.7	19.7	33.7	40.7	38.2	37.3	38.7	37.2	36.7
5	29.0	19.0	33.0	40.0	37.5	36.7	38.0	36.5	36.0
6	28.3	18.3	32.3	39.3	36.8	36.0	37.3	35.8	35.3
7	27.6	17.6	31.6	38.6	36.1	35.3	36.6	35.1	34.6
8	26.9	16.9	30.9	37.9	35.4	34.6	35.9	34.4	33.9
9	26.2	16.2	30.2	37.2	34.7	33.9	35.2	33.7	33.2
10	25.5	15.5	29.5	36.5	34.0	33.1	34.5	33.0	32.5
11	24.7	14.7	28.7	35.7	33.2	32.4	33.7	32.2	31.7
12	23.9	13.9	27.9	34.9	32.4	31.6	32.9	31.4	30.9
13	23.1	13.1	27.1	34.1	31.6	30.8	32.1	30.6	30.1
14	22.3	12.3	26.3	33.3	30.8	30.0	31.3	29.8	29.3
15	21.5	11.5	25.5	32.5	30.0	29.1	30.5	29.0	28.5
16	20.6	10.6	24.6	31.6	29.1	28.2	29.6	28.1	27.6
17	19.7	9.7	23.7	30.7	28.2	27.3	28.7	27.2	26.7
18	18.7	8.7	22.7	29.7	27.2	26.4	27.7	26.2	25.7
19	17.8	7.8	21.8	28.8	26.3	25.5	26.8	25.3	24.8
20	16.8	6.8	20.8	27.8	25.3	24.5	25.8	24.3	23.8
21	15.8	5.8	19.8	26.8	24.3	23.5	24.8	23.3	22.8
22	14.7	4.7	18.7	25.7	23.2	22.4	23.7	22.2	21.7
23	13.7	3.7	17.7	24.7	22.2	21.3	22.7	21.2	20.7
24	12.5	2.5	16.5	23.5	21.0	20.2	21.5	20.0	19.5
25	11.4	1.4	15.4	22.4	19.9	19.1	20.4	18.9	18.4
26	10.2	0.2	14.2	21.2	18.7	17.9	19.2	17.7	17.2
27	9.0	-1.0	13.0	20.0	17.5	16.7	18.0	16.5	16.0
28	7.7	-2.3	11.7	18.7	16.2	15.4	16.7	15.2	14.7
29	6.4	-3.6	10.4	17.4	14.9	14.1	15.4	13.9	13.4
30	5.1	-4.9	9.1	16.1	13.6	12.8	14.1	12.6	12.1
31	3.7	-6.3	7.7	14.7	12.2	11.4	12.7	11.2	10.7
32	2.3	-7.7	6.3	13.3	10.8	9.9	11.3	9.8	9.3
33	0.8	-9.2	4.8	11.8	9.3	8.5	9.8	8.3	7.8
34	-0.7	-10.7	3.3	10.3	7.8	7.0	8.3	6.8	6.3
35	-2.3	-12.3	1.7	8.7	6.2	5.4	6.7	5.2	4.7
36	-3.9	-13.9	0.1	7.1	4.6	3.8	5.1	3.6	3.1
37	-5.6	-15.6	-1.6	5.4	2.9	2.1	3.4	1.9	1.4
38	-7.3	-17.3	-3.3	3.7	1.2	0.4	1.7	0.2	0.0
39	-9.0	-19.0	-5.0	2.0	0.0	0.0	0.0	0.0	0.0
40	-10.8	-20.8	-6.8	0.2	0.0	0.0	0.0	0.0	0.0

Table 48. Low evap refrigerant temp cutout and low water temp cutout — ethylene glycol (continued)

% Glycol	Solution Freeze Point(°F)	Low Refrig Temp Cutout (°F)	Low Water Temp Cutout (°F)	FLOW >= 1.2 GPM/TON			FLOW >= 1.5 GPM/TON		
				Min Chilled Water Setpoint (°F)			Min Chilled Water Setpoint(°F)		
				Number of compressors			Number of compressors		
				2	4	6	2	4	6
41	-12.7	-21.0	-7.0	0.0	0.0	0.0	0.0	0.0	0.0
42	-14.6	-21.0	-7.0	0.0	0.0	0.0	0.0	0.0	0.0
43	-16.6	-21.0	-7.0	0.0	0.0	0.0	0.0	0.0	0.0
44	-18.6	-21.0	-7.0	0.0	0.0	0.0	0.0	0.0	0.0
45	-20.7	-21.0	-7.0	0.0	0.0	0.0	0.0	0.0	0.0
46	-22.9	-21.0	-7.0	0.0	0.0	0.0	0.0	0.0	0.0
47	-25.1	-21.0	-7.0	0.0	0.0	0.0	0.0	0.0	0.0
48	-27.3	-21.0	-7.0	0.0	0.0	0.0	0.0	0.0	0.0
49	-29.7	-21.0	-7.0	0.0	0.0	0.0	0.0	0.0	0.0
50	-32.1	-21.0	-7.0	0.0	0.0	0.0	0.0	0.0	0.0
51	-34.5	-21.0	-7.0	0.0	0.0	0.0	0.0	0.0	0.0
52	-37.1	-21.0	-7.0	0.0	0.0	0.0	0.0	0.0	0.0
53	-39.7	-21.0	-7.0	0.0	0.0	0.0	0.0	0.0	0.0
54	-42.3	-21.0	-7.0	0.0	0.0	0.0	0.0	0.0	0.0
55	-45.0	-21.0	-7.0	0.0	0.0	0.0	0.0	0.0	0.0

Table 49. Low evap refrigerant temp cutout and low water temp cutout — propylene glycol

% Glycol	Solution Freeze Point(°F)	Low Refrig Temp Cutout (°F)	Low Water Temp Cutout (°F)	FLOW >= 1.2 GPM/TON			FLOW >= 1.5 GPM/TON		
				Min Chilled Water Setpoint (°F)			Min Chilled Water Setpoint(°F)		
				Number of compressors			Number of compressors		
				2	4	6	2	4	6
0	32	22	36	42	42	42	41	40	40
1	31.6	21.6	35.6	42	40.1	39.2	40.6	39.1	38.6
2	31.0	21.0	35.0	42	39.5	38.7	40.0	38.5	38.0
3	30.4	20.4	34.4	41.4	38.9	38.1	39.4	37.9	37.4
4	29.9	19.9	33.9	40.9	38.4	37.5	38.9	37.4	36.9
5	29.3	19.3	33.3	40.3	37.8	37.0	38.3	36.8	36.3
6	28.7	18.7	32.7	39.7	37.2	36.4	37.7	36.2	35.7
7	28.1	18.1	32.1	39.1	36.6	35.8	37.1	35.6	35.1
8	27.6	17.6	31.6	38.6	36.1	35.2	36.6	35.1	34.6
9	27.0	17.0	31.0	38.0	35.5	34.6	36.0	34.5	34.0
10	26.4	16.4	30.4	37.4	34.9	34.0	35.4	33.9	33.4
11	25.7	15.7	29.7	36.7	34.2	33.4	34.7	33.2	32.7
12	25.1	15.1	29.1	36.1	33.6	32.8	34.1	32.6	32.1
13	24.4	14.4	28.4	35.4	32.9	32.1	33.4	31.9	31.4
14	23.8	13.8	27.8	34.8	32.3	31.4	32.8	31.3	30.8
15	23.1	13.1	27.1	34.1	31.6	30.7	32.1	30.6	30.1
16	22.4	12.4	26.4	33.4	30.9	30.0	31.4	29.9	29.4
17	21.6	11.6	25.6	32.6	30.1	29.3	30.6	29.1	28.6
18	20.9	10.9	24.9	31.9	29.4	28.5	29.9	28.4	27.9
19	20.1	10.1	24.1	31.1	28.6	27.8	29.1	27.6	27.1
20	19.3	9.3	23.3	30.3	27.8	26.9	28.3	26.8	26.3



Installation - Mechanical

Table 49. Low evap refrigerant temp cutout and low water temp cutout — propylene glycol (continued)

% Glycol	Solution Freeze Point(°F)	Low Refrig Temp Cutout (°F)	Low Water Temp Cutout (°F)	FLOW >= 1.2 GPM/TON			FLOW >= 1.5 GPM/TON		
				Min Chilled Water Setpoint (°F)			Min Chilled Water Setpoint(°F)		
				Number of compressors			Number of compressors		
				2	4	6	2	4	6
21	18.4	8.4	22.4	29.4	26.9	26.1	27.4	25.9	25.4
22	17.6	7.6	21.6	28.6	26.1	25.2	26.6	25.1	24.6
23	16.7	6.7	20.7	27.7	25.2	24.3	25.7	24.2	23.7
24	15.7	5.7	19.7	26.7	24.2	23.4	24.7	23.2	22.7
25	14.8	4.8	18.8	25.8	23.3	22.4	23.8	22.3	21.8
26	13.8	3.8	17.8	24.8	22.3	21.4	22.8	21.3	20.8
27	12.7	2.7	16.7	23.7	21.2	20.4	21.7	20.2	19.7
28	11.6	1.6	15.6	22.6	20.1	19.3	20.6	19.1	18.6
29	10.5	0.5	14.5	21.5	19.0	18.2	19.5	18.0	17.5
30	9.3	-0.7	13.3	20.3	17.8	17.0	18.3	16.8	16.3
31	8.1	-1.9	12.1	19.1	16.6	15.8	17.1	15.6	15.1
32	6.8	-3.2	10.8	17.8	15.3	14.5	15.8	14.3	13.8
33	5.5	-4.5	9.5	16.5	14.0	13.2	14.5	13.0	12.5
34	4.1	-5.9	8.1	15.1	12.6	11.8	13.1	11.6	11.1
35	2.7	-7.3	6.7	13.7	11.2	10.4	11.7	10.2	9.7
36	1.3	-8.7	5.3	12.3	9.8	8.9	10.3	8.8	8.3
37	-0.3	-10.3	3.7	10.7	8.2	7.4	8.7	7.2	6.7
38	-1.8	-11.8	2.2	9.2	6.7	5.8	7.2	5.7	5.2
39	-3.5	-13.5	0.5	7.5	5.0	4.2	5.5	4.0	3.5
40	-5.2	-15.2	-1.2	5.8	3.3	2.5	3.8	2.3	1.8
41	-6.9	-16.9	-2.9	4.1	1.6	0.7	2.1	0.6	0.1
42	-8.8	-18.8	-4.8	2.2	0.0	0.0	0.2	0.0	0.0
43	-10.7	-20.7	-6.7	0.3	0.0	0.0	0.0	0.0	0.0
44	-12.6	-21.0	-7.0	0.0	0.0	0.0	0.0	0.0	0.0
45	-14.6	-21.0	-7.0	0.0	0.0	0.0	0.0	0.0	0.0
46	-16.7	-21.0	-7.0	0.0	0.0	0.0	0.0	0.0	0.0
47	-18.9	-21.0	-7.0	0.0	0.0	0.0	0.0	0.0	0.0
48	-21.1	-21.0	-7.0	0.0	0.0	0.0	0.0	0.0	0.0
49	-23.4	-21.0	-7.0	0.0	0.0	0.0	0.0	0.0	0.0
50	-25.8	-21.0	-7.0	0.0	0.0	0.0	0.0	0.0	0.0
51	-28.3	-21.0	-7.0	0.0	0.0	0.0	0.0	0.0	0.0
52	-30.8	-21.0	-7.0	0.0	0.0	0.0	0.0	0.0	0.0
53	-33.4	-21.0	-7.0	0.0	0.0	0.0	0.0	0.0	0.0
54	-36.1	-21.0	-7.0	0.0	0.0	0.0	0.0	0.0	0.0
55	-38.9	-21.0	-7.0	0.0	0.0	0.0	0.0	0.0	0.0

Performance Adjustment Factors

Concentration and type of glycol used will affect unit performance. If operating conditions, including concentration of freeze inhibitor, have changed since the unit was ordered, contact sales representative to rerun selection. See [Figure 35, p. 73](#) through [Figure 40, p. 73](#) for approximate adjustment factors.

Figure 35. Ethylene - compressor power adjustment

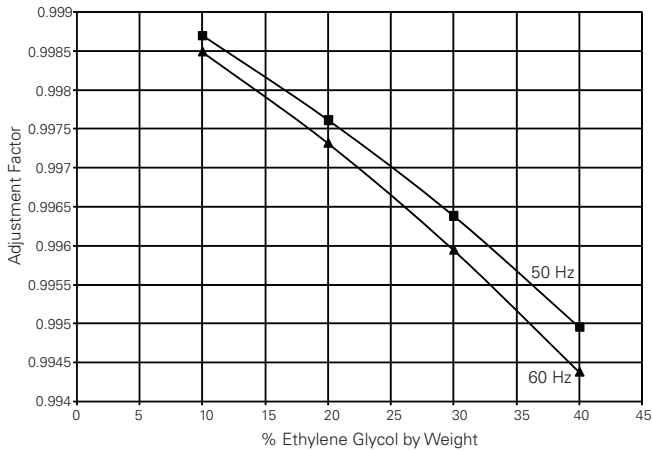

Figure 36. Propylene - compressor power adjustment

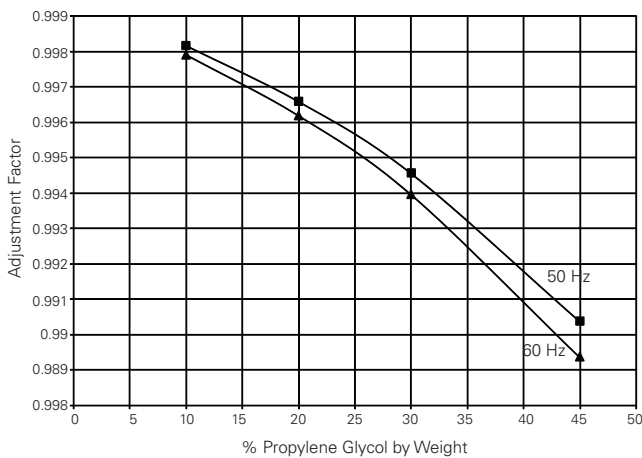

Figure 37. Ethylene - GPM adjustment

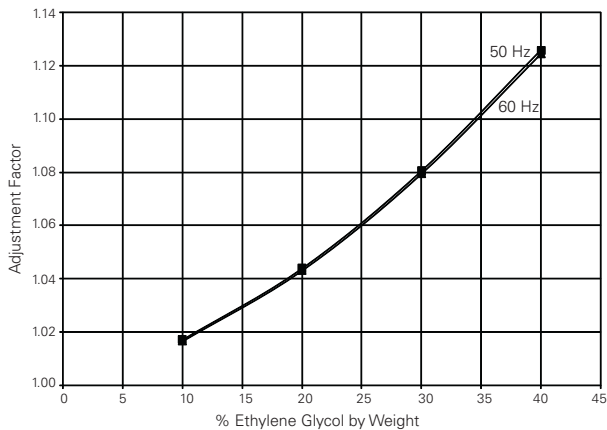

Figure 38. Propylene - GPM adjustment

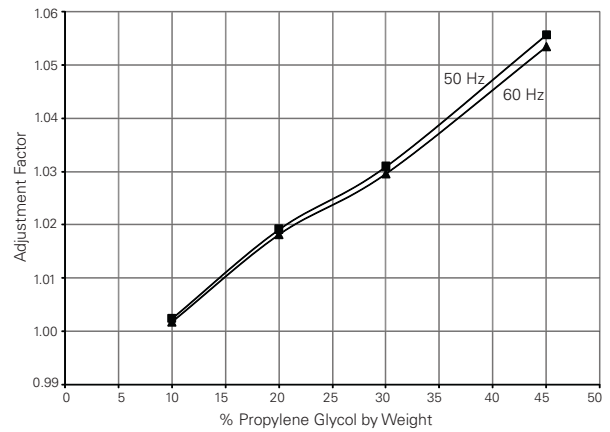

Figure 39. Ethylene - capacity adjustment

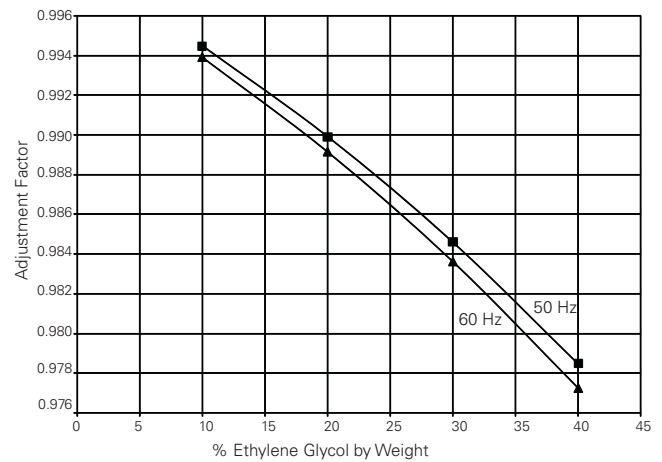
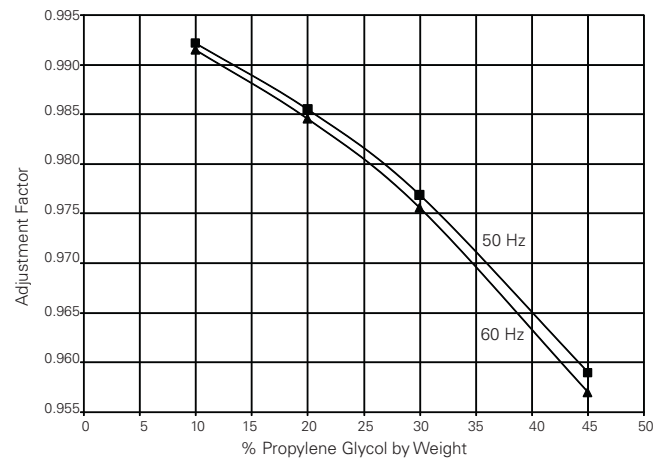

Figure 40. Propylene - capacity adjustment





Partial Heat Recovery

The partial heat recovery is comprised of an auxiliary heat exchanger installed in the discharge line between the compressor and the air -cooled condenser. The heat exchanger cools compressor discharge gas and rejects the energy to a separate water loop for hot water applications. The chiller can simultaneously produce chilled and hot water.

The heating capacity is driven by the cooling demand on the chiller, the condensing temperature and the flow rate through the heat exchanger.

The partial heat recovery includes:

- Brazed plate heat exchanger
 - Units 20-35 Tons have a single braze plate heat exchanger. Units 40-130 Tons have two braze plate heat exchangers in parallel arrangement.
- Piping between the heat exchanger(s)
- Insulation of the heat exchanger(s) and water pipe
- Two temperature sensors to read the inlet/outlet hot water temperature information on the unit control display
- Heater on partial heat recovery heat exchanger(s) and water pipe
- Manual air vent
- Drain pipe

Water circulating inside the heat recovery heat exchanger should never be used for drinking water, it must be used through an indirect loop to heat or preheat hot water.

Important: *The installation must comply with the rules and legislation applicable at the jobsite location regarding the use of drinkable water. The use of the water circulating in the heat recovery exchanger as drinkable water is not recommended. An intermediate heat exchanger should be used.*

The partial heat recovery pump must run at least three minutes after the partial heat recovery fan control is disabled. During the three minutes, water flow through the brazed plate heat exchanger will gradually be reduced and the unit can be switched to conventional cooling mode without partial heat recovery fan control.

NOTICE:

Equipment Damage!

If the partial heat recovery heat exchanger is drained the heater must be turned off to avoid damaging the partial heater recovery heat exchanger. The heater should only be on when the heat recovery heat exchanger has water in it.

Partial Heat Recovery Piping

A field installed safety or relief valve on the water side is required with the partial heat recovery to prevent risks resulting from a failure of the thermostat.

A 16 mesh strainer must be installed close to the partial heat recovery heat exchanger entering water line to protect the heat exchanger.

The partial heat recovery water temperature should be controlled via an external device such as a 3-way valve or variable speed pump. In addition, a water tank and additional heater is suggested in the partial heat recovery loop.

Insulate water lines and other portions of the heat recovery water loop to prevent heat loss and potential injury due exposure to a hot surface.

For recommended partial heat recovery piping see [Figure 41, p. 75](#).

NOTICE:

Proper Water Treatment!

The use of untreated or improperly treated water could result in scaling, erosion, corrosion, algae or slime. It is recommended that the services of a qualified water treatment specialist be engaged to determine what water treatment, if any, is required. Trane assumes no responsibility for equipment failures which result from untreated or improperly treated water, or saline or brackish water.

NOTICE:

Equipment Damage!

Do not use untreated or improperly treated water in the heat recovery water loop as it could damage to the unit. It will also cause inefficient operation and potential damage to the unit such as reduced heat transfer between water and refrigerant, increased water pressure drop and reduced water flow.

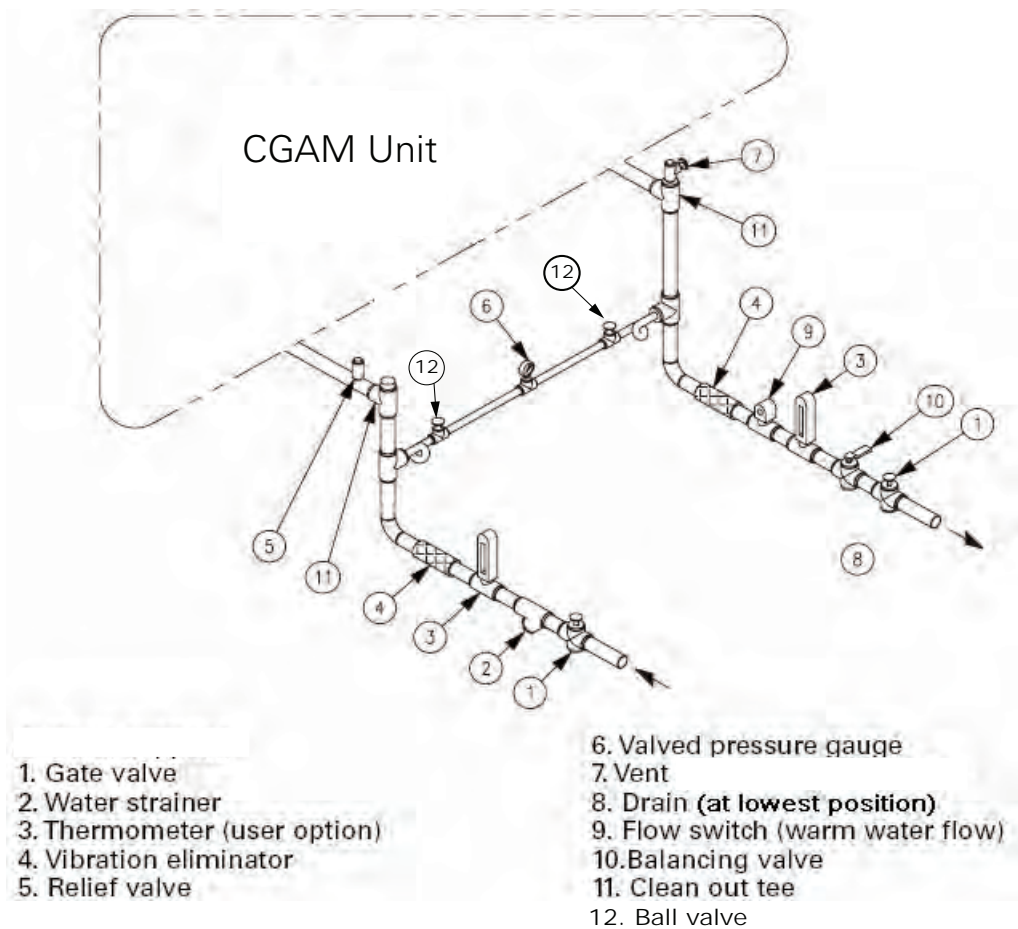
Figure 41. Partial heat recovery piping recommendations

Note: In addition to those recommended for field piping, the CGAM unit includes factory installed manual air vent and water drain valve with partial heat recovery option. See [“Partial Heat Recovery Components,” p. 100](#) for locations.

Partial Heat Recovery Freeze Avoidance

The heat recovery condenser is insulated and a factory-installed heater is installed and will protect the heat exchanger from freezing in ambient temperatures down to -20°F (-29°C).

When the ambient temperature drops to approximately 39°F (3.9°C) the thermostat energizes the heaters.

Note: The inlet and outlet piping should be protected against freezing by one of the following methods:

- Install heat tape on all field-installed water piping.

OR

- Add freeze inhibiting fluid to the partial heat recovery water loop.



Partial Heat Recovery Pressure Drop Curves

Figure 42. Partial heat recovery pressure drop curve – 60 Hz

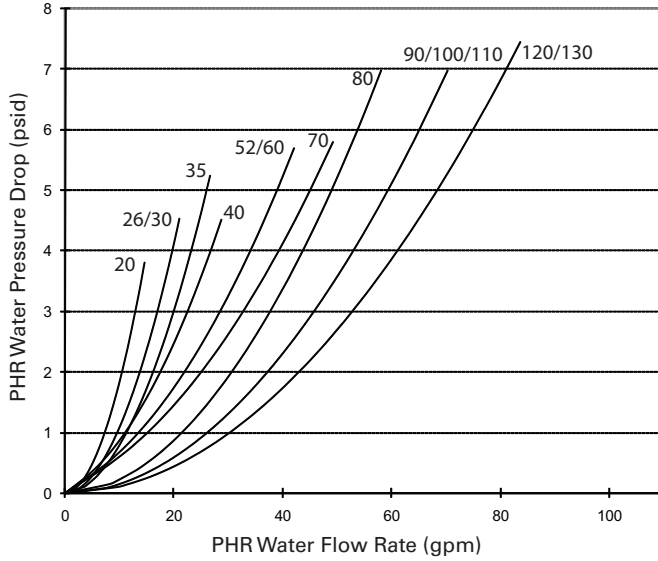

Figure 43. Partial heat recovery pressure drop curve – 50 Hz

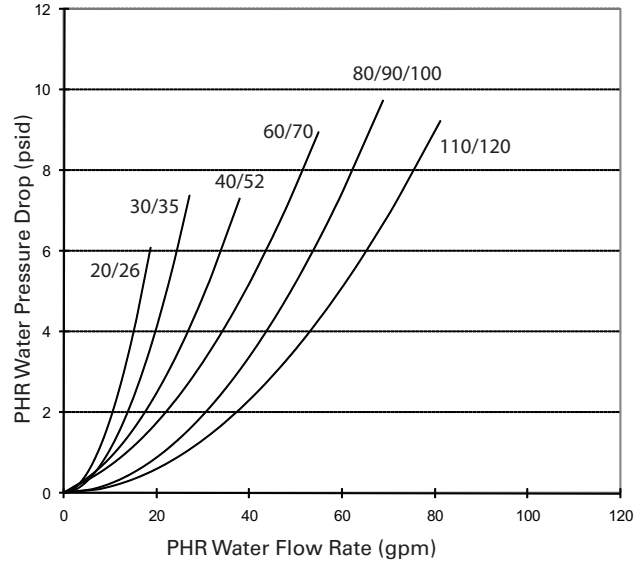

Table 50. Partial heat recovery flow rates – 60 Hz

Size		20	26	30	35	40	52	60	70	80	90	100	110	120	130
Nominal Flow Rate ^(a)	(gpm)	13	19	18	24	26	39	37	50	46	59	61	70	83	79
Maximum Flow Rate	(gpm)	39	39	39	39	79	79	79	79	127	127	127	127	127	127

(a) Water temperature inlet 122°F, outlet 131°F

Table 51. Partial heat recovery flow rates – 50 Hz

Size		20	26	30	35	40	52	60	70	80	90	100	110	120	130
Nominal Flow Rate ^(a)	(gpm)	11	15	16	20	21	30	32	40	39	47	48	58	65	11
Maximum Flow Rate	(gpm)	39	39	39	39	79	79	79	79	127	127	127	127	127	39

(a) Water temperature inlet 122°F, outlet 131°F

Note: Partial heat recovery may function at flow rates near zero. However, heat transfer performance is severely reduced and water flow distribution is poor.

Dual High Head Pump Package

Pump package includes: two high head pumps, VFD, expansion vessels, drainage valves, shut-off valves at entering and leaving connections. See Figure 45.

The pump package is single point power integrated into the chiller unit power with a separate factory wired control panel. The control of the pump is integrated into the chiller controller.

Important: When pump package is selected, the chiller **MUST** control the pumps.

The CH530 displays evaporator pump starts and run-times. Freeze protection down to an ambient of -20°F (-29°C) is included as standard. The cold parts of the pump package will also be insulated. Designed with one redundant pump, the chiller controls both pumps through a lead/lag and failure/recovery functionality.

A variable speed drive is installed in an additional panel to control the pump. The inverter should be adjusted by the customer upon start up to balance the system flow and head requirements. The purpose is to save on wasted pump energy caused by a traditional balancing valve.

Note: Speed command is also available for customer-provided variable flow input.

Figure 44. Field water piping pump package unit

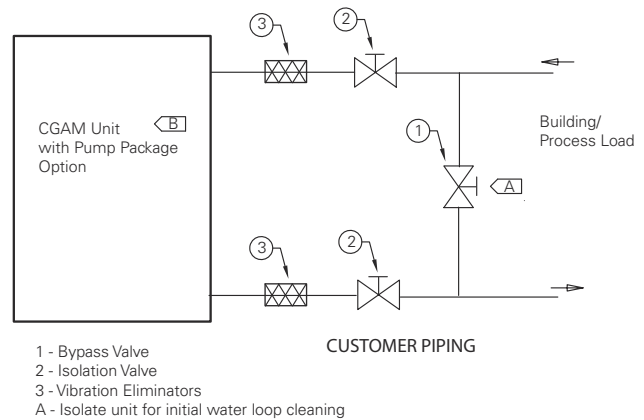

Table 52. Field water piping components — unit with pump package option

Item	Description
1	Bypass Valve
2	Isolator Valve
3	Vibration Eliminator
A	Isolate unit for initial water loop cleaning
B	See Figure 45 for CGAM pump package unit schematic.

Figure 45. Pump package unit schematic

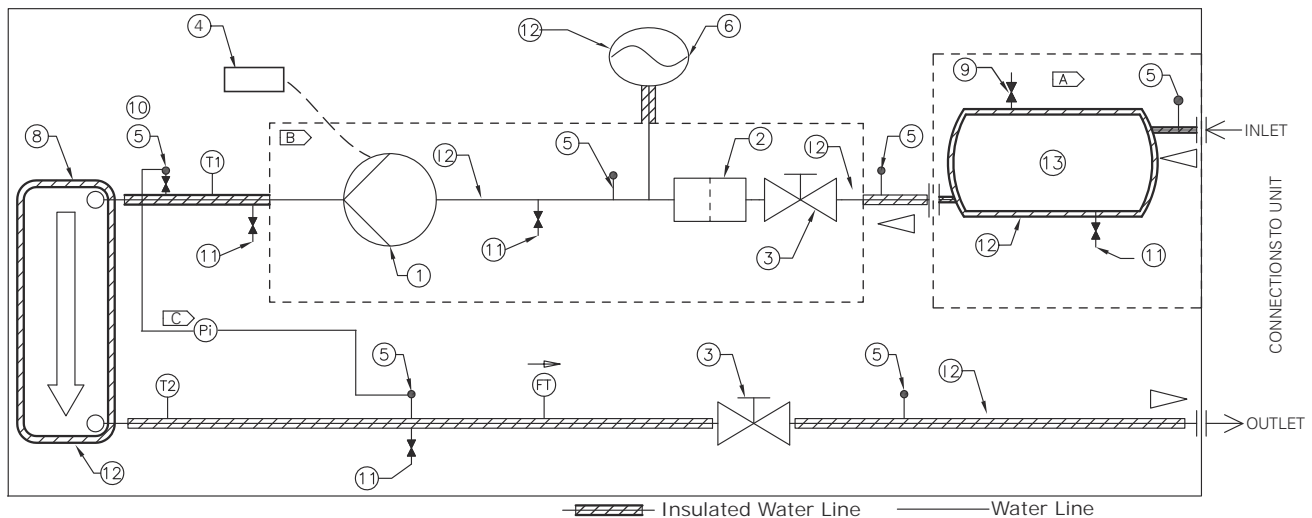

Table 53. Pump package components

Item	Description	Item	Description	Item	Description
1	Centrifugal Pump (Dual pumps std)	9	Automatic Air Vent	Pi	Gauge
2	Water Strainer	10	Manual Air Bleed	FT	Water Flow Switch
3	Butterfly Valve	11	Drain Valve	T1	Evap Water Inlet Temp Sensor
4	Inverter	12	Water Heater	T2	Evap Water Outlet Temp Sensor
5	Valve for Pressure Point	13	Buffer Tank (Optional)	A	Optional Buffer Tank
6	Expansion Tank			B	Insulated Pump Box
7	N/A			C	Brazed plate differential pressure gauge and piping not supplied. Must account for water head height difference when calculating brazed plate pressure differential.
8	Evaporator heat exchanger				



Pressure Drop Information - Units with Optional Pump Package

Water only

Factory Installed Pump Package - Pump Curves.

Figure 46 through Figure 49, p. 79 show manufacturer pump curves for factory-installed pump package.

Figure 46. Pump curve, 20 to 52 ton units, water only

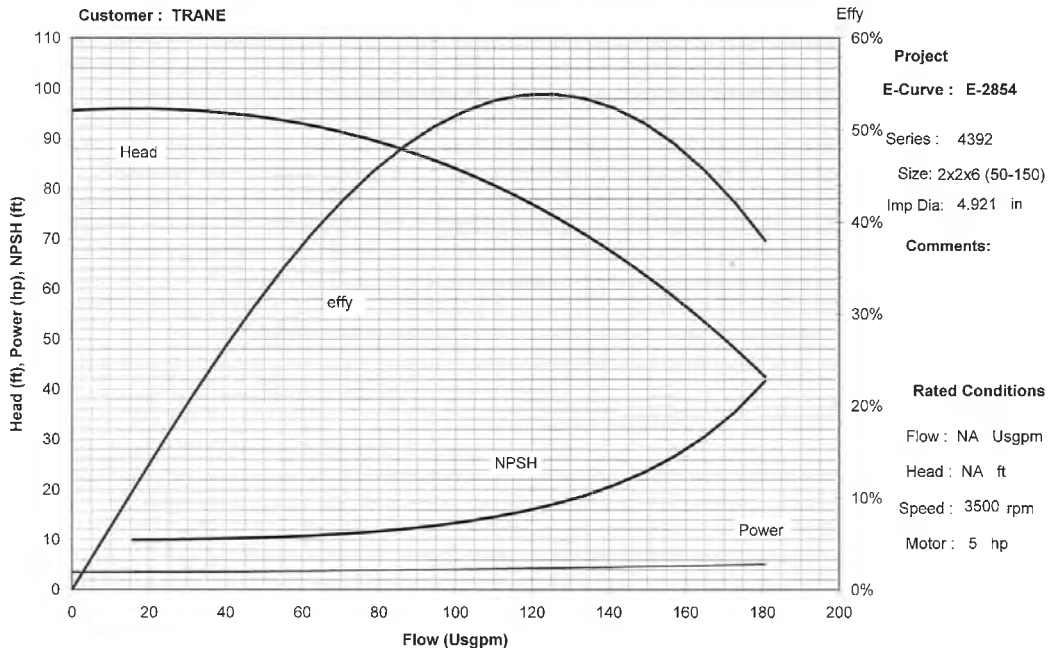

Figure 47. Pump curve, 60 to 70 ton units, water only

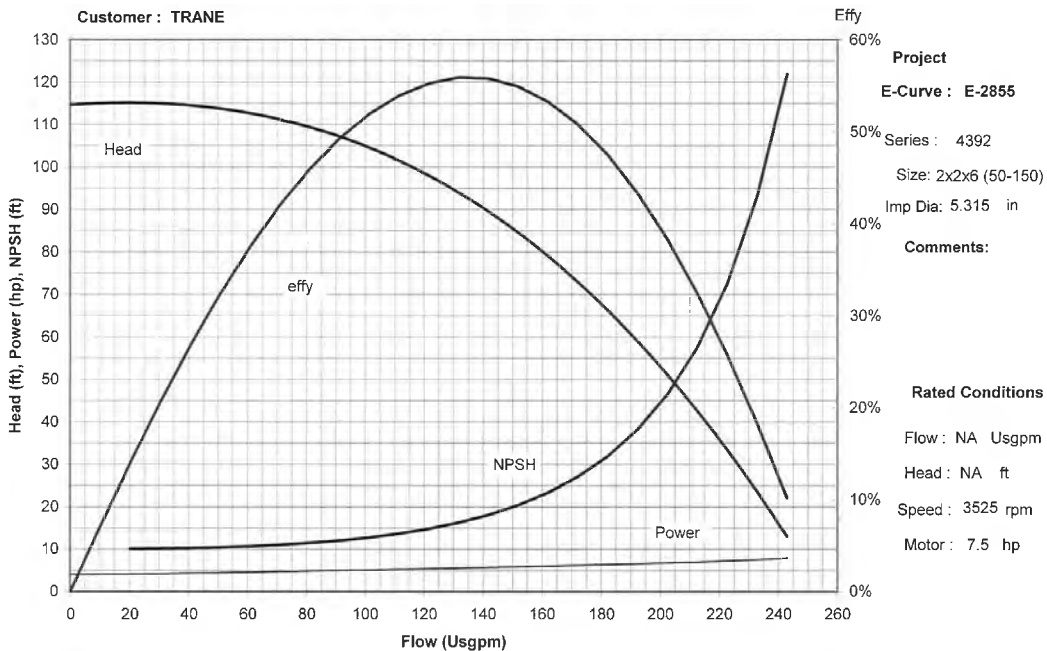

Figure 48. Pump curve, 80 to 110 ton units, water only

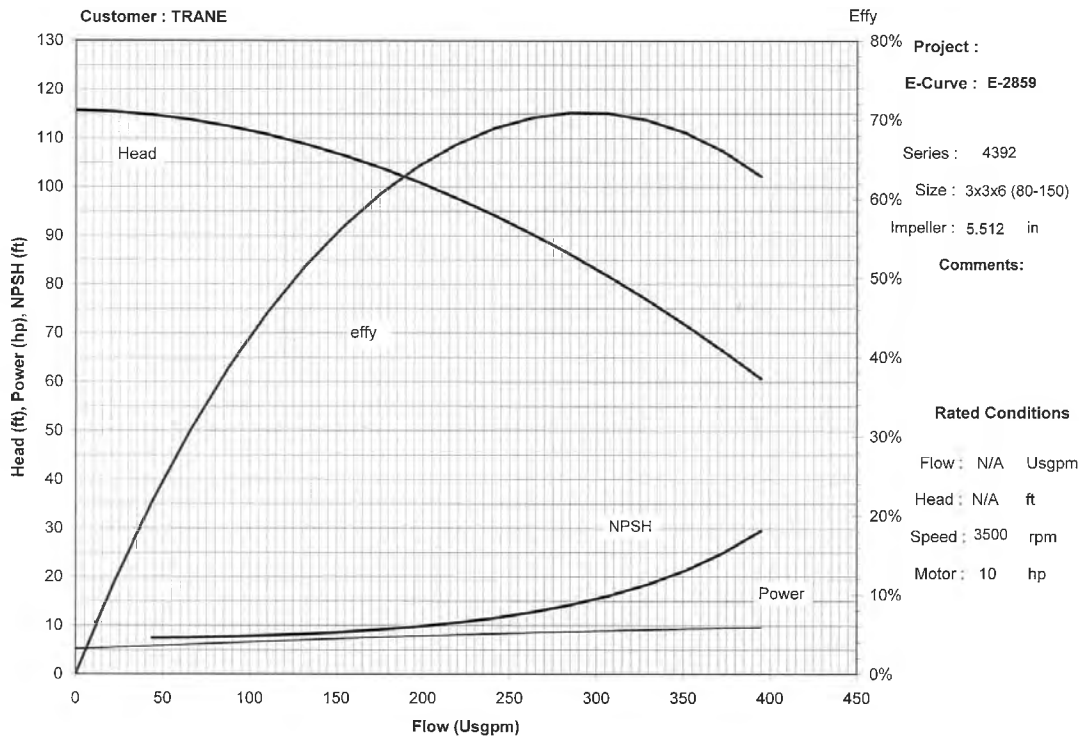
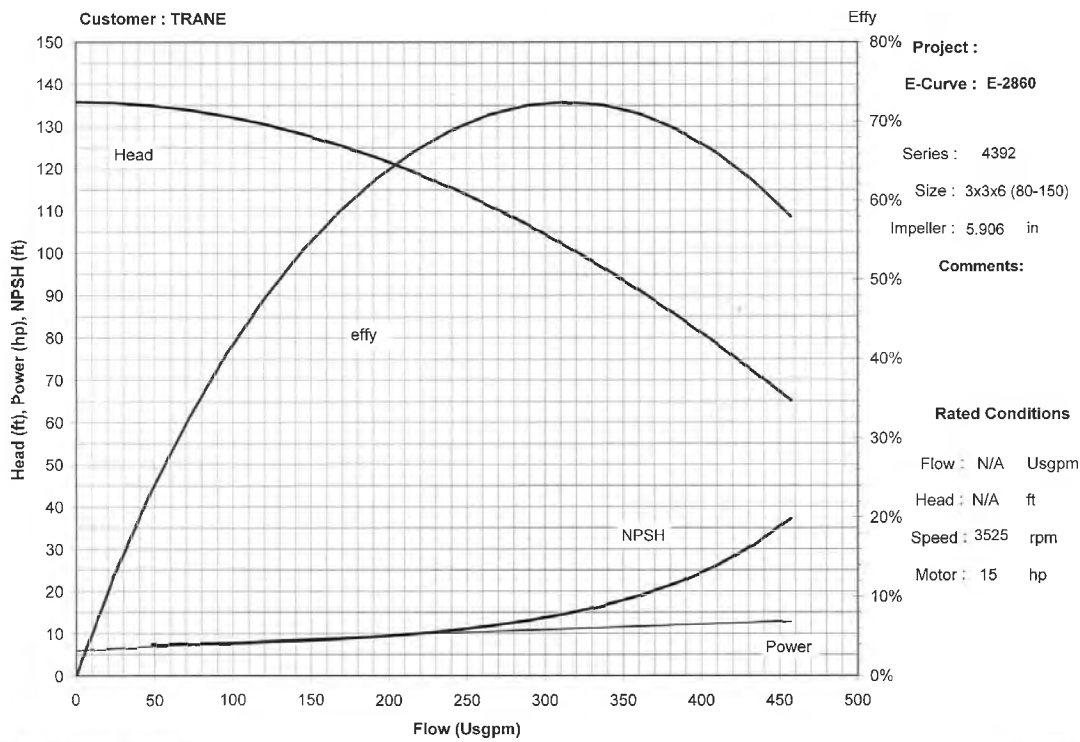

Figure 49. Pump curve, 120 to 130 ton units, water only





Installation - Mechanical

Unit Component Pressure Drop. Figure 50 shows the pressure drop values for unit components, including evaporator, strainer, piping and valves.

Figure 50. Unit component pressure drop, water only

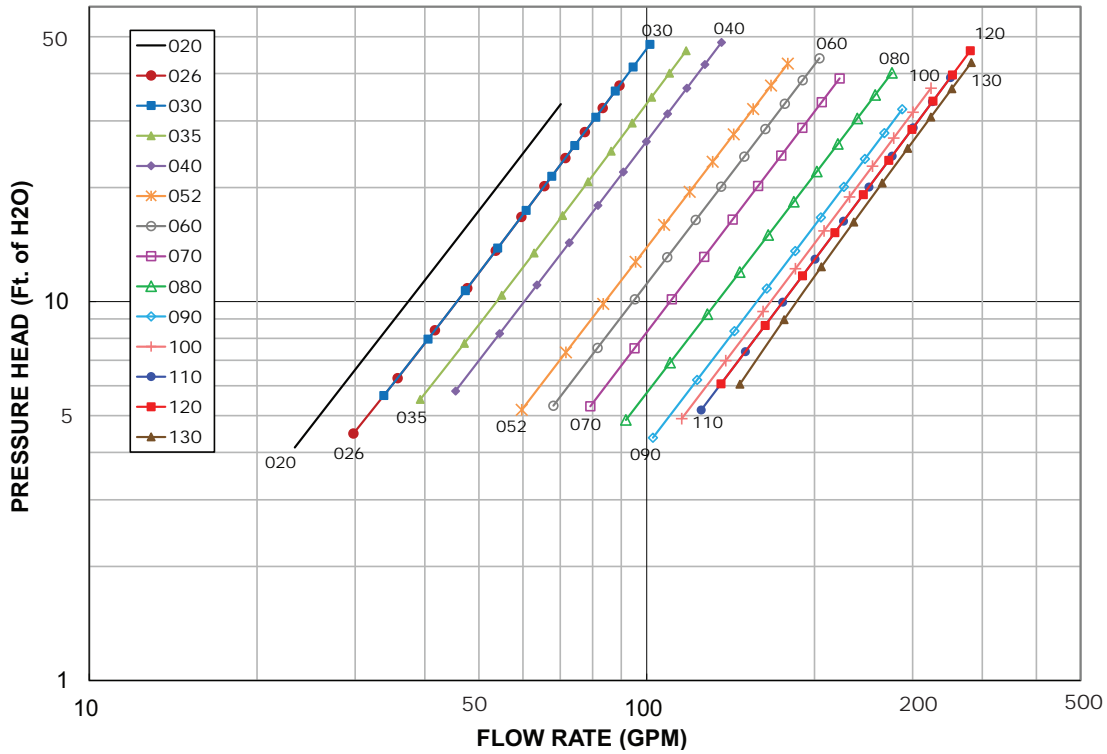

System Head Pressure. See Figure 51 for the system head pressure available.

Note: System Head Pressure = Pump Pressure - Component Pressure)

Figure 51. CGAM pump package available head pressure, water only

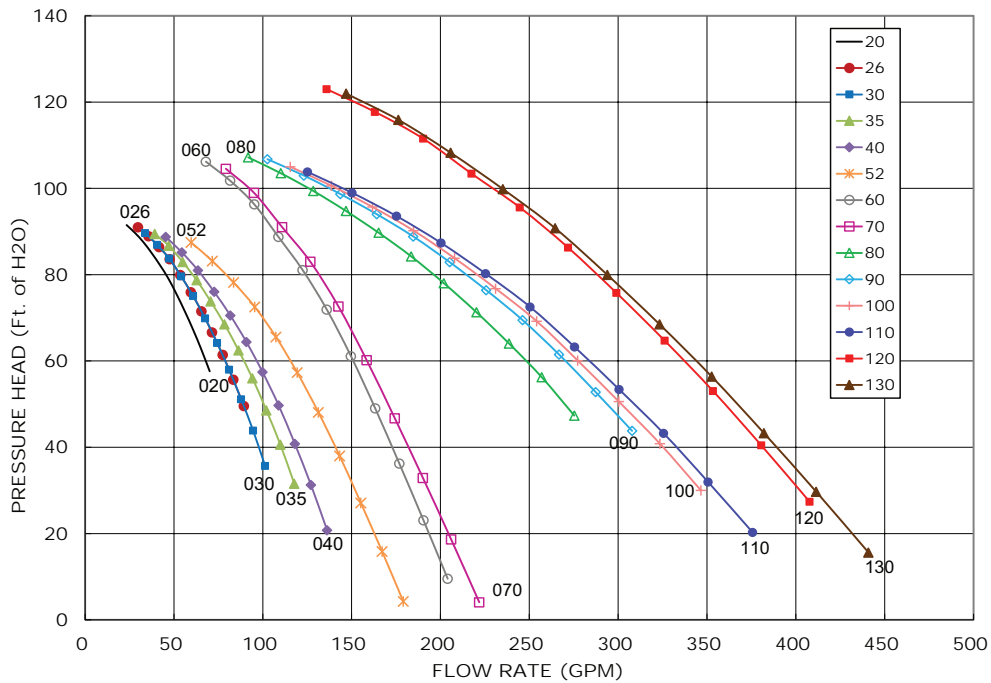

Unit with Optional Pump Package Systems - Glycol

If using glycol in system, apply adjustment factors to pressure drops per the following formulas:

- Glycol Pump Head =
Water Pump Head x Pump Adjustment Factor
- Glycol Component Pressure Drop =
Components Pressure Drop x Component Adjustment Factor

Note:

- For Water Pump Head, see [Figure 46, p. 78](#) through [Figure 49, p. 79](#)
- For Component Pressure Drop, see [Figure 50, p. 80](#)
- For Pump and Component Adjustment Factors, see [Table 54](#)

Table 54. Brine adjustment factors

Percentage Glycol	Ethylene Glycol Adjustment for		Propylene Glycol Adjustment for	
	Pump	Components	Pump	Components
5%	1.004	1.085	1.004	1.165
10%	1.009	1.120	1.009	1.200
15%	1.015	1.155	1.015	1.235
20%	1.021	1.190	1.021	1.270
25%	1.028	1.235	1.028	1.300
30%	1.034	1.280	1.034	1.330
35%	1.040	1.345	1.040	1.365
40%	1.046	1.410	1.046	1.400
45%	-	-	1.051	1.460

Pump Package Requirements

The following requirements must be met for proper operation of pump package:

- Maximum working pressure 150 psig
- Fluid type shown in [Table 55](#)

Table 55. Working fluid

Fluid Type	Fluid Percent (of weight)
Water	100%
Ethylene Glycol	0-40%
Propylene Glycol	0-45%

- Customer pressure drop must not exceed pump package head pressures found in ["General Information," p. 10.](#)
- If buffer tank option is selected, customer water volume must not exceed the values in [Table 56, p. 82](#) and [Table 57, p. 83](#). User volume expansion capacity is defined as the additional expansion volume usable for the customer if the chiller is installed with pump package and buffer tank options.



Installation - Mechanical

Expansion Tank - Maximum Loop Volume

Expansion tanks supplied as part of the pump package option will allow loop expansion due to ambient fluctuations for maximum loop volumes shown in [Table 56](#) and [Table 57, p. 83](#).

Note: Negative values indicate that a field-installed tank is required to cover the expansion due to ambient fluctuations of the fluid in the chiller.

Important: Chilled waterside pressure relief valve is designed to open at 226 ft. If relief valve is opening at lower pressures, verify system has sufficient expansion tank volume for the water and/or glycol solution used.

Table 56. Maximum loop volume – gallons (external to the chiller)

Size	Maximum Ambient = 100°F										Maximum Ambient = 115°F									
	Water	% Ethylene Glycol				% Propylene Glycol					Water	% Ethylene Glycol				% Propylene Glycol				
		10	20	30	40	10	20	30	40	45		10	20	30	40	10	20	30	40	45
Without Buffer Tank																				
020	479	433	296	199	148	292	198	139	108	98	317	293	216	155	120	222	155	112	87	80
026	479	433	296	199	148	292	198	139	108	98	317	293	216	155	120	222	155	112	87	80
030	479	433	296	199	148	292	198	139	108	98	317	293	216	155	120	222	155	112	87	80
035	479	433	296	199	148	292	198	139	108	98	317	293	216	155	120	222	155	112	87	80
040	474	428	291	194	143	286	193	134	102	93	312	287	211	150	114	216	149	106	82	75
052	474	428	291	194	143	286	193	134	102	93	312	287	211	150	114	216	149	106	82	75
060	474	428	291	194	143	286	193	134	102	93	312	287	211	150	114	216	149	106	82	75
070	474	428	291	194	143	286	193	134	102	93	312	287	211	150	114	216	149	106	82	75
080	626	565	383	253	185	377	252	174	131	119	411	378	276	194	147	283	194	136	104	95
090	626	565	383	253	185	377	252	174	131	119	411	378	276	194	147	283	194	136	104	95
100	626	565	383	253	185	377	252	174	131	119	411	378	276	194	147	283	194	136	104	95
110	626	565	383	253	185	377	252	174	131	119	411	378	276	194	147	283	194	136	104	95
120	626	565	383	253	185	377	252	174	131	119	411	378	276	194	147	283	194	136	104	95
130	626	565	383	253	185	377	252	174	131	119	411	378	276	194	147	283	194	136	104	95
With Buffer Tank																				
020	335	289	152	55	4	148	54	-5	-36	-46	173	149	72	11	-24	78	11	-32	-57	-64
026	335	289	152	55	4	148	54	-5	-36	-46	173	149	72	11	-24	78	11	-32	-57	-64
030	335	289	152	55	4	148	54	-5	-36	-46	173	149	72	11	-24	78	11	-32	-57	-64
035	335	289	152	55	4	148	54	-5	-36	-46	173	149	72	11	-24	78	11	-32	-57	-64
040	338	292	155	58	7	150	57	-2	-34	-43	176	151	75	14	-22	80	13	-30	-54	-61
052	338	292	155	58	7	150	57	-2	-34	-43	176	151	75	14	-22	80	13	-30	-54	-61
060	338	292	155	58	7	150	57	-2	-34	-43	176	151	75	14	-22	80	13	-30	-54	-61
070	338	292	155	58	7	150	57	-2	-34	-43	176	151	75	14	-22	80	13	-30	-54	-61
080	470	409	226	97	29	220	96	17	-25	-38	254	221	119	38	-9	127	38	-20	-52	-62
090	470	409	226	97	29	220	96	17	-25	-38	254	221	119	38	-9	127	38	-20	-52	-62
100	425	364	181	52	-16	175	51	-28	-70	-83	210	177	74	-7	-54	82	-7	-65	-97	-107
110	425	364	181	52	-16	175	51	-28	-70	-83	210	177	74	-7	-54	82	-7	-65	-97	-107
120	425	364	181	52	-16	175	51	-28	-70	-83	210	177	74	-7	-54	82	-7	-65	-97	-107
130	425	364	181	52	-16	175	51	-28	-70	-83	210	177	74	-7	-54	82	-7	-65	-97	-107

Table 57. Maximum loop volume – liters (external to the chiller)

Size	Maximum Ambient = 100°F										Maximum Ambient = 115°F											
	Water	% Ethylene Glycol					% Propylene Glycol					Water	% Ethylene Glycol					% Propylene Glycol				
		10	20	30	40	45	10	20	30	40	45		10	20	30	40	45	10	20	30	40	45
Without Buffer Tank																						
020	1813	1639	1121	754	561	1104	751	528	407	372	1201	1108	818	587	453	839	586	422	331	303		
026	1813	1639	1121	754	561	1104	751	528	407	372	1201	1108	818	587	453	839	586	422	331	303		
030	1813	1639	1121	754	561	1104	751	528	407	372	1201	1108	818	587	453	839	586	422	331	303		
035	1813	1639	1121	754	561	1104	751	528	407	372	1201	1108	818	587	453	839	586	422	331	303		
040	1793	1619	1101	734	541	1084	731	508	387	352	1181	1088	798	567	433	819	566	402	311	283		
052	1793	1619	1101	734	541	1084	731	508	387	352	1181	1088	798	567	433	819	566	402	311	283		
060	1793	1619	1101	734	541	1084	731	508	387	352	1181	1088	798	567	433	819	566	402	311	283		
070	1793	1619	1101	734	541	1084	731	508	387	352	1181	1088	798	567	433	819	566	402	311	283		
080	2370	2139	1448	958	701	1426	955	657	496	449	1555	1430	1044	736	558	1072	735	516	394	358		
090	2370	2139	1448	958	701	1426	955	657	496	449	1555	1430	1044	736	558	1072	735	516	394	358		
100	2370	2139	1448	958	701	1426	955	657	496	449	1555	1430	1044	736	558	1072	735	516	394	358		
110	2370	2139	1448	958	701	1426	955	657	496	449	1555	1430	1044	736	558	1072	735	516	394	358		
120	2370	2139	1448	958	701	1426	955	657	496	449	1555	1430	1044	736	558	1072	735	516	394	358		
130	2370	2139	1448	958	701	1426	955	657	496	449	1555	1430	1044	736	558	1072	735	516	394	358		
With Buffer Tank																						
020	1268	1094	576	209	16	559	206	-17	-138	-173	656	563	273	42	-92	294	41	-123	-214	-242		
026	1268	1094	576	209	16	559	206	-17	-138	-173	656	563	273	42	-92	294	41	-123	-214	-242		
030	1268	1094	576	209	16	559	206	-17	-138	-173	656	563	273	42	-92	294	41	-123	-214	-242		
035	1268	1094	576	209	16	559	206	-17	-138	-173	656	563	273	42	-92	294	41	-123	-214	-242		
040	1278	1104	586	219	26	569	216	-7	-128	-163	666	573	283	52	-82	304	51	-113	-204	-232		
052	1278	1104	586	219	26	569	216	-7	-128	-163	666	573	283	52	-82	304	51	-113	-204	-232		
060	1278	1104	586	219	26	569	216	-7	-128	-163	666	573	283	52	-82	304	51	-113	-204	-232		
070	1278	1104	586	219	26	569	216	-7	-128	-163	666	573	283	52	-82	304	51	-113	-204	-232		
080	1778	1547	856	366	109	834	363	65	-96	-143	963	838	452	144	-34	480	143	-76	-198	-234		
090	1778	1547	856	366	109	834	363	65	-96	-143	963	838	452	144	-34	480	143	-76	-198	-234		
100	1608	1377	686	196	-61	664	193	-105	-266	-313	793	668	282	-26	-204	310	-27	-246	-368	-404		
110	1608	1377	686	196	-61	664	193	-105	-266	-313	793	668	282	-26	-204	310	-27	-246	-368	-404		
120	1608	1377	686	196	-61	664	193	-105	-266	-313	793	668	282	-26	-204	310	-27	-246	-368	-404		
130	1608	1377	686	196	-61	664	193	-105	-266	-313	793	668	282	-26	-204	310	-27	-246	-368	-404		



Installation - Electrical

General Recommendations

As you review this manual, keep in mind that:

- All field-installed wiring must conform to National Electric Code (NEC) guidelines, and any applicable state and local codes. Be sure to satisfy proper equipment grounding requirements per NEC.
- Compressor motor and unit electrical data is listed on the chiller nameplate.
- All field-installed wiring must be checked for proper terminations, and for possible shorts or grounds.

Note: Always refer to wiring diagrams shipped with chiller or unit submittal for specific electrical schematic and connection information.

⚠ WARNING

Hazardous Voltage — Pressurized Burning Fluid!

Failure to follow all electrical safety precautions could result in death or serious injury.

Compressors on 110 and 120 ton, extra efficiency units, have strong permanent magnet motors that have the capability to generate voltage during situations when the refrigerant charge is being migrated. This potential will be present at the motor terminals and at the load side of compressor contactors.

Before removing compressor terminal box cover for servicing, or servicing power side of control panel, **CLOSE COMPRESSOR DISCHARGE SERVICE VALVE** and disconnect all electric power including remote disconnects. Follow lockout/tagout procedures to ensure the power cannot be inadvertently energized.

The compressor contains hot, pressurized refrigerant. Motor terminals act as a seal against this refrigerant. Care should be taken when servicing **NOT** to damage or loosen motor terminals.

Do not operate compressor without terminal box cover in place.

⚠ WARNING

Hazardous Voltage!

Disconnect all electric power, including remote disconnects before servicing. Follow proper lockout/tagout procedures to ensure the power can not be inadvertently energized. Failure to disconnect power before servicing could result in death or serious injury.

⚠ WARNING

Proper Field Wiring and Grounding Required!

Failure to follow code could result in death or serious injury. All field wiring **MUST** be performed by qualified personnel. Improperly installed and grounded field wiring poses **FIRE** and **ELECTROCUTION** hazards. To avoid these hazards, you **MUST** follow requirements for field wiring installation and grounding as described in NEC and your local/state electrical codes.

NOTICE:

Use Copper Conductors Only!

Failure to use copper conductors could result in equipment damage as the equipment was not designed or qualified to accept other types of conductors.

NOTICE:

Equipment Damage!

Do not allow conduit to interfere with other components, structural members or equipment. Control voltage (115V) wiring in conduit must be separate from conduit carrying low voltage (<30V) wiring. To prevent control malfunctions, do not run low voltage wiring (<30V) in conduit with conductors carrying more than 30 volts.

Installer-Supplied Components

Customer wiring interface connections are shown in the electrical schematics and connection diagrams that are shipped with the unit. The installer must provide the following components if not ordered with the unit:

- Power supply wiring (in conduit) for all field-wired connections.
- All control (interconnecting) wiring (in conduit) for field supplied devices.
- Circuit breakers.

Power Supply Wiring

⚠ WARNING

Proper Field Wiring and Grounding Required!

Failure to follow code could result in death or serious injury. All field wiring **MUST** be performed by qualified personnel. Improperly installed and grounded field wiring poses **FIRE** and **ELECTROCUTION** hazards. To avoid these hazards, you **MUST** follow requirements for field wiring installation and grounding as described in **NEC** and your local/state electrical codes.

All power supply wiring must be sized and selected accordingly by the project engineer in accordance with NEC Table 310-16.

⚠ WARNING

Hazardous Voltage!

Failure to disconnect power before servicing could result in death or serious injury. **Disconnect all electric power, including remote disconnects before servicing. Follow proper lockout/tagout procedures to ensure the power can not be inadvertently energized.**

All wiring must comply with local codes and the National Electrical Code. The installing (or electrical) contractor must provide and install the system interconnecting wiring, as well as the power supply wiring. It must be properly sized and equipped with the appropriate fused disconnect switches.

The type and installation location(s) of the fused disconnects must comply with all applicable codes.

NOTICE:

Use Copper Conductors Only!

Failure to use copper conductors could result in equipment damage as the equipment was not designed or qualified to accept other types of conductors.

Knock-outs for wiring are located on the bottom right side of the control panel. The wiring is passed through these conduits and connected to the terminal blocks or HACR type breakers. See [Figure 58, p. 86](#).

To provide proper phasing of 3-phase input, make connections as shown in field wiring diagrams and as stated on the WARNING label in the starter panel. Proper equipment ground must be provided to each ground connection in the panel (one for each customer-supplied conductor per phase).

The high voltage field-provided connections are made through knockouts on the right side of the panel. The low voltage connections are made through the left side of the panel ([Figure 58](#)). Additional grounds may be required for each 115 volt power supply to the unit. Green lugs are provided for 115V customer wiring.

Control Power Supply

The unit is equipped with a control power transformer; it is not necessary to provide additional control power voltage to the unit. No other loads should be connected to the control power transformer.

All units are factory-connected for appropriate labeled voltages.

NOTICE:

Equipment Damage!

Failure to follow instructions could cause catastrophic damage to the evaporator or partial heat recovery heat exchanger.

Control panel main processor does not check for loss of power to the heat tape nor does it verify thermostat operation. A qualified technician must verify power to the heat tape and confirm operation of the heat tape thermostat.

Heater Power Supply

For units with freeze protection selected (model number digit 18 is "1"), the evaporator shell is insulated from ambient air and protected from freezing temperatures by a thermostatically-controlled immersion heaters. When the ambient temperature drops to approximately 37°F (2.8°C) the thermostat energizes the heaters. The heaters will provide protection from ambient temperatures down to -20°F (-29°C).

It is required to provide an independent power source (115V 60-Hz-20 amp, 50Hz-15 amp), with a fused-disconnect to the heaters. The heaters are factory-wired back to the unit control panel.

Note: *If evaporator is drained, the heaters must be turned off to avoid damage to the heaters or heating elements. Damaged heaters could cause risk of evaporator damage once it is back in operation. The heater should only be on when the evaporator has water (or other solution) in it.*

Table 58. Power entrance

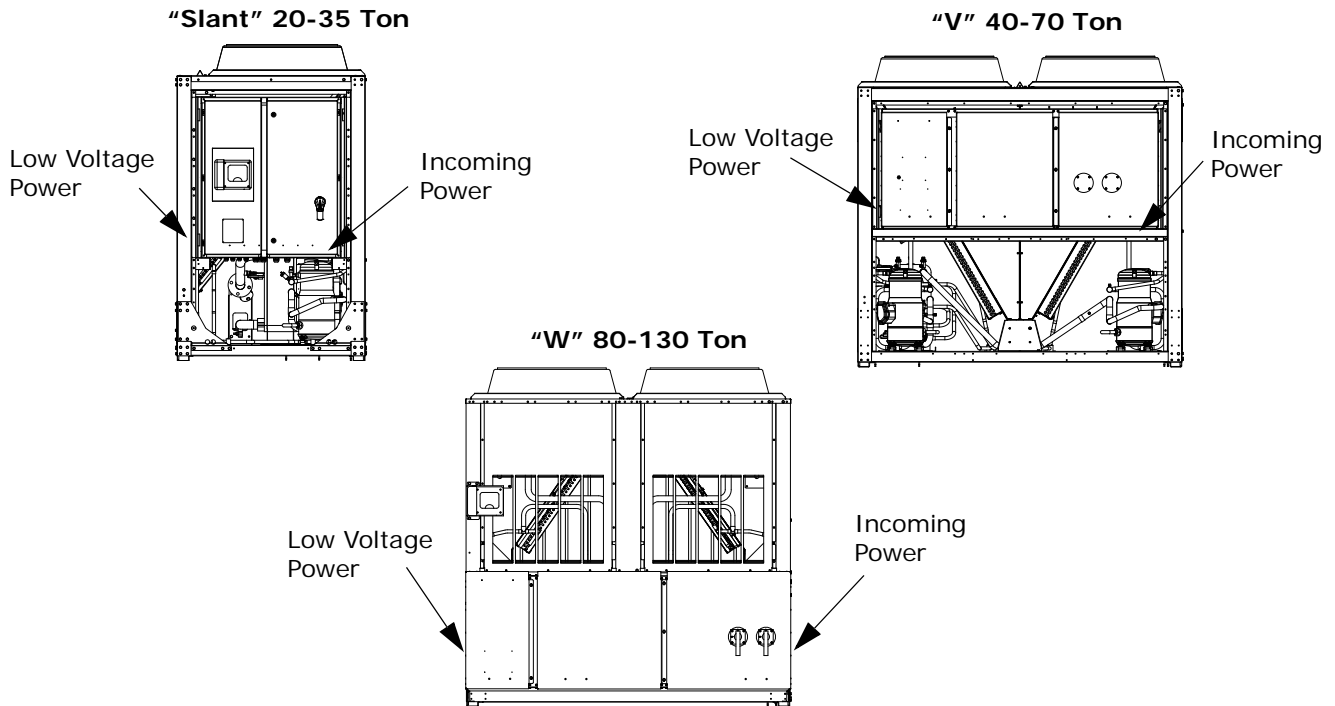

Partial Heat Recovery Power Supply

The partial heat recover heat exchanger is insulated from ambient air and protected from freezing temperatures by an immersion heater. When the ambient air temperature drops to approximately 37°F (2.8°C) the thermostat energizes the heaters. The heaters will provide protection from ambient temperatures down to -20°F (-29°C).

It is required to provide an independent power source (115V 60-Hz-20 amp, 50Hz-15 amp), with a fused-disconnect to the heater. The heaters are factory-wired back to the unit control panel.

Note: *If partial heat recovery heat exchanger is drained, the heater must be turned off in order to avoid damaging the partial heat recovery heat exchanger. The heater should only be on when the heat recovery heat exchanger has water in it.*

Water Pump Power Supply

Provide power supply wiring with disconnect for the chilled water pump(s).

Interconnecting Wiring

Chilled Water Flow (Pump) Interlock

All CGAM model chillers have a factory-installed flow switch. In addition, it is recommended to use an additional

field-supplied control voltage contact input through an auxiliary contact to prove flow. Connect the auxiliary contact to 1X5-3 and 1X5-9. Refer to the field wiring for details. The auxiliary contact can be a BAS signal, starter contactor auxiliary or any signal which indicates the pump is running.

Chilled Water Pump Control

An evaporator water pump output relay closes when the chiller is given a signal to go into the Auto mode of operation from any source. The contact is opened to turn off the pump in the event of most machine level diagnostics to prevent the build up of pump heat.

The relay output from 1A9 is required to operate the Evaporator Water Pump (EWP) contactor. Contacts should be compatible with 115/240 VAC control circuit. Normally, the EWP relay follows the AUTO mode of the chiller. Whenever the chiller has no diagnostics and is in the AUTO mode, regardless of where the auto command is coming from, the normally open relay is energized. When the chiller exits the AUTO mode, the relay is timed to open in an adjustable (using TechView™) 0 to 30 minutes. The non-AUTO modes in which the pump is stopped, include Reset, Stop, External Stop, Remote Display Stop, Stopped by Tracer®, Start Inhibited by Low Ambient Temp, and Ice Building complete.

NOTICE:

Equipment Damage!

If the microprocessor calls for a pump to start and water does not flow, the evaporator may be damaged catastrophically. It is the responsibility of the installing contractor and/or the customer to ensure that a pump will always be running when called upon by the chiller controls.

Table 59. Pump relay operation

Chiller Mode	Relay Operation
Auto	Instant close
Ice Building	Instant close
Tracer® Override	Close
Stop	Timed to Open
Ice Complete	Instant Open
Diagnostics	Instant Open

When going from Stop to Auto, the EWP relay is energized immediately. If evaporator water flow is not established in 4 minutes and 15 seconds, the CH530 de-energizes the EWP relay and generates a non-latching diagnostic. If flow returns (e.g. someone else is controlling the pump), the diagnostic is cleared, the EWP relay is re-energized, and normal control resumed.

If evaporator water flow is lost once it has been established, the EWP relay remains energized and a non-latching diagnostic is generated. If flow returns, the diagnostic is cleared and the chiller returns to normal operation.

NOTICE:

Equipment Damage!

Do NOT enable/disable the chiller by removing water flow or equipment damage can occur.

In general, when there is either a non-latching or latching diagnostic, the EWP relay is turned off as though there was a zero time delay. The relay continues to be energized with:

A Low Chilled Water Temperature diagnostic (non-latching) unless also accompanied by an Evap Leaving Water Temperature Sensor Diagnostic.

or

A Loss of Evaporator Water Flow diagnostic (non-latching) and the unit is in the AUTO mode, after initially having proven evaporator water flow.

Note: If pump control is used for freeze protection then the pump **MUST** be controlled by the CGAM CH530 control. If another method of freeze protection is used (i.e. glycol, heaters, purge, etc) then the pump may be controlled by another system.

Chilled Water Pump Control — Field Supplied Dual Pumps

If the unit is configured for dual pump, fixed-speed operations (two CH530-controlled pumps), CH530 provides two normally-open relay outputs (1A9), one for each pump, to command pump operation via a contactor. The control alternates pump operation for each new request for water flow. Restart during the pump off delay does not cause pump switch.

If evaporator water pump fault inputs are installed/used (1A12), CH530 provides two low-voltage binary fault inputs, one for each pump. A pump fault causes the respective pump relay to de-energize. A pump fault causes a “fault detected: evap pump X” diagnostic and an automatic, immediate switch to the idle pump if the idle pump does not already have an active pump fault diagnostic. If both pumps have an active pump fault diagnostic, unit operation will be prevented by a run inhibit. The run inhibit will be removed if either pump’s fault diagnostic clears. A “no evap water pumps available” submode is displayed when the run inhibit is active.

In this situation, the unit will leave the factory with Evaporator Pump Control (EVPC) = No Pump Control (Pump Request Relay) (NPMP) and Evaporator Pump Fault Input (EVFI) = Installed (INST). When the contactors and pumps are set up in the field, the CH530 Service Tool (TechView™) must be used to reconfigure to Evaporator Pump Control = Dual Pump Fixed Speed and Evaporator Pump Fault Input = Not Installed or Installed depending on how the fault feedback wire is connected. It is strongly recommended to install the Fault Input if possible as the controls will “hot-swap” the pumps upon detection of a fault, and may avoid the inevitable Flow Loss diagnostic (and unit shutdown) that will result if there is no fault feedback.

When configured for Dual Pump Fixed Speed, the CH530 will swap pumps on detection of a fault (if installed), or when a flow loss or overdue event occurs. It will also switch pumps each time the overall pump request is removed and re-engaged, unless a fault is detected on one of the pumps. If faults are detected on both pumps, the unit will be shut down.

In addition to the factory installed flow switch, a field-supplied auxiliary contact is required, so that the chiller will only detect flow if a pump is running and the flow switch says flow is present.

Chilled Water Pump Control — Optional Pump Package

When factory installed pump package option is selected, the chiller **MUST** control the pumps. See “Chilled Water Pump Control,” p. 86.

Alarm and Status Relay Outputs (Programmable Relays)

A programmable relay concept provides for enunciation of certain events or states of the chiller, selected from a list of likely needs, while only using four physical output relays, as shown in the field wiring diagram. The four relays are provided (generally with a Quad Relay Output LLID) as part of the Alarm Relay Output Option. The relay's contacts are

isolated Form C (SPDT), suitable for use with 120 VAC circuits drawing up to 2.8 amps inductive, 7.2 amps resistive, or 1/3 HP and for 240 VAC circuits drawing up to 0.5 amp resistive.

The list of events/states that can be assigned to the programmable relays can be found in [Table 60](#). The relay will be energized when the event/state occurs.

Table 60. Alarm and status relay output configuration

	Description
Alarm - Latching	This output is true whenever there is any active diagnostic that requires a manual reset to clear, that affects either the Chiller, the Circuit, or any of the Compressors on a circuit. This classification does not include informational diagnostics.
Alarm - Auto Reset	This output is true whenever there is any active diagnostic that could automatically clear, that affects either the Chiller, the Circuit, or any of the Compressors on a circuit. This classification does not include informational diagnostics.
Alarm	This output is true whenever there is any diagnostic affecting any component, whether latching or automatically clearing. This classification does not include informational diagnostics
Alarm Ckt 1	This output is true whenever there is any diagnostic effecting Refrigerant Circuit 1, whether latching or automatically clearing, including diagnostics affecting the entire chiller. This classification does not include informational diagnostics.
Alarm Ckt 2	This output is true whenever there is any diagnostic affecting Refrigerant Circuit 2 whether latching or automatically clearing, including diagnostics effecting the entire chiller. This classification does not include informational diagnostics.
Chiller Limit Mode (with a 20 minute filter)	This output is true whenever the chiller has been running in one of the Unloading types of limit modes (Condenser, Evaporator, Current Limit or Phase Imbalance Limit) continuously for the last 20 minutes.
Circuit 1 Running	This output is true whenever any compressor is running (or commanded to be running) on Refrigerant Circuit 1, and false when no compressors are commanded to be running on that circuit.
Circuit 2 Running	This output is true whenever any compressor is running (or commanded to be running) on Refrigerant Circuit 2, and false when no compressors are commanded to be running on that circuit.
Chiller Running	This output is true whenever any compressor is running (or commanded to be running) on the chiller and false when no compressors are commanded to be running on the chiller.
Maximum Capacity	This output is true whenever the chiller has all compressors on. The output is false once one compressor is shut off.

Relay Assignments Using TechView

CH530 Service Tool (TechView™) is used to install the Alarm and Status Relay Option package and assign any of the above list of events or status to each of the four relays provided with the option. The relays to be programmed are referred to by the relay's terminal numbers on the LLID board 1A18.

The default assignments for the four available relays of the CGAM Alarm and Status Package Option are:

Table 61. Default relay assignments

Relay	
Relay 1 Terminals J2 -12,11,10:	Compressor Running
Relay 2 Terminals J2 - 9,8,7:	Latching Alarm
Relay 3 Terminals J2-6,5,4:	Chiller Limit Mode
Relay 4 Terminals J2-3,2,1:	Warning

If any of the Alarm/Status relays are used, provide electrical power, 115 VAC with fused-disconnect to the panel and wire through the appropriate relays (terminals on 1A13. Provide wiring (switched hot, neutral, and ground connections) to the remote annunciation devices. Do not use power from the chiller's control panel transformer to power these remote devices. Refer to the field diagrams which are shipped with the unit.

Low Voltage Wiring

WARNING

Proper Field Wiring and Grounding Required!

Failure to follow code could result in death or serious injury. All field wiring MUST be performed by qualified personnel. Improperly installed and grounded field wiring poses FIRE and ELECTROCUTION hazards. To avoid these hazards, you MUST follow requirements for field wiring installation and grounding as described in NEC and your local/state electrical codes.

The remote devices described below require low voltage wiring. All wiring to and from these remote input devices to the Control Panel must be made with shielded, twisted pair conductors. Be sure to ground the shielding only at the panel.

Note: To prevent control malfunctions, do not run low voltage wiring (<30 V) in conduit with conductors carrying more than 30 volts.

Emergency Stop

CH530 provides auxiliary control for a customer specified/ installed latching trip out. When this customer-furnished

remote contact 6K5 is provided, the chiller will run normally when the contact is closed. When the contact opens, the unit will trip on a manually resettable diagnostic. This condition requires manual reset at the chiller switch on the front of the control panel.

Connect low voltage leads to terminal strip locations on 1A13, J2-3 and 4. Refer to the field diagrams that are shipped with the unit.

Silver or gold-plated contacts are recommended. These customer-furnished contacts must be compatible with 24 VDC, 12 mA resistive load.

External Auto/Stop

If the unit requires the external Auto/Stop function, the installer must provide leads from the remote contact 6K4 to the proper terminals on 1A13, J2-1 and 2.

The chiller will run normally when the contact is closed. When the contact opens, the compressor(s), if operating, will go to the RUN:UNLOAD operating mode and cycle off. Unit operation will be inhibited. Closure of the contact will permit the unit to return to normal operation.

Field-supplied contacts for all low voltage connections must be compatible with dry circuit 24 VDC for a 12 mA resistive load. See the field diagrams that are shipped with the unit.

NOTICE:

Equipment Damage!

Do NOT enable/disable the chiller by removing water flow or equipment damage can occur.

Ice Building Option

CH530 provides auxiliary control for a customer specified/ installed contact closure for ice building if so configured and enabled. This output is known as the Ice Building Status Relay. The normally open contact will be closed when ice building is in progress and open when ice building has been normally terminated either through Ice Termination setpoint being reached or removal of the Ice Building command. When contact 6K6 is provided, the chiller will run normally when the contact is open.

CH530 will accept either an isolated contact closure (External Ice Building command) or a Remote Communicated input (Tracer®) to initiate and command the Ice Building mode.

CH530 also provides a "Front Panel Ice Termination Setpoint," settable through TechView™, and adjustable from 20 to 31°F (-6.7 to -0.5°C) in at least 1°F (1°C) increments.

When in the Ice Building mode, and the evaporator entering water temperature drops below the ice termination setpoint, the chiller terminates the Ice Building mode and changes to the Ice Building Complete Mode.

NOTICE:

Evaporator Damage!

Freeze inhibitor must be adequate for the leaving water temperature. Failure to do so could result in damage to system components.

TechView™ may also be used to enable or disable Ice Machine Control. This setting does not prevent the Tracer® from commanding Ice Building mode.

Upon contact closure, the CH530 will initiate an ice building mode, in which the unit runs fully loaded at all times. Ice building shall be terminated either by opening the contact or based on the entering evaporator water temperature. CH530 will not permit the ice building mode to be reentered until the unit has been switched out of ice building mode (open 5K20 contacts) and then switched back into ice building mode (close 5K20 contacts.)

In ice building, all limits (freeze avoidance, evaporator, condenser, current) will be ignored. All safeties will be enforced.

If, while in ice building mode, the unit gets down to the freeze stat setting (water or refrigerant), the unit will shut down on a manually resettable diagnostic, just as in normal operation.

Connect leads from 6K6 to the proper terminals of 1A16. Refer to the field diagrams which are shipped with the unit.

Silver or gold-plated contacts are recommended. These customer furnished contacts must be compatible with 24 VDC, 12 mA resistive load.

External Chilled Water Setpoint (ECWS) Option

The CH530 provides inputs that accept either 4-20 mA or 2-10 VDC signals to set the external chilled water setpoint (ECWS). **This is not a reset function.** The input defines the set point. This input is primarily used with generic BAS (building automation systems). The chilled water setpoint set via the DynaView™ or through digital communication with Tracer®.

The chilled water setpoint may be changed from a remote location by sending either a 2-10 VDC or 4-20 mA signal to the 1A14, J2-1 and 2. The 2-10 VDC and 4-20 mA each correspond to a 10 to 65°F (-12 to 18°C) external chilled water setpoint.

The following equations apply:

Voltage Signal

$$\text{VDC} = \frac{(8 * \text{ECWS}^{\circ}\text{F} + 2 * \text{ECWS}_{\text{max}} - 10 * \text{ECWS}_{\text{min}})}{(\text{ECWS}_{\text{max}} - \text{ECWS}_{\text{min}})}$$

Current Signal

$$\text{mA} = \frac{(16 * \text{ECWS}^{\circ}\text{F} + 4 * \text{ECWS}_{\text{max}} - 20 * \text{ECWS}_{\text{min}})}{(\text{ECWS}_{\text{max}} - \text{ECWS}_{\text{min}})}$$

Note: To convert ECWS values to °F, use the following formula: °F = 1.8*(°C) + 32

If the ECWS input develops an open or short, the LLID will report either a very high or very low value back to the main processor. This will generate an informational diagnostic and the unit will default to using the Front Panel (DynaView™) Chilled Water Setpoint.

TechView™ Service Tool is used to set the input signal type from the factory default of 2-10 VDC to that of 4-20 mA. TechView™ is also used to install or remove the External Chilled Water Setpoint option as well as a means to enable and disable ECWS.

External Demand Limit Setpoint (EDLS) Option

CH530 provide a means to limit the capacity of the chiller by limiting the number of compressors or stages that are allowed to run. The maximum number of compressor or stages allowed to run can vary from one to the number of stages on the unit. The staging algorithm is free to decide which compressor or stage shall be turned off or prevented from running to meet this requirement.

CH530 shall accept either a 2-10 VDC or 4-20 mA analog input suitable for customer connection to set the unit external demand limit setpoint (EDLS).

2-10 VDC and 4-20 mA shall each correspond to an EDLS range with a minimum of 0% and a maximum of 100%. The following equations exist.

	Voltage Signal	Current Signal
As generated from external source	$V_{dc} = 8 * (EDLS) + 2$	$mA = 16 * (EDLS) + 4$
As processed by CH530	$EDLS = (V_{dc} - 2) / 8$	$EDLS = (mA - 4) / 16$

The minimum EDLS will be clamped at the front panel based on 100% / Total number of Compressors. For input signals beyond the 2-10VDC or 4-20mA range, the end of range value shall be used. For example, if the customer inputs 21 mA, the EDLS shall limit it self to the corresponding 20 mA EDLS.

ECWS and EDLS Analog Input Signal Wiring Details

Both the ESWS and EDLS can be connected and setup as either a 2-10 VDC (factory default), 4-20 mA, or resistance input (also a form of 4-20 mA) as indicated below. Depending on the type to be used, the TechView™ Service Tool must be used to configure the LLID and the MP for the proper input type that is being used. This is accomplished by a setting change on the Custom Tab of the Configuration View within TechView™.

The J2-3 and J2-6 terminal is chassis grounded and terminal J2-1 and J2-4 can be used to source 12 VDC. The ECLS uses terminals J2-2 and J2-3. EDLS uses terminals J2-5 and J2-6. Both inputs are only compatible with high-side current sources.

Figure 52. Wiring examples for ECLS and EDLS

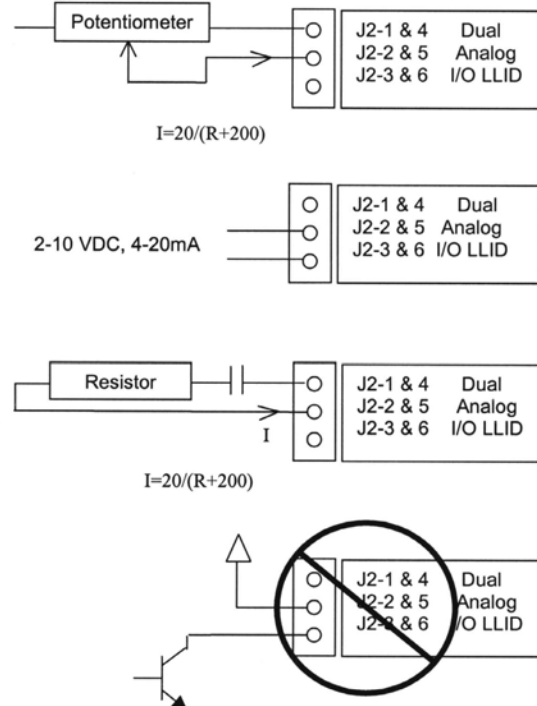

Chilled Water Reset (CWR)

CH530 resets the chilled water temperature set point based on either return water temperature, or outdoor air temperature.

The following shall be selectable:

- One of three Reset Types: None, Return Water Temperature Reset, Outdoor Air Temperature Reset, or Constant Return Water Temperature Reset.
- Reset Ratio Set Points.
- For outdoor air temperature reset there shall be both positive and negative reset ratio's.
- Start Reset Set Points.
- Maximum Reset Set Points.

The equations for each type of reset are as follows:

Return

$$CWS' = CWS + \text{RATIO} (\text{START RESET} - (TWE - TWL))$$

$$\text{and } CWS' > \text{ or } = CWS$$

$$\text{and } CWS' - CWS < \text{ or } = \text{Maximum Reset}$$

Outdoor

$$CWS' = CWS + \text{RATIO} * (\text{START RESET} - \text{TOD})$$

$$\text{and } CWS' > \text{ or } = CWS$$

$$\text{and } CWS' - CWS < \text{ or } = \text{Maximum Reset}$$

where

CWS' is the new chilled water set point or the "reset CWS"

CWS is the active chilled water set point before any reset has occurred, e.g. normally Front Panel, Tracer®, or ECWS

RESET RATIO is a user adjustable gain

START RESET is a user adjustable reference

TOD is the outdoor temperature

TWE is entering evap. water temperature

TWL is leaving evap. water temperature

MAXIMUM RESET is a user adjustable limit providing the maximum amount of reset. For all types of reset, $CWS' - CWS < \text{or} = \text{Maximum Reset}$.

Reset Type	Reset Ratio Range	Start Reset Range	Maximum Reset Range	Increment IP	SI	Factory Default Value
Return	10-120%	4-30°F (2.2-16.7°C)	0-20°F (0.0-11.1°C)	1%	1%	50%
Outdoor	80-80%	50 - 130°F (10-54.4°C)	0 - 20°F (0.0-11.1°C)	1%	1%	10%

In addition to Return and Outdoor Reset, the MP provides a menu item for the operator to select a Constant Return Reset. Constant Return Reset will reset the leaving water temperature set point so as to provide a constant entering water temperature. The Constant Return Reset equation is the same as the Return Reset equation except on selection of Constant Return Reset, the MP will automatically set Ratio, Start Reset, and Maximum Reset to the following.

RATIO = 100%

START RESET = Design Delta Temp.

MAXIMUM RESET = Design Delta Temp.

The equation for Constant Return is then as follows:

$CWS' = CWS + 100\% (\text{Design Delta Temp.} - (TWE - TWL))$
and $CWS' > \text{or} = CWS$

and $CWS' - CWS < \text{or} = \text{Maximum Reset}$

When any type of CWR is enabled, the MP will step the Active CWS toward the desired CWS' (based on the above equations and setup parameters) at a rate of 1 degree F every 5 minutes until the Active CWS equals the desired CWS'. This applies when the chiller is running.

When the chiller is not running the CWS is reset immediately (within one minute) for Return Reset and at a rate of 1 degree F every 5 minutes for Outdoor Reset. The chiller will start at the Differential to Start value above a fully reset CWS or CWS' for both Return and Outdoor Reset.

Percent Capacity Output Option

CH530 provides an optional percent capacity output for those customers without a communicating BAS interface. The active unit capacity (AUC) is provided through a 2-10 VDC analog output at 1A25 terminals J2-4 and J2-6 (GND). The active unit capacity value (in %) can be derived from the 2-10 VDC output voltage (OV) using the following calculation:

$$AUC = 100 * (OV - 2.0V) / (10.0V - 2.0V)$$

Note: The percent capacity output is based on the number and size of compressors energized, and is not adjusted for operating conditions. This value cannot be used as an accurate measure of total unit current, power or cooling capacity.

Communications Interface Options

Tracer Communications Interface

This option allows the Tracer® CH530 controller to exchange information (e.g. operating setpoints and Auto/Standby commands) with a higher-level control device, such as a Tracer® Summit or a multiple-machine controller. A shielded, twisted pair connection establishes the bi-directional communications link between the Tracer® CH530 and the building automation system.

Note: To prevent control malfunctions, do not run low voltage wiring (<30 V) in conduit with conductors carrying more than 30 volts.

⚠ WARNING

Proper Field Wiring and Grounding Required!

Failure to follow code could result in death or serious injury. All field wiring MUST be performed by qualified personnel. Improperly installed and grounded field wiring poses FIRE and ELECTROCUTION hazards. To avoid these hazards, you MUST follow requirements for field wiring installation and grounding as described in NEC and your local/state electrical codes.

Field wiring for the communication link must meet the following requirements:

- All wiring must be in accordance with the NEC and local codes.
- Communication link wiring must be shielded, twisted pair wiring (Belden 8760 or equivalent). See the table below for wire size selection:



Table 62. Wire size

Wire Size	Maximum Length of Communication Wire
14 AWG (2.5 mm ²)	5,000 FT (1525 m)
16 AWG (1.5 mm ²)	2,000 FT (610 m)
18 AWG (1.0 mm ²)	1,000 FT (305 m)

- The communication link cannot pass between buildings.
- All units on the communication link can be connected in a “daisy chain” configuration.

LonTalk Communications Interface for Chillers (LCI-C)

CH530 provides an optional LonTalk[®] Communication Interface (LCI-C) between the chiller and a Building Automation System (BAS). An LCI-C LLID shall be used to provide “gateway” functionality between a LonTalk[®] compatible device and the Chiller. The inputs/outputs include both mandatory and optional network variables as established by the LONMARK[®] Functional Chiller Profile 8040.

Note: For more information, see ACC-SVN25*-EN.

BACnet Interface (BCI-C)

Optional BACnet[®] Communication Interface for Chillers (BCI-C) is comprised of a Tracer[®] UC400 controller with interface software. It is a non-programmable communications module that allows units to communicate on a BACnet[®] communications network.

Note: For more information, see BAS-SVP05*-EN.



CGAM Operating Principles

This section contains an overview of the operation of CGAM air-cooled liquid chiller equipped with microcomputer-based control systems. It describes the overall operating principles of the CGAM water chiller.

Note: *To ensure proper diagnosis and repair, contact a qualified service organization if a problem should occur.*

General

The Model CGAM units are scroll compressor air-cooled liquid chillers. These units are equipped with unit-mounted starter/control panels and operates with R-410A refrigerant.

The basic components of an CGAM unit are:

- Unit-mounted panel containing starter and Tracer CH530 controller and Input/Output LLIDS
- Scroll compressors
- Brazed plate evaporator
- Air-cooled condenser with subcooler
- Electronic expansion valve
- Optional partial heat recovery
- Related interconnecting piping.

Components of a typical CGAM unit are identified in the following diagrams.

Base Units

Figure 53. Slant 20 to 35 ton component location

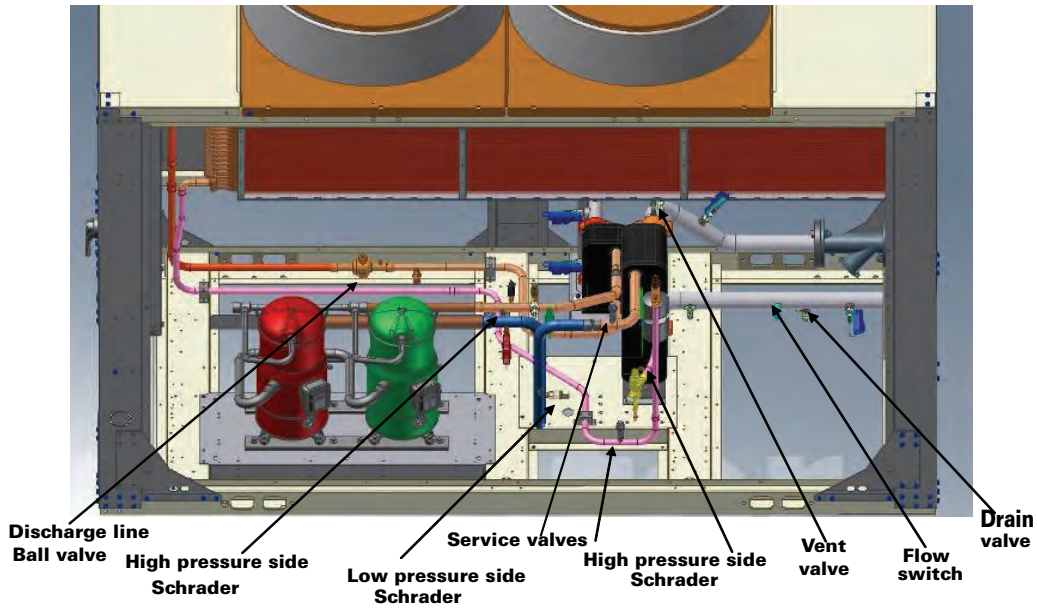

Figure 54. V 40 to 70 ton component location, circuit 1

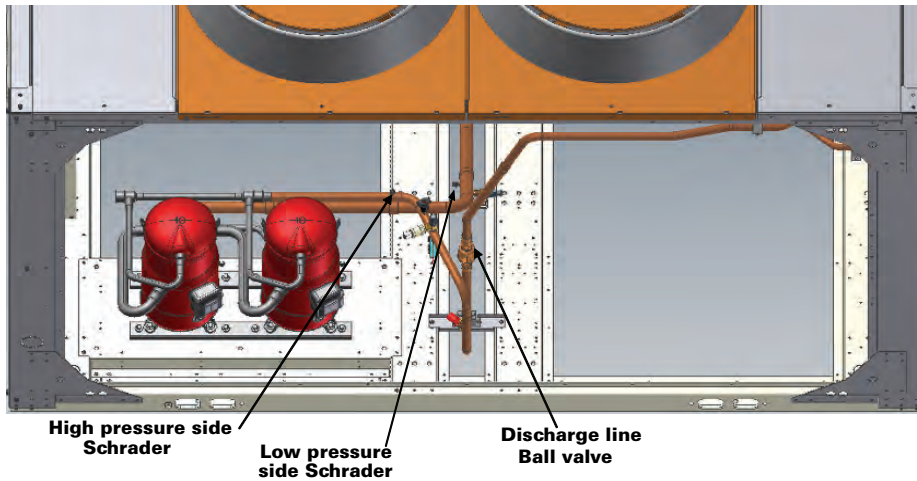

Figure 55. V 40 to 70 ton component location, circuit 2

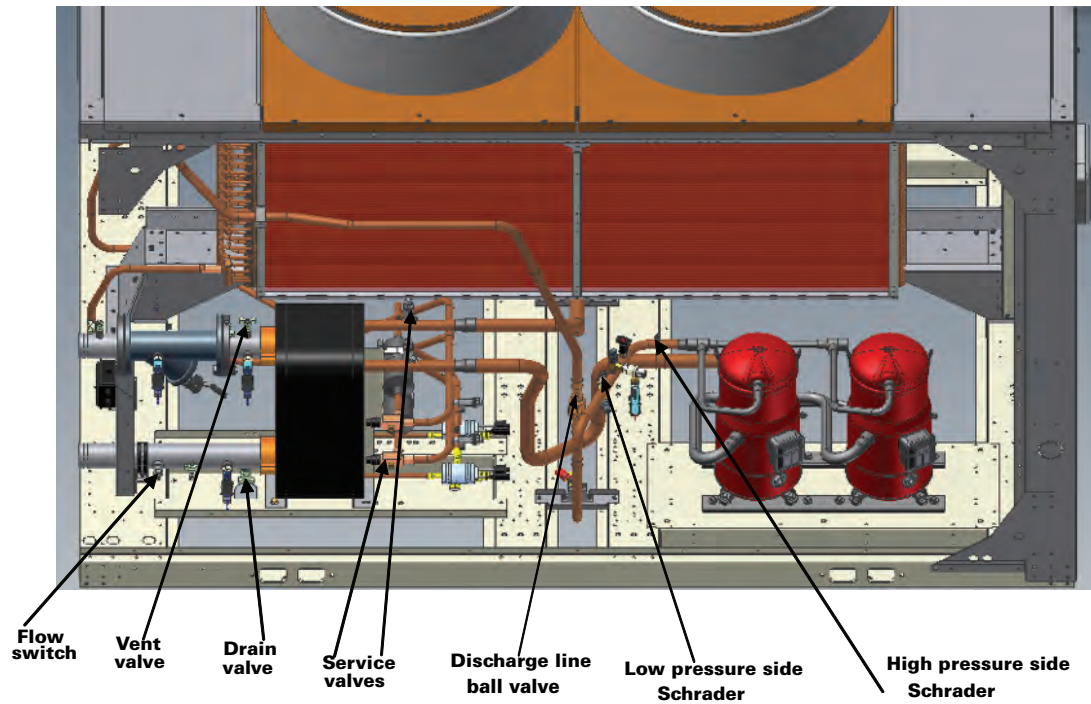

Figure 56. W 80 to 130 ton component location, compressor view

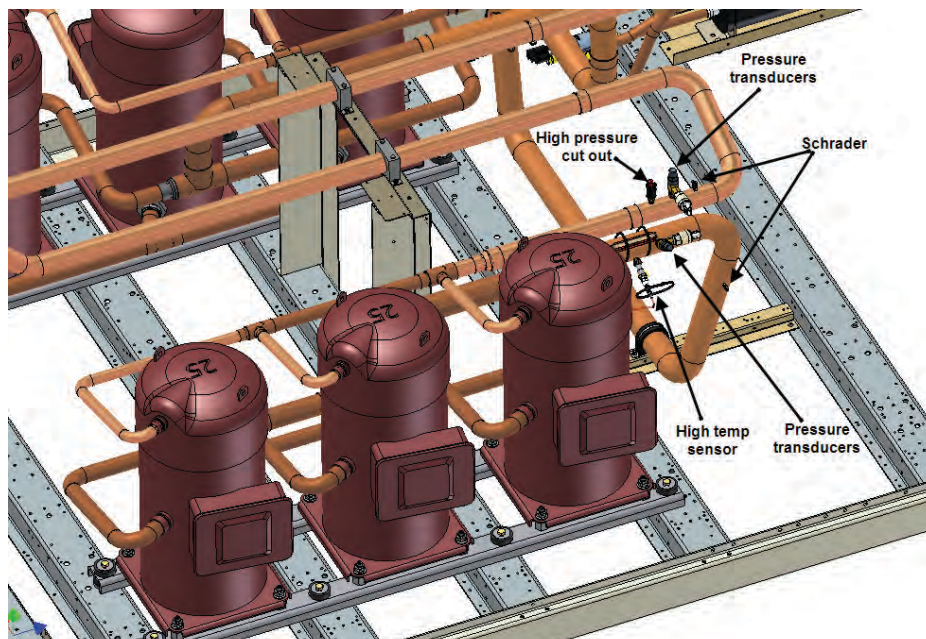
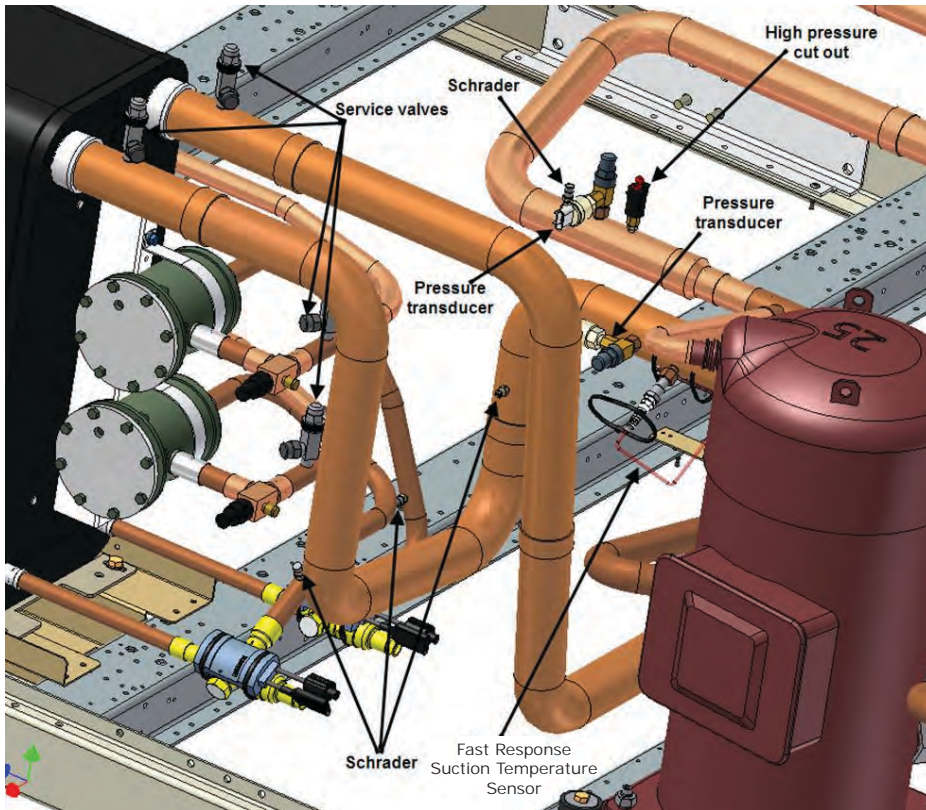

Figure 57. W 80 to 130 ton component location, evaporator side



Pump Package Components - Optional

Figure 58. Pump package components, slant 20 to 35 ton, view 1

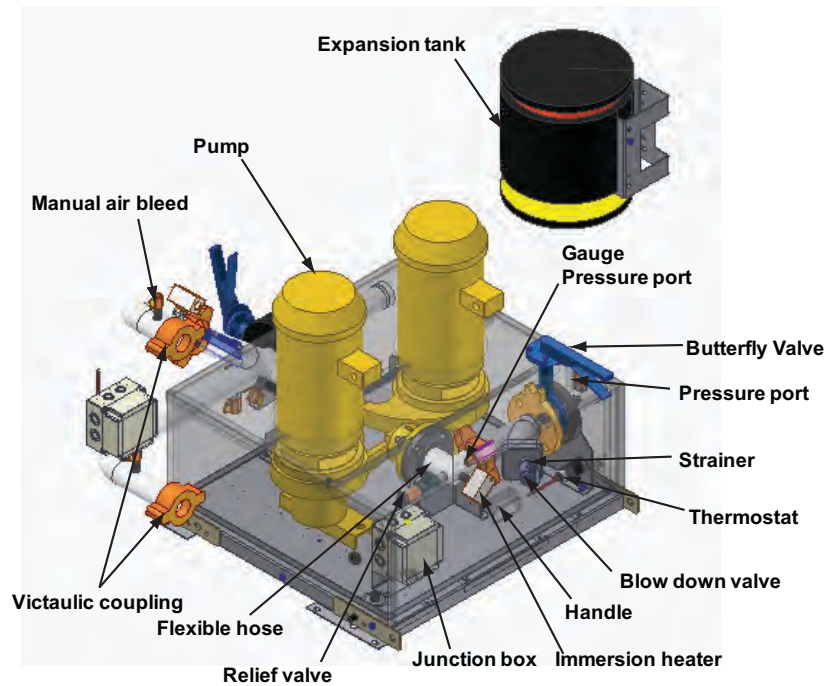

Figure 59. Pump package components, slant 20 to 35 ton, view 2

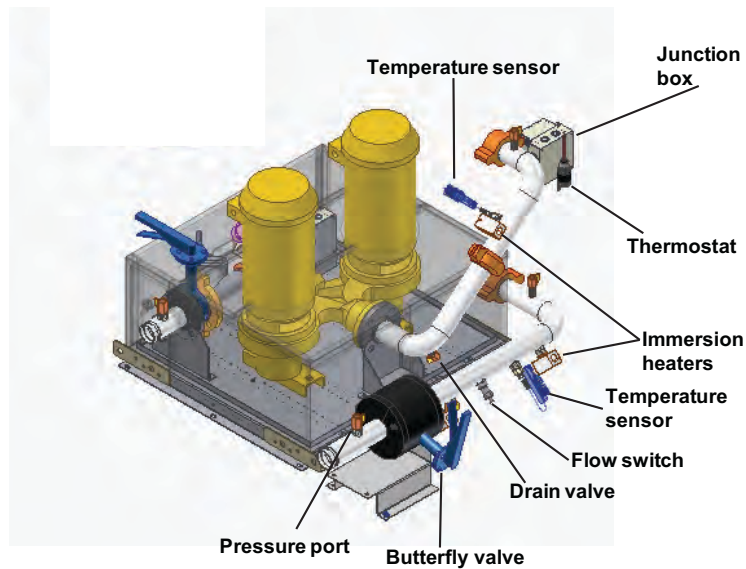

Figure 60. Pump package components, V 40 to 70T, view 1

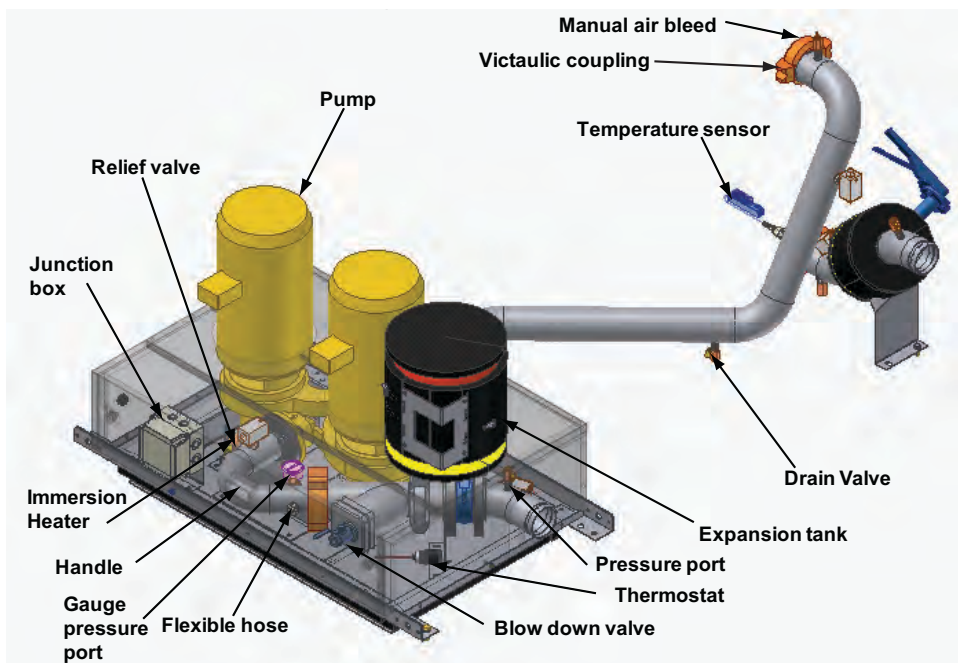

Figure 61. Pump package components, V 40 to 70T, view 2

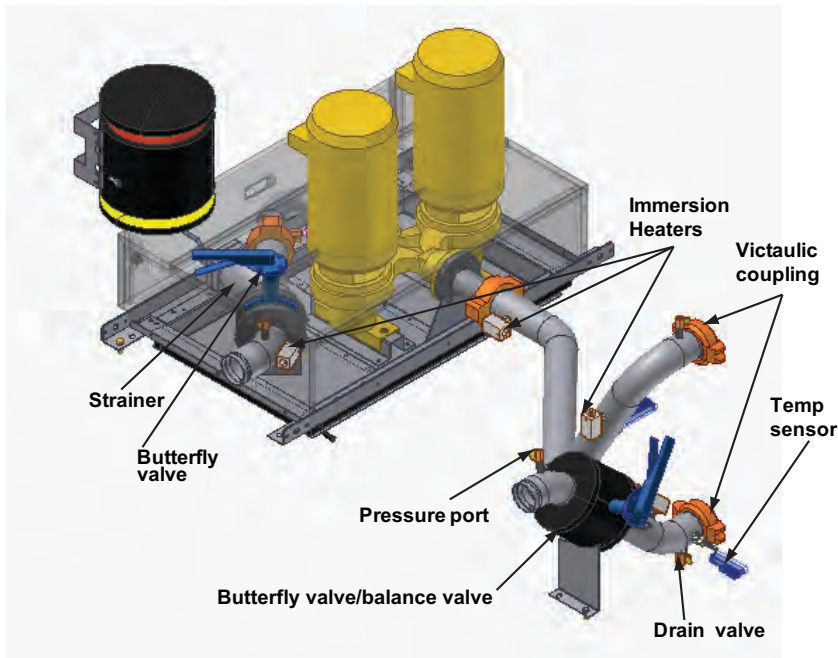

Figure 62. Pump package components, V 40 to 70 ton, view 3

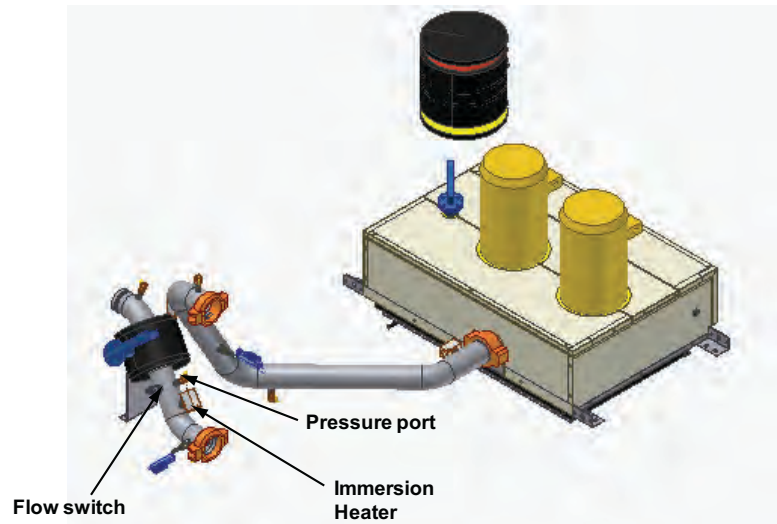

Figure 63. Pump package components, W 80 to 130 ton, view 1

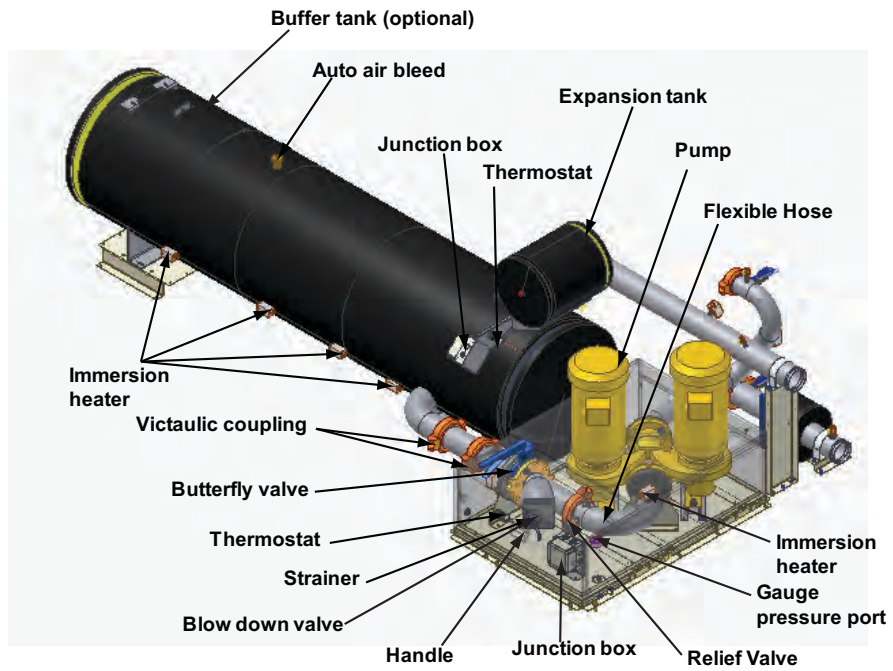
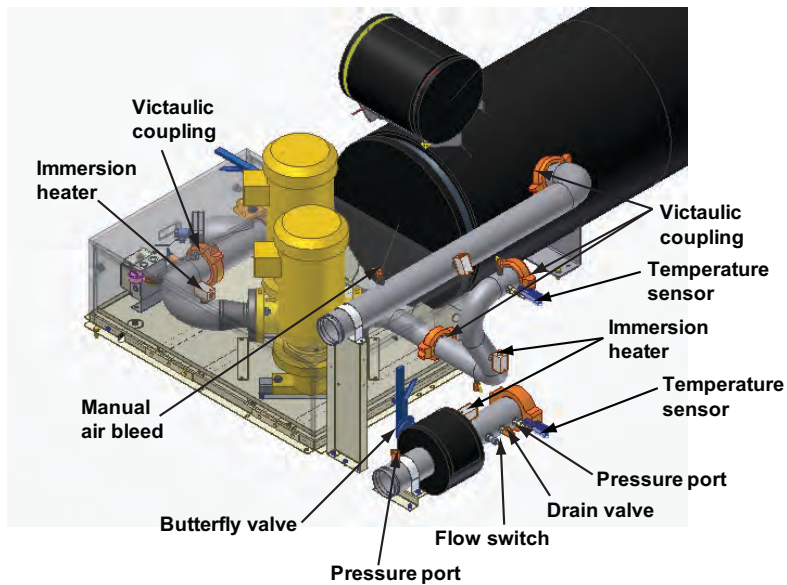
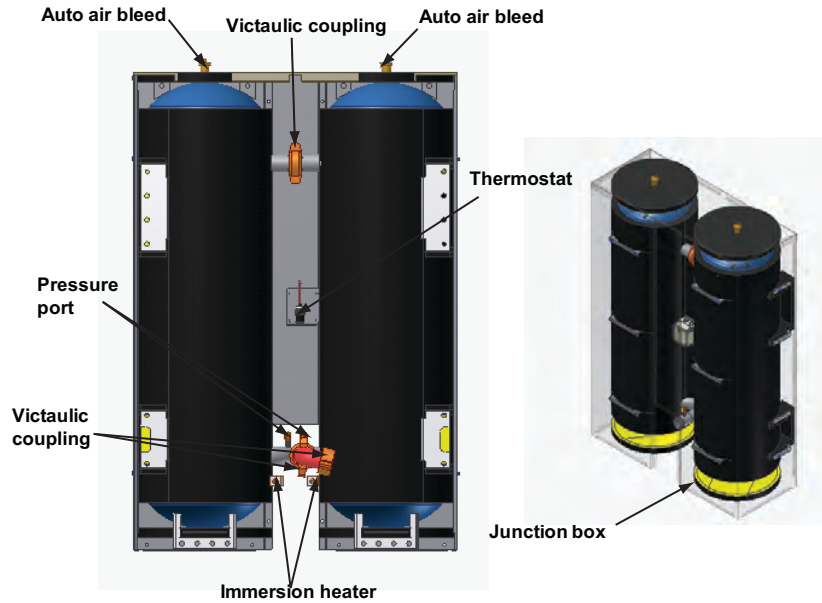

Figure 64. Pump package components, W 80 to 130 ton, view 2



Buffer Tank Components - Optional

Figure 65. Buffer tank components, slant 20 to 35 ton and V 40 to 70 ton



Partial Heat Recovery Components

Figure 66. Partial heat recovery components, slant 20 to 35 ton

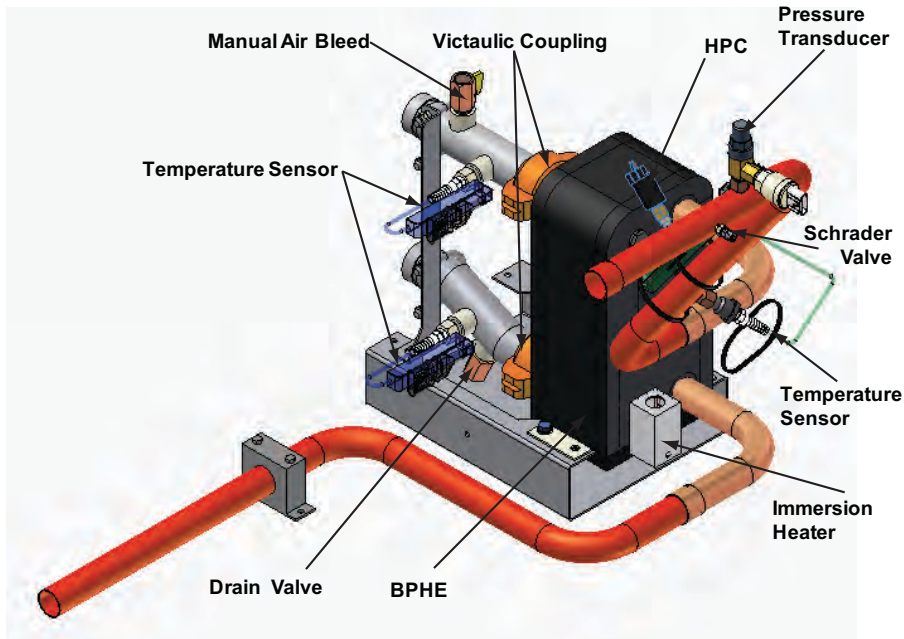

Figure 67. Partial heat recovery components, V 40 to 70 ton

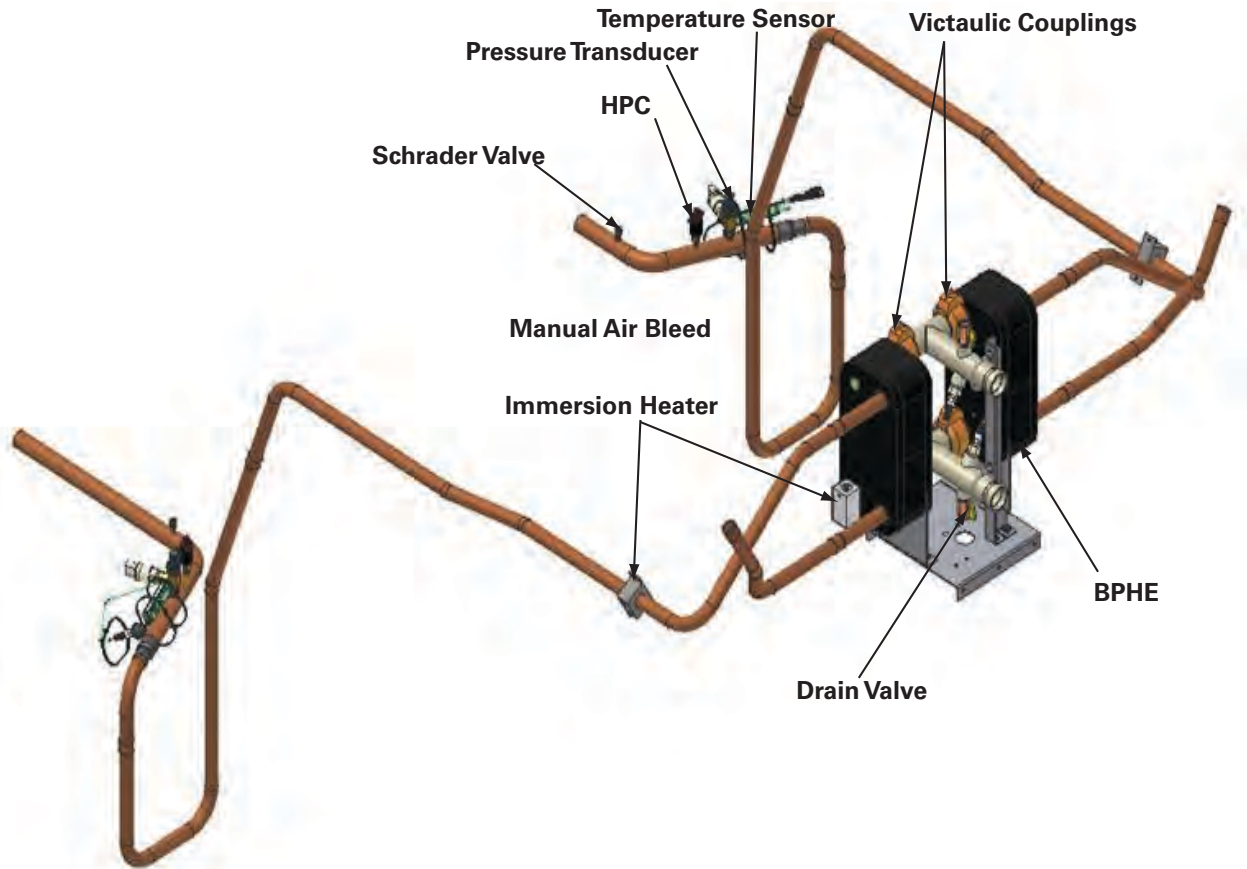
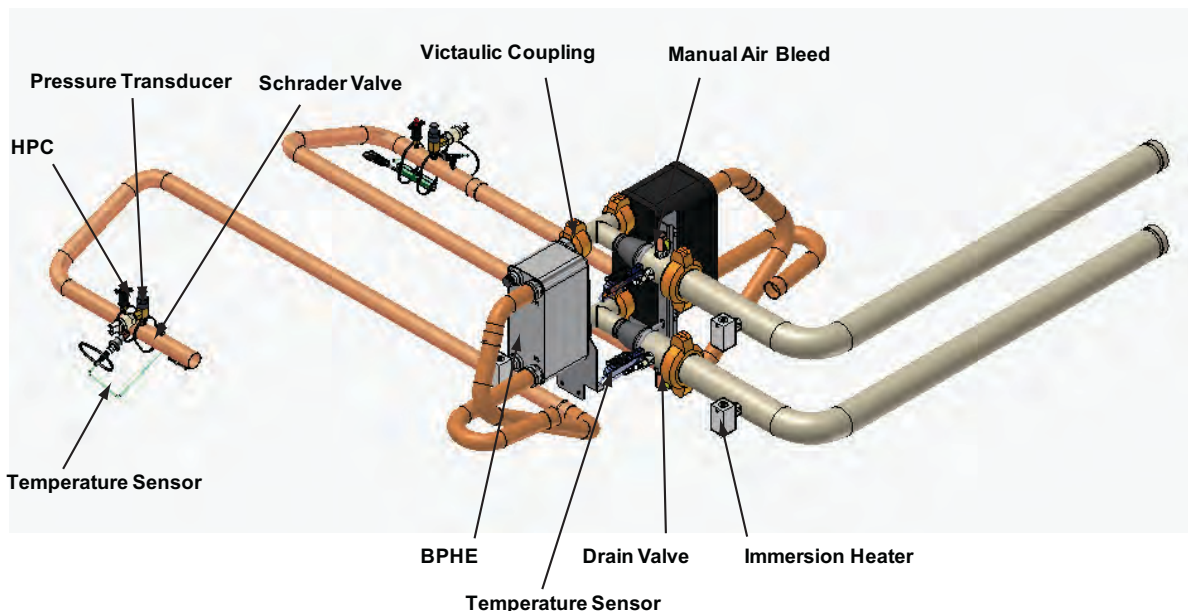

Figure 68. Partial heat recovery components — W 80 to 130 ton



Refrigerant Cycle

The refrigeration cycle of the Model CGAM chiller is conceptually similar to other Trane air-cooled chiller products. The CGAM chiller uses a brazed plate evaporator and an air-cooled condenser. The compressors use suction gas cooled motors and an oil management system to provide almost oil-free refrigerant to the condenser and evaporator for maximum heat transfer while lubricating and sealing compressor bearings. The lubrication system helps to assure long compressor life and contributes to quiet operation.

Refrigerant condensers in the air-cooled heat exchanger which is available in three configurations—slant, V and W—based on the CGAM nominal tonnage cooling capacity. Liquid refrigerant is metered into the brazed plate evaporator using an electronic expansion valve to maximize chiller efficiency at full and part load operation.

The CGAM chiller is equipped with a unit-mounted starter and control panel. Microprocessor-based unit control modules (Trane Tracer[®] CH530) provide accurate chilled water control and provide monitoring, protection and adaptive limit functions. The adaptive nature of the controls intelligently prevent the chiller from operating outside of its limits, or compensates for unusual operating conditions while keeping the chiller running rather than simply shutting off the chiller. If problems do occur, the CH530 controls provide diagnostic messages to help the operator in troubleshooting.

Refrigerant Cycle Description

The CGAM refrigeration cycle is described using the pressure-enthalpy chart shown in [Figure 69](#). Key State Points 1 through 5 are indicated on the chart. A schematic showing refrigerant components throughout the system is shown in [Figure 69](#).

Refrigerant evaporation occurs in the brazed plate evaporator. Metered refrigerant vaporizes as it cools the chilled water or liquid flowing through the evaporator passages. The refrigerant vapor leaves the evaporator as superheated gas. State Point 1.

Refrigerant vapor generated in the evaporator flows to the compressor suction manifold where it enters and flows across the compressor motor windings to provide cooling. The vapor is then compressed in the compressor scroll chambers and discharged. Oil from the compressor sump lubricates the bearings and seals the small clearances between the compressor scrolls. Refrigerant vapor is discharged to the air-cooled condenser at State Point 2.

After the refrigerant vapor condenses into liquid (State Points 3 and 4) it is returned to the evaporator (State Point 5) where the refrigerant again flashes into vapor and the refrigeration cycle repeats.

Figure 69. Pressure/enthalpy curve

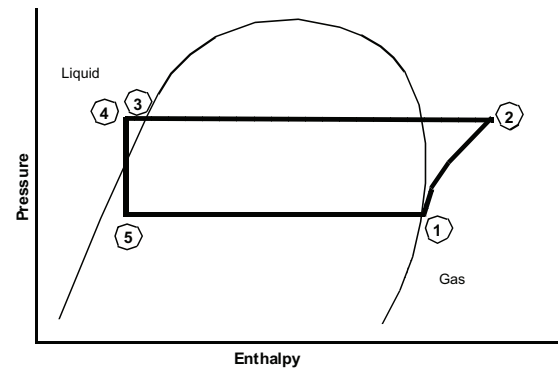

Oil System Operation (CGAM)

The oil is efficiently separated inside the scroll compressor and will remain in the scroll compressor during all run cycles. Between 1-2% of the oil circulates around with the refrigerant.

Sensor Requirements

Discharge temperature sensor is required for units with the following options:

- Low Temperature Process (model number digit 21 = B)
- Ice-Making (model number digit 21 = C)
- Low Leaving Water (model number digit 21 = D)
- Partial Heat Recovery with Fan Control (model number digit 24 = 1)
- Heat Pump (applicable only to units built in Epinal)



Controls Interface

CH530 Communications Overview

The Trane CH530 control system that runs the chiller consists of several elements:

- The main processor collects data, status, and diagnostic information and communicates commands to the starter module and the LLID (for Low Level Intelligent Device) bus. The main processor has an integral display (DynaView™).
- Low level intelligent device (LLID) bus. The main processor communicates to each input and output device (e.g. temperature and pressure sensors, low voltage binary inputs, analog input/output) all connected to a four-wire bus, rather than the conventional control architecture of signal wires for each device.
- The communication interface to a building automation system (BAS).
- A service tool to provide all service/maintenance capabilities.

Main processor and service tool (TechView™) software is downloadable from www.trane.com. The process is discussed later in this section under TechView Interface.

DynaView™ provides bus management. It has the task of restarting the link, or filling in for what it sees as “missing” devices when normal communications has been degraded. Use of TechView may be required.

The CH530 uses the IPC3 protocol based on RS485 signal technology and communicating at 19.2 Kbaud to allow 3 rounds of data per second on a 64-device network. A typical four-compressor CGAM will have around 30 devices.

Most diagnostics are handled by the DynaView™. If a temperature or pressure is reported out of range by a LLID, the DynaView™ processes this information and calls out the diagnostic. The individual LLIDs are not responsible for any diagnostic functions.

Note: *It is imperative that the CH530 Service Tool (TechView) be used to facilitate the replacement of any LLID or reconfigure any chiller component. TechView is discussed later in this section.*

Controls Interface

Each chiller is equipped with a DynaView™ interface. The DynaView™ has the capability to display information to the operator including the ability to adjust settings. Multiple screens are available and text is presented in multiple languages as factory-ordered or can be easily downloaded from www.trane.com.

TechView can be connected to the DynaView™ module and provides further data, adjustment capabilities, diagnostics information using downloadable software.

DynaView Interface

The DynaView™ enclosure design is weatherproof and made of durable plastic for use as a device on the outside of the unit.

The display on DynaView™ is a 1/4 VGA display with a resistive touch screen and an LED backlight. The display area is approximately 4 inches wide by 3 inches high (102mm x 60mm).

Key Functions

In this touch screen application, key functions are determined completely by software and change depending upon the subject matter currently being displayed. The basic touch screen functions are outlined below.

Radio Buttons

Radio buttons show one menu choice among two or more alternatives, all visible. The radio button model mimics the buttons used on old-fashioned radios to select stations. When one is pressed, the one that was previously pressed “pops out” and the new station is selected. In the DynaView™ model the possible selections are each associated with a button. The selected button is darkened, presented in reverse video to indicate it is the selected choice. The full range of possible choices as well as the current choice is always in view.

Spin Value Buttons

Spin values are used to allow a variable setpoint to be changed, such as leaving water setpoint. The value increases or decreases by touching the increment (+) or decrement (-) arrows.

Action Buttons

Action buttons appear temporarily and provide the user with a choice such as **Enter** or **Cancel**.

Hot Links

Hot links are used to navigate from one view to another view.

File Folder Tabs

File folder tabs are used to select a screen of data. Just like tabs in a file folder, these serve to title the folder/screen selected, as well as provide navigation to other screens. In DynaView™, the tabs are in one row across the top of the display. The folder tabs are separated from the rest of the display by a horizontal line. Vertical lines separate the tabs from each other. The folder that is selected has no horizontal line under its tab, thereby making it look like a part of the current folder (as would an open folder in a file cabinet). The user selects a screen of information by touching the appropriate tab.

Display Screens

Basic Screen Format

The basic screen format appears as:

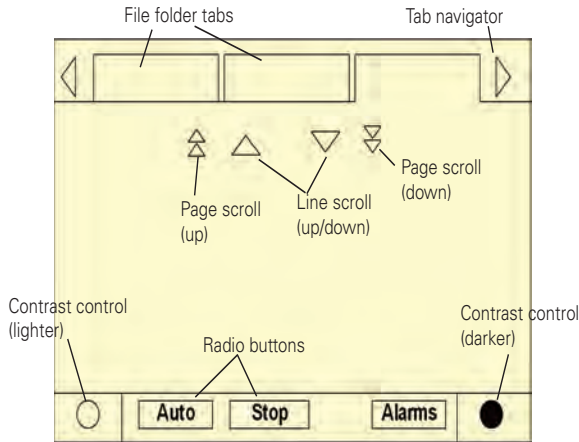

The file folder tabs across the top of the screen are used to select the various display screens.

Scroll arrows are added if more file tabs (choices) are available. When the tabs are at the left most position, the left navigator will not show and only navigation to the right will be possible. Likewise when the right most screen is selected, only left navigation will be possible.

The main body of the screen is used for description text, data, setpoints, or keys (touch sensitive areas). The Chiller Mode is displayed here.

The double up arrows cause a page-by-page scroll either up or down. The single arrow causes a line by line scroll to occur. At the end of the page, the appropriate scroll bar will disappear.

A double arrow pointing to the right indicates more information is available about the specific item on that same line. Pressing it will bring you to a subscreen that will present the information or allow changes to settings.

The bottom of the screen (Fixed Display) is present in all screens and contains the following functions. The **left circular area** is used to reduce the contrast/viewing angle of the display. **The right circular area** is used to increase the contrast/viewing angle of the display. The contrast may require re-adjustment at ambient temperatures significantly different from those present at last adjustment.

The other functions are critical to machine operation. The AUTO and STOP keys are used to enable or disable the chiller. The key selected is in black (reverse video). The chiller will stop when the STOP key is touched and after completing the Shutting Down mode.

Touching the AUTO key will enable the chiller for active cooling if no diagnostic is present. (A separate action must be taken to clear active diagnostics.)

The AUTO and STOP keys, take precedence over the Enter and Cancel keys. (While a setting is being changed, AUTO and STOP keys are recognized even if Enter or Cancel has not been pressed.)

The ALARMS button appears only when an alarm is present, and blinks (by alternating between normal and reverse video) to draw attention to a diagnostic condition. Pressing the ALARMS button takes you to the corresponding tab for additional information.

Auto, Stop/Immediate Stop

The Auto and Stop keys will be presented as radio buttons within the persistent key display area. The selected key will be black.

The chiller will stop when the Stop key is touched, entering the Run Unload mode. An informational screen will be displayed for 5 seconds indicating that a second depression of an "Immediate Stop" key during this time period will result in an immediate stop. Pressing the "Immediate Stop" key while the immediate stop screen is displayed, will cause the unit to stop immediately, skipping operational pumpdown.



NOTICE:

Equipment Damage!

Do NOT enable/disable the chiller by removing water flow or equipment damage can occur.

Touching the Auto key will arm the chiller for active cooling if no diagnostic is present. As in UCP2, a separate action must be taken to clear active diagnostics.

The AUTO and STOP, take precedence over the ENTER and CANCEL keys. (While a setting is being changed, AUTO and STOP keys are recognized even if ENTER or CANCEL has not been pressed.)

Diagnostic Annunciation

When an active diagnostic is present, an Alarms key will be added to the persistent display area. This key will serve two purposes. The first purpose will be to alert the operator that a diagnostic exists. The second purpose is to provide navigation to a diagnostic display screen.



A complete listing of diagnostics and codes is included in the Diagnostic Section.

Manual Override Exists

An indicator to present the presence of a manual override will share space with the Alarms enunciator key. While a manual override exists, the space used for the Alarms key will be occupied by a "Manual" icon, that will display solid inverse color similar to the appearance of the Alarms enunciator. An Alarm will take precedence of the Manual, until the reset of active alarms, at which point the Manual indicator would re-appear if such an override exists.

If the Manual indicator is pressed, the Manual Control Settings screen will be displayed.

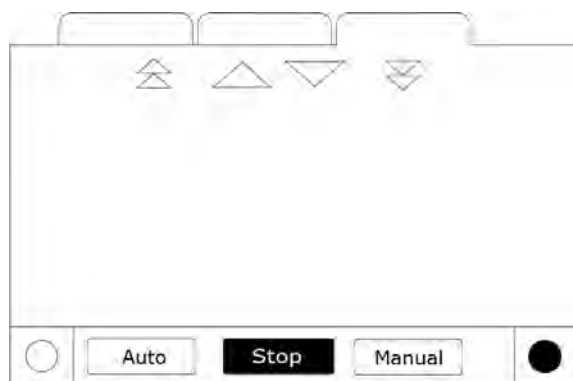

Main Screen

The Main screen is a "dashboard" of the chiller. High level status information is presented so that a user can quickly understand the mode of operation of the chiller.

The Chiller Operating Mode will present a top level indication of the chiller mode (i.e. Auto, Running, Inhibit, Run Inhibit, etc.). The "additional info" icon will present a subscreen that lists in further detail the subsystem modes.

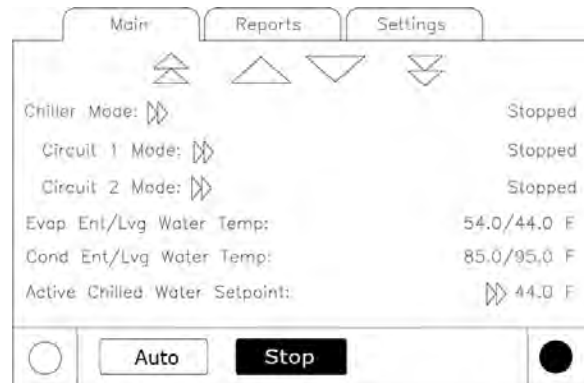

The Main screen shall be the default screen. After an idle time of 30 minutes the CH530 shall display the Main screen with the first data fields.

The remaining items (listed in the following table) will be viewed by selecting the up/down arrow icons.

Table 63. Main Screen Data Fields Table

Description	Units	Resolution
Chiller Mode (>> submodes)	enumeration	
Circuit Mode (>> submodes)	enumeration	
Circuit 1 Mode (>> submodes)	enumeration	
Circuit 2 Mode (>> submodes)	enumeration	
Evap Ent/Lvg Water Temp	F / C	0.1
Active Chilled Water Setpoint (>>source)	F / C	0.1
Active Hot Water Setpoint (>>source)	F / C	0.1
Active Demand Limit Setpoint (>>source)	%	1
Outdoor Air Temperature	F / C	0.1
Software Type	enumeration	Scroll
Software Version		X.XX

Chiller Operating Mode

The machine-operating mode indicates the operational status of the chiller. A subscreen with additional mode summary information will be provided by selection of an additional information icon (>>). The operating mode line will remain stationary while the remaining status items scroll with the up/down arrow keys.

Active Chilled Water Setpoint

The active chilled water setpoint is the setpoint that is currently in use. It results from the logical hierarchy of setpoint arbitration by the main processor. It will be displayed to 0.1 degrees Fahrenheit or Celsius.

Touching the double arrow to the left of the Active Chilled Water Setpoint will take the user to the active chilled water setpoint arbitration sub-screen.

Active Chilled Water Subscreen

The active chilled water setpoint is that setpoint to which the unit is currently controlling. It is the result of arbitration between the front panel, BAS, schedule, external, and auxiliary setpoints (schedule and auxiliary not shown in the following diagram), which in turn may be subjected to a form of chilled water reset.



The chilled water reset status area in the right most column will display one of the following messages

- Return
- Constant Return
- Outdoor
- Disabled

The left column text “Front Panel”, “BAS” or “Schedule”, “External”, “Auxiliary”, “Chilled Water Reset”, and “Active Chilled Water Setpoint” will always be present regardless of installation or enabling those optional items. In the second column “-----” will be shown if that option is Not Installed, otherwise the current setpoint from that source will be shown.

Setpoints that are adjustable from the DynaView™ (Front Panel Chilled Water Setpoint, Auxiliary Chilled Water Setpoint) will provide navigation to their respective setpoint change screen via a double-arrow to the right of the setpoint source text. The setpoint change screen will look identical to the one provided in the Chiller Setpoints screen. The “Back” button on the setpoint change screen provides navigation back to the setpoint arbitration screen.

The “Back” button on the setpoint arbitration screen provides navigation back to the chiller screen.

Other Active Setpoints

The Active Demand Limit Setpoint will behave the same was as the Active Chilled Water Setpoint, except that its units are in percent and there is an Ice Building source in place of the Auxiliary source. Front Panel Demand Limit Setpoint will provide navigation to its setpoint change screen.

Password-Protected Settings

The user can change some settings from the DynaView™ display on the chiller. Other settings are password-protected. In order to change these setting the password is 314.

Settings Screen

The Settings screen provides a user the ability to adjust settings necessary to support daily tasks. The layout provides a list of sub-menus, organized by typical subsystem. This organization allows each subscreen to be shorter in length which should improve the user's navigation.

A sample Settings screen is a list of the subsystems as shown below.



Settings Sub-Screens - Table of Text, Data, Ranges, etc.

Below is the table of text, resolution, field size, enumerated selections, and data for Settings subscreens. See the functional specification “CGAM Settings and Setpoints” for further information such as ranges and operation.

Table 64. Unit

Description	Resolution or (Enumerations)	Units
Front Panel Cool	Cool	Enum
Front Panel Chilled Water Setpt:	+ or - XXX.X	Temperature
Auxiliary Chilled Water Setpt:	+ or - XXX.X	Temperature
Front Panel Demand Limit Setpt:	XXX	Percent
Front Panel Ice Build Cmd:	On/Auto	Enum
Front Panel Ice Term Setpt:	+ or - XXX.X	Temperature
Front Panel Noise Stb Cmd:	On/Auto	Enum
Setpoint Source:	(BAS/Ext/FP, Ext/ Front Panel, Front Panel), BAS/Ext/FP	Enum

Table 65. Feature settings

Description	Resolution or (Enumerations), Default	Units
Power-Up Start Delay:	10 seconds	Seconds (MM:SS)
Cool Low Ambient Lockout:	(Enable, Disable), Enable	Enum
Cool Low Ambient Lockout Stpt:	+ or - XXX.X	Temperature
Water Pump Off Delay:	1 minute	Minutes (HH:MM)
Ice Building:	(Enable, Disable), Disable	Enum
PHR Fan Control:	(Enable, Disable), Disable	Enum
Local Time of Day Schedule	Subscreen (see below)	
External/BAS	Subscreen (see below)	
Chilled Water Reset	Subscreen (see below)	

Table 66. External/BAS feature settings (subscreen of feature settings)

Description	Resolution or (Enumerations), Default	Units
Ext Chilled Setpt:	(Enable, Disable), Disable	Enum
Ext Demand Limit Setpoint:	(Enable, Disable), Disable	Enum
Max Capacity Debounce Time:	30 seconds	Seconds (MM:SS)
Limit Annunc Debounce Time:	30 seconds	Seconds (MM:SS)
LCI-C Diag Encoding:	(Text, Code) Text	Enum
LCI-C Diag Language:	(English, Selection 2, Selection 3) English (0)	Enum

Table 67. Chilled water reset feature settings (subscreen of feature settings)

Description	Resolution or (Enumerations), Default	Units
Chilled Water Reset:	(Const Return, Outdoor, Return, Disable), Disable	Enum
Return Reset Ratio:	XXX	Percent
Return Start Reset:	XXX.X	Temperature
Return Maximum Reset:	XXX.X	Temperature
Outdoor Reset Ratio:	XXX	Percent
Outdoor Start Reset:	XXX.X	Temperature
Outdoor Maximum Reset:	XXX.X	Temperature

Table 68. Control settings

Description	Resolution or (Enumerations), Default	Units
Cooling Design Delta Temp:	XXX.X	Delta Temperature
Heating Design Delta Temp:	XXX.X	Delta Temperature
Differential to Start:	XXX.X	Delta Temperature
Differential to Stop:	XXX.X	Delta Temperature
Staging Deadband Adjustment:	XXX.X	Delta Temperature
Capacity Control Softload Time:	120 seconds	Seconds (MM:SS)
Circuit Staging Option:	(Bal Starts/Hrs, Circuit 1 Lead, Circuit 2 Lead), Bal Starts/Hrs	Enum
Compressor Staging Option:	(Fixed, Bal Starts/Hrs)	Enum
Leaving Water Temp Cutout:	XX.X	Temperature
Low Refrigerant Temp Cutout:	XX.X	Temperature
Evap Flow Overdue Wait Time:	30 seconds	Seconds (MM:SS)
Disch Press Limit Setpt:	85%	Percent
Disch Press Limit Unload Setpt:	97%	Percent

Table 69. System manual control settings

Description	Resolution or (Enumerations), Default	Units	Monitor Value
Evap Water Pump	(Auto, On), Auto	Enum	1) Evap Flow status 2) Override Time Remaining
Clear Restart Inhibit Timer	(Clear Timer)		1) Restart Inhibit Time (composite value)
Capacity Control	(Auto, Manual) Auto	Enum	
Binding	Special	Special	None

Table 70. Circuit manual control settings

Description	Resolution or (Enumerations), Default	Units	Monitor Value
Front Panel Ckt Lockout	(Not Locked Out, Locked Out), Not Locked Out	Enum	
Cprsr A Lockout	(Not Locked Out, Locked Out), Not Locked Out	Enum	
Cprsr B Lockout	(Not Locked Out, Locked Out), Not Locked Out	Enum	

Table 70. Circuit manual control settings (continued)

Description	Resolution or (Enumerations), Default	Units	Monitor Value
Cprsr C Lockout	(Not Locked Out, Locked Out), Not Locked Out	Enum	
Manual EXV Control:	(Auto, Manual), Auto	Enum	
Manual EXV Position Cmd:	XXX	Percent	EXV Status Suction Pressure
Cooling EXV Manual Ctrl:	(Auto, Manual), Auto	Enum	
Cooling EXV Manual Position Cmd:	XXX	Percent	EXV Status Suction Pressure
Cprsr A Pumpdown	Status: (Avail, Not Avail, Pumpdown) Override Subscreen command buttons: (Abort, Pumpdown) - <i>button is either grayed out or not shown if not available</i>	Enum	Suction Pressure
Cprsr B Pumpdown	Status: (Avail, Not Avail, Pumpdown) Override Subscreen command buttons: (Abort, Pumpdown) - <i>button is either grayed out or not shown if not available</i>	Enum	Suction Pressure
Cprsr C Pumpdown	Status: (Avail, Not Avail, Pumpdown) Override Subscreen command buttons: (Abort, Pumpdown) - <i>button is either grayed out or not shown if not available</i>	Enum	Suction Pressure

Local Time of Day Schedule Screen

To access the optional Local Time of Day Schedule Screen it must be configured in TechView™. This option will then be shown under the Feature Settings screen.

This screen shows the overall feature enable/disable setting, plus a listing of all 10 events, including their event time and active days of the week.

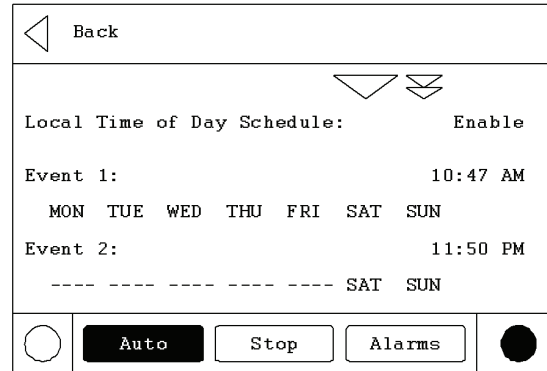

Local Settings Event Screen

This screen displays the details for a particular event, including the active days, event time, and the Local Schedule arbitrated setpoints. Selecting a given item will allow the user to modify it.

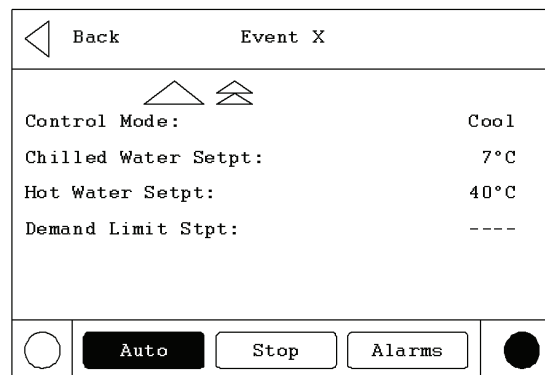
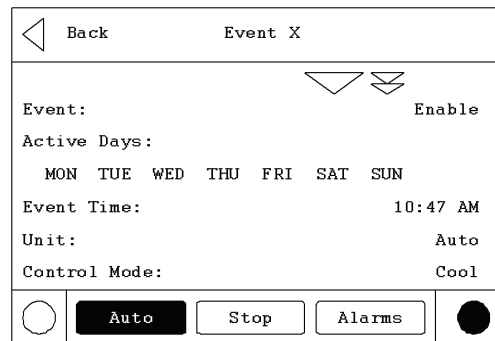

Event Enable/Disable Screen

Back Event X

Event: Enable

Disable

Enable

Press Button to Select

Auto Stop Alarms

Back Event X

Chilled Water Setpt: 7 C

Used Not Used

Enter Cancel

Press Arrows to Change

Press Enter to Save Change

Press Cancel to Ignore Change

Auto Stop Alarms

Event Active Days Screen

This screen is unusual because it does not use radio buttons, which only allow one active selection at a time. These buttons are more like “selection buttons” or check boxes. The user can select any combination of days, or none at all.

Back Event X

Active Days:

Monday Tuesday Wednesday

Thursday Friday Saturday

Sunday

Auto Stop Alarms

Event Time Screen

Back Event X

Event Time: 10:47 AM

Hours Minutes

Enter Cancel

Press Arrows to Change

Press Enter to Save Change

Press Cancel to Ignore Change

Auto Stop Alarms

Event Arbitrated Settings Screens

For analog setpoints, the screen is slightly different than the standard screen, because there are two additional buttons - “Used” and “Not Used”. Selecting “Used” will make the setting valid and allow the user to change the value. Selecting “Not Used” will make the setting invalid, and will not allow the user to change the value.

Table 71. Display settings

Description	Resolution or (Enumerations), Default	Units
Date Format	("mmm dd, yyyy", "dd-mmm-yyyy"), "mmm dd, yyyy"	Enum
Date ⁴		
Time Format	(12-hour, 24-hour), 12-hour	Enum
Time of Day ⁴		
Keypad/Display Lockout ³	(Enable, Disable), Disable	Enum
Display Units	(SI, English), English	Enum
Pressure Units	(Absolute, Gauge), Gauge	Enum
Local Atmospheric Pressure:	XXX.X	Pressure (always absolute)
Language ¹	(English, Selection 2, Selection 3), English (0)	Enum

- (1) Language choices are dependent on what the Service Tool has setup in the Main Processor. Get Radio Button names from Main Processor setups. Language selections will include English and qty 2 alternate as loaded by TechView™.
- (2) Temperatures will be adjustable to 0.1 deg F or C. The Main Processor will provide the minimum and maximum allowable value.
- (3) Enables a DynaView™ Lockout screen. All other screens time-out in 30 minutes to this screen. The DynaView™ Lockout Screen will have 0-9 keypad to permit the user to re-enter the other DynaView™ screens with a fixed password. See below for further details.
- (4) The Date and Time setup screen formats deviate slightly from the standard screens defined above. See the alternate screen layouts below.
- (5) Language shall always be the last setting listed on the Control Settings menu (which will also always be the last item listed on the Settings menu list). This will allow a user to easily find language selection if looking at an unrecognizable language.
- (6) The pump on mode terminates after 60 minutes.

Upon selecting a Settings list all setpoints available to change and the current value appear. Operator selects a setpoint by touching either the verbal description or setpoint value, causing the screen to switch to either Analog Settings Subscreen or Enumerated Settings Subscreen.

Analog Setting Subscreens

Analog Settings Subscreen displays the current value of the chosen setpoint in the upper ½ of the display. It is displayed in a changeable format consistent with its type. Binary setpoints are considered to be simple two state enumerations and will use radio buttons. Analog setpoints

Controls Interface

are displayed as spin buttons. The lower half of the screen is reserved for help screens.



All setpoint subscreens will execute the equivalent of a Cancel key if any display activities cause the subscreen to be left before a new setpoint is entered. E.g. If Alarms key is pressed before a new setpoint is entered, new setpoint will be cancelled. The same applies to any time-outs.

Pressing the Auto or Stop keys will not cause a cancel since the setpoint subscreen is not left on this action.

Enumerated Settings Subscreen

The enumerated setpoint subscreen has no cancel or enter key. Once a radio key is depressed the item is immediately set to the new enumeration value.

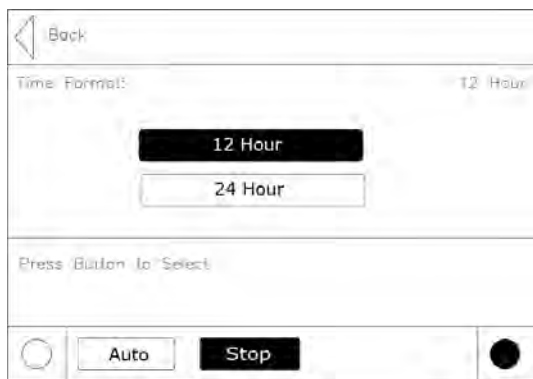

Mode Override Subscreens

The Mode Override subscreen has no cancel or enter key. Once a radio key is depressed that new value is immediately assumed.

Mode Override for Enumerated Settings is shown below:



Date/Time Subscreen

The setpoint screen for setting up the CH530 date is shown below: The user must select Day, Month, or Year and then use the up/down arrows to adjust.

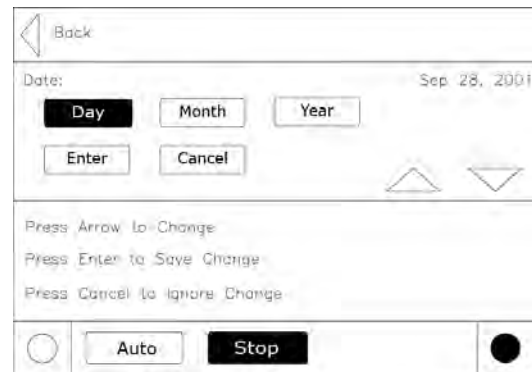

The setpoint screen for setting up the CH530 time with a 12 hour format is shown below. User must select Hour, or Minute, then use up/down arrows to adjust. Adjusting hours will also adjust am/pm.



Lockout Screen

The DynaView™ Display and Touch Screen Lock screen is shown. This screen is used if the Display and Touch Screen Lock feature is Enabled. Thirty minutes after the last key stroke this screen will be displayed and the Display and Touch Screen will be locked out until “159 Enter” is entered.

Until the proper password is entered there will be no access to the DynaView™ screens including all reports, all setpoints, and Auto/Stop/Alarms/Interlocks. The password “159” is not programmable from either DynaView™ or TechView™.

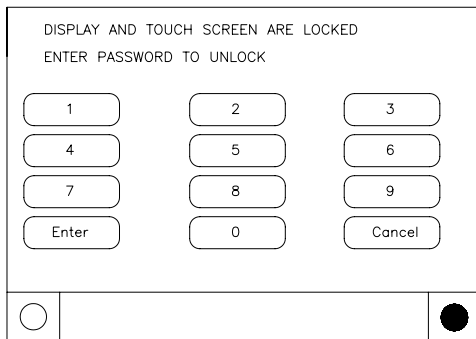

If the Display and Touch Screen Lock feature is Disabled, a similar screen including “Enter 159 to Unlock” will show if the MP temperature is approximately less than 32°F (0°C) and it has been 30 minutes after the last key stroke. Note: the main processor is equipped with an on-board temp sensor which enables the ice protection feature (OAT is not required).

Freezing rain can form on the touch panel and actuate the touch screen as the rain freezes on its surface. A specific pattern of key presses will avoid this issue.

Reports

The Reports tab will allow a user to select from a list of possible reports headings (i.e. Custom, ASHRAE Guideline 3, Refrigerant, etc.) Each report will generate a list of status items as defined in the tables that follows:



Historic Diagnostics are also included in this menu.

Table 72. Report name: system evaporator

Description	Resolution	Units
Evap Entering Water Temp:	+ or - XXX.X	Temperature
Evap Leaving Water Temp:	+ or - XXX.X	Temperature
Evap Pump Inverter 1 Run Cmd:	On, Off	Enumeration
Evap Pump 1 Command:	On, Off	Enumeration
Evap Pump 2 Command:	On, Off	Enumeration
Evap Water Flow Switch Status:	Flow, No Flow	Enumeration

Table 73. Report name: circuit evaporator

Description	Resolution	Units
Suction Pressure	XXX.X	Pressure
Suction Saturated Rfgt Temp:	+ or - XXX.X	Temperature
Suction Temperature:	+ or - XXX.X	Temperature
Evap Approach Temp:	+ or - XXX.X	Temperature
EXV Position Status:	XXX.X	Percent
Heating EXV Position Status:	XXX.X	Percent

Table 74. Report name: system condenser

Description	Resolution	Units
Outdoor Air Temperature:	+ or - XXX.X	Temperature
Heat Rcvy Entering Water Temp:	+ or - XXX.X	Temperature
Heat Rcvy Leaving Water Temp:	+ or - XXX.X	Temperature

Table 75. Report name: circuit condenser

Description	Resolution	Units
Discharge Pressure:	XXX.X	Pressure
Discharge Saturated Rfgt Temp:	+ or - XXX.X	Temperature
Discharge Temperature:	+ or - XXX.X	Temperature
Cond Approach Temp:	+ or - XXX.X	Temperature
Current Air Flow:	XXX.X	Percent

Table 76. Report name: system compressor

Description	Resolution	Units
Chiller Running Time:	XXXX:XX	hr:min

Table 77. Report name: circuit compressor

Description	Resolution	Units
Compressor A Starts:	XXXX	Integer
Compressor A Running Time:	XXXX:XX	hr:min
Compressor B Starts:	XXXX	Integer
Compressor B Running Time:	XXXX:XX	hr:min
Compressor C Starts:	XXXX	Integer
Compressor C Running Time:	XXXX:XX	hr:min

Table 78. Report name: system ASHRAE chiller log

Description	Resolution	Units
Current Time/Date:	XX:XX mmm dd, yyyy	Date / Time

Controls Interface

Table 78. Report name: system ASHRAE chiller log

Description	Resolution	Units
Chiller Mode:		Enum
Active Chilled Water Setpoint:	XXX.X	Temperature
Active Hot Water Setpoint:	XXX.X	Temperature
Evap Entering Water Temp:	XXX.X	Temperature
Evap Leaving Water Temp:	XXX.X	Temperature
Evap Water Flow Switch Status:		Enum
Outdoor Air Temperature:	XXX.X	Temperature
Active Demand Limit Setpoint:	XXX	Percent

Table 79. Report name: circuit ASHRAE chiller log

Description	Resolution	Units
Circuit Mode:		Enum
Suction Pressure:	XXX.X	Pressure
Suction Saturated Rfgt Temp:	XXX.X	Temperature
Evap Approach Temp:	XXX.X	Temperature
Discharge Pressure:	XXX.X	Pressure
Discharge Saturated Rfgt Temp:	XXX.X	Temperature
Cond Approach Temp:	XXX.X	Temperature
Compressor A Starts:	XXXX	Integer
Compressor A Running Time:	XX:XX	Hours: Minute
Compressor B Starts:	XXXX	Integer
Compressor B Running Time:	XX:XX	Hours: Minute
Compressor C Starts:	XXXX	Integer
Compressor C Running Time:	XX:XX	Hours: Minute

Power Up and Self Tests

Power-Up DynaView

DynaView™ will progress through three Power-Up screens:

First Screen, Application Status, Boot Software P/N, Self Test and Application Time Stamp.

This screen will display for 3-10 seconds. This screen will give the status of the Application software, the Boot Software P/N, display Self Test results and display the Application Part Number (CGAM 6200-0450-01). The contrast will also be adjustable from this screen. The message “Selftest Passed” may be replaced with “Err2: RAM Error” or “Err3: CRC Failure”.

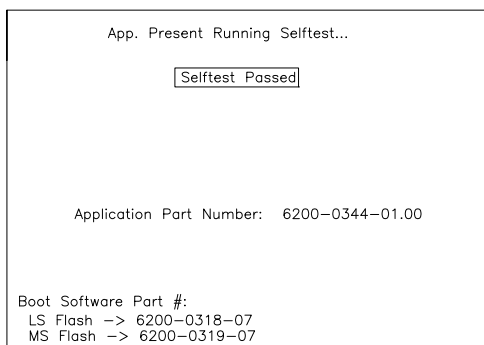

Display Formats

Temperature settings can be expressed in F or C, depending on Display Units settings.

Pressure settings can be expressed in psia, psig, kPaa (kPa absolute), or kPag (kPa gauge) depending on Display Units settings.

Dashes (“----”) appearing in a temperature or pressure report, indicates that the value is invalid or not applicable.

Languages

The languages for DynaView™ will reside in the main processor. The main processor will hold three languages, English, and two alternate languages. The service tool (TechView™) will load the main processor with user selected languages from a list of available translations.

TechView



TechView™ is the PC (laptop) based tool used for servicing Tracer CH530. Technicians that make any chiller control modification or service any diagnostic with Tracer CH530 must use a laptop running the software application “TechView.” TechView is a Trane application developed to minimize chiller downtime and aid the technicians understanding of chiller operation and service requirements.

Important: *Performing any Tracer CH530 service functions should be done only by a properly trained service technician. Please contact your local Trane service agency for assistance with any service requirements.*

TechView software is available via Trane.com. (<http://www.trane.com/COMMERCIAL/DesignAnalysis/TechView.aspx?i=1435>)

This download site provides a user the TechView installation software and CH530 main processor software that must be loaded onto your PC in order to service a CH530 main processor. The TechView service tool is used to load software into the Tracer CH530 main processor.

Minimum PC requirements to install and operate TechView

- Microsoft® Windows® XP Professional, Windows Vista Business or Windows 7 Enterprise operating system, Windows 10
- Internet Explorer 6.0 or higher
- USB 2.0 or higher
- Pentium II, III or higher processor
- 128Mb RAM minimum for TechView™, 1G recommended for total Windows system
- 1024 x 768 resolution of display
- CD-ROM (optional for copying TechView install to CD)
- 56K modem (optional for internet connection)
- ROVER USB-to-Serial (USB to 9-pin male)

Note: TechView™ was designed for the preceding listed laptop configuration. Any variation will have unknown results. Therefore, support for TechView is limited to only those operating systems that meet the specific configuration listed here. Only computers with a Pentium II class processor or better are supported; Intel Celeron, AMD, or Cyrix processors have not been tested.

TechView™ is also used to perform any CH530 service or maintenance function. Servicing a CH530 main processor includes:

- Updating main processor software
- Monitoring chiller operation
- Viewing and resetting chiller diagnostics
- Low Level Intelligent Device (LLID) replacement and binding
- Main processor replacement and configuration modifications
- Setpoint modifications
- Service overrides

TechView Software Download, Installation

This information can also be found at <http://www.trane.com/COMMERCIAL/DesignAnalysis/TechView.aspx?i=1435>.

1. Create a folder called "CH530" on your (C:\CH530) on your hard drive. This \CH530 folder is the standard recommended location for the installation file. Storing the installation file in this location helps you remember where it is stored and makes it easier for technical support personnel to assist you.
2. Click the link for the latest version on the TechView™ Software Download page. Enter your name, e-mail address and other required information. Click **Submit**.
3. A download link will be sent to the e-mail address provided. Before you click the link please note:

- Sent link may only be used one time.
- Internet options must be set correctly to allow download. To verify correct setting:
 - Open Internet Explorer Browser
 - Click **Tools**
 - Select **Internet Options**
 - Select **Security** tab
 - Click on **Internet** zone
 - Click **Custom Level** button
 - Scroll to **Downloads** section
 - Verify/Enable "Automatic prompting for file downloads"
 - Click **OK**
 - Click YES on warning window
 - Click Apply, then OK

Note: If this setting is incorrect, you may or may not receive an error message during download attempt.

4. Click the download link in the e-mail message.
 - If the download window does not open immediately, please look for a yellow highlighted message bar/line near the top of your browser. It may contain a message such as "To help protect your security, Internet Explorer blocked this site from downloading files to your computer. Click here for options..." Click on message line to see options.
 - When dialog box appears, click **Save** and navigate to the CH530 folder created in [Step 1](#). Click OK.
 - If you do not complete the download successfully, you will have to request another download link ([Step 2](#)).
5. Navigate to the CH530 folder created in [Step 1](#). Double-click the installation (.exe) file. The License Agreement dialog box appears.
6. Click **I Agree** after reviewing License Agreement. The **Choose Components** dialog box appears. All components are selected by default. (These are the actual MP versions for all units.) Deselect any components you do not want.

Note: Deselecting components reduces the size of the installed application.

7. Click **Install**. A progress meter dialog box appears. An information file appears when installation is complete.

Note: Techview requires a current version of JAVA. If you do not have the current release, TechView installation will be interrupted, and you will be provided with information for required JAVA software download. Once you have completed the JAVA installation, return to [Step 5](#) to restart installation.

Unit View

Unit view is a summary for the system organized by chiller subsystem. This provides an overall view of chiller operating parameters and gives you an “at-a-glance” assessment of chiller operation.

The Control Panel tab displays important operating information for the unit and allows you to change several key operating parameters. The panel is divided into four or more sub-panels (depending on the number of circuits in the unit).

The Operating Mode tab displays the unit, circuit and compressor top level operating modes.

The Hours and Starts tab displays the number a hours (total) a compressor has run and the number of times the compressor has started. This window plays a key role in evaluating maintenance requirements.

Upon successful Local Connect TechView™ will display UNIT VIEW. The Unit View displays the system, control point name, value and unit of measure. It reflects active setpoints and allows you to make changes.

CGAM Unit View is shown below:

Figure 70. Unit view

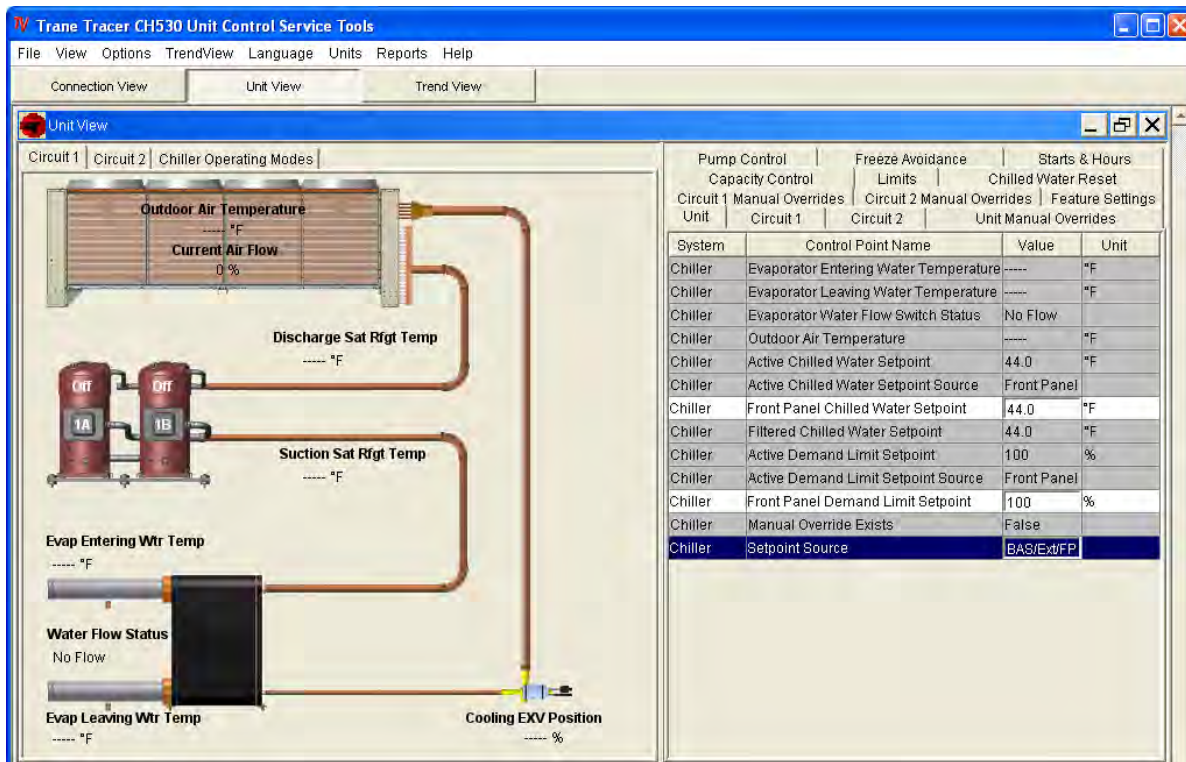

Unit View also displays, in real time, all non-setpoint data organized by tabs. As data changes on the chiller it is automatically updated in the Unit View.

Figure 71. Unit view tabs

Pump Control	Freeze Avoidance	Starts & Hours
Capacity Control	Limits	Chilled Water Reset
Circuit 1 Manual Overrides	Circuit 2 Manual Overrides	Feature Settings
Unit	Circuit 1	Circuit 2
		Unit Manual Overrides

Table 80. Unit view tabs - detail

Tab	Item	Type	Units	Min Value	Max Value	Default Value
Unit Tab						
Evaporator Entering Water Temperature	Status	Temp	(°C)			
Evaporator Leaving Water Temperature	Status	Temp	(°C)			
Evaporator Water Flow Switch Status	Status	Flow/No Flow				

Circuit/Compressor Lockout

In order to lock out a circuit the user must go to the Unit View/Circuit 1 Manual Overrides Tab and then select the Front Panel Lockout for circuit 1 and/or circuit 2. It is also possible to lockout individual compressors from the same Circuit 1 Manual Overrides Tab in this view.

Table 80. Unit view tabs - detail (continued)

Tab	Item Type	Units	Min Value	Max Value	Default Value
Outdoor Air Temperature	Status	Temp (°C)			
Active Chilled Water Setpoint	Status	Temp (°C)			
Active Chilled Water Setpoint Source	Status	BAS/External/Front Panel/Auxiliary/Schedule			
Front Panel Chilled Water Setpoint	Setting	Temp °C (°F)	Capacity Control Chilled Water Setpoint	20°C (68°F)	6.7°C (44°F)
BAS Chilled Water Setpoint	Status	Temp (°C)			
Local Schedule Chilled Water Setpoint	Status	Temp (°C)			
External Chilled Water Setpoint	Status	Temp (°C)			
Auxiliary Chilled Water Setpoint	Status	Temp (°C)			
Filtered Chilled Water Setpoint	Status	Temp (°C)			
Active Demand Limit Setpoint	Status	%			
Active Demand Limit Setpoint Source	Status	BAS/External/Front Panel/Auxiliary/Schedule			
Front Panel Demand Limit Setpoint	Setting	%	Smallest Capacity Step	100	100
BAS Demand Limit Setpoint	Status	%			
Local Schedule Demand Limit Setpoint	Status	%			
External Demand Limit Setpoint	Status	%			
Active Ice Building Command	Status	Off /On			
Front Panel Ice Building Command	Setting	Auto	No Request	Ice Building Request	No Request
Active Ice Termination Setpoint	Status	Temp (°C)			
Front Panel Ice Termination Setpoint	Setting	Temp °C (°F)	-6.67°C (20°F)	0°C (32°F)	-2.78°C (27°F)
Manual Override Exists	Status	False/True			
Setpoint Source	Setting	BAS/Ext/FP			
Circuit 1 Tab					
Suction Pressure	Status	Pressure (kPa)			
Discharge Pressure	Status	Pressure (kPa)			
Suction Saturated Refrigerant Temperature	Status	Temp (°C)			
Suction Temperature	Status	Temp (°C)			
Discharge Saturated Refrigerant Temperature	Status	Temp (°C)			
Discharge Temperature	Status	Temp (°C)			
Condenser Approach Temperature	Status	Temp (°C)			
Evaporator Approach Temperature	Status	Temp (°C)			
EXV Position Status (%)	Status	%			
Circuit 2 Tab					
Suction Pressure	Status	Pressure (kPa)			
Discharge Pressure	Status	Pressure (kPa)			
Suction Saturated Refrigerant Temperature	Status	Temp (°C)			
Suction Temperature	Status	Temp (°C)			
Suction Superheat	Status	Delta Temp (°C)			
Discharge Saturated Refrigerant Temperature	Status	Temp (°C)			
Discharge Temperature	Status	Temp (°C)			
Condenser Approach Temp	Status	Temp (°C)			
Evaporator Approach Temp	Status	Temp (°C)			
EXV Position Status (%)	Status	%			
Unit Manual Overrides Tab					



Controls Interface

Table 80. Unit view tabs - detail (continued)

Tab	Item Type	Units	Min Value	Max Value	Default Value
Manual Capacity Control	Setting	Auto/Manual			
Manual Capacity Control Command	Setting	Unload/Hold/Load			
Clear Restart Inhibit	Setting				
Maximum Restart Inhibit Time Remaining	Status	Time (Seconds to MM:SS)			
Manual Evaporator Pump Control	Setting	Auto/On			
Manual Evaporator Pump Override Time	Status	Time (Seconds to MM:SS)			
Circuit 1 Manual Overrides Tab					
Front Panel Lockout	Setting	Not Locked/Locked			
Compressor A Lockout	Setting	Not Locked/Locked			
Compressor B Lockout	Setting	Not Locked/Locked			
Compressor C Lockout	Setting	Not Locked/Locked			
Manual EXV Control	Setting	Auto/Manual			
Manual EXV Control Percent	Setting	%			
Compressor 1A Pumpdown Command	Setting	Abort			
Compressor 1A Pumpdown Status	Status	Available/Not Available/ In Progress/Inhibited			
Compressor 1B Pumpdown Command	Setting	Abort/Start			
Compressor 1B Pumpdown Status	Status	Available/Not Available/ In Progress/Inhibited			
Compressor 1C Pumpdown Command	Setting	Abort/Start			
Compressor 1C Pumpdown Status	Status	Available/Not Available/ In Progress/Inhibited			
Suction Pressure	Status	Pressure (kPa)			
Circuit 2 Manual Overrides Tab					
Front Panel Lockout	Setting	Not Locked/Locked	Auto	Stop	Auto
Compressor A Lockout	Setting	Not Locked/Locked	Auto	Stop	Auto
Compressor B Lockout	Setting	Not Locked/Locked	Auto	Stop	Auto
Compressor C Lockout	Setting	Not Locked/Locked	Auto	Stop	Auto
Manual EXV Control	Setting	Auto/Manual			
Manual EXV Control Percent	Setting	%			
Compressor 2A Pumpdown Command	Setting	Abort/Start			
Compressor 2A Pumpdown Status	Status	Available/Not Available/ In Progress/Inhibited			
Compressor 2B Pumpdown Command	Setting	Abort/Start			
Compressor 2B Pumpdown Status	Status	Available/Not Available/ In Progress/Inhibited			
Compressor 2C Pumpdown Command	Setting	Abort/Start			
Compressor 2C Pumpdown Status	Status	Available/Not Available/ In Progress/Inhibited			
Suction Pressure	Status	Pressure (kPa)			
Feature Settings Tab					
Local Atmospheric Pressure	Setting	Pressure (kPa)	68.9 kPa	110.3 kPa	101.4 kPa
Power-Up Start Delay	Setting	Time (Seconds)	0	600	0
Operational Pumpdown Temperature Setpoint	Setting	Temp °C (°F)	-26°C (-14.8°F)	-10°C (14°F)	-17.78°C (0°F)
External Chilled Water Setpoint	Setting	Disable/Enable			Disabled
External Demand Limit Setpoint	Setting	Disable/Enable			Disabled
Limit Annunciation Debounce Time	Setting	Time (Seconds)	0s	3600s	1200s
Maximum Capacity Annunciation Debounce Time	Setting	Time (Seconds)	0s	3600s	1200s

Table 80. Unit view tabs - detail (continued)

Tab	Item Type	Units	Min Value	Max Value	Default Value
Ice Building Feature	Setting	Disable/Enable			Disabled
EXV Recalibration Time	Setting	Time (Seconds)	?	?	
Capacity Control Tab					
Cooling Design Delta Temperature	Setting	Delta Temp °C (°F)	1°C (1.8°F)	12°C (21.6°F)	5.56°C (10°F)
Differential To Start	Setting	Delta Temp °C (°F)	1°C (1.8°F)	6°C (10.8°F)	2.78°C (5°F)
Differential To Stop	Setting	Delta Temp °C (°F)	1°C (1.8°F)	7°C (12.6°F)	2.78°C(5°F)
Staging Deadband Adjustment	Setting	Delta Temp °C (°F)	-1°C (-1.8°F)	5°C (9°F)	0°C (0°F)
Circuit Staging Option	Setting	Balance Strts-Hrs/Circuit 1 Lead/ Circuit 2 Lead			Balance Starts Hours
Compressor Staging Option	Setting	Fixed Sequence/ Balanced Strts-Hrs			Fixed Sequence
Compressor Start Delay Time	Setting	Time (Seconds)	0 s	600 s	60 s
Capacity Control Softload Time	Setting	Time (Seconds)	0 s	3600 s	900 s
Limits Tab					
Cooling Low Ambient Lockout	Setting	Disable/Enable			Enabled
Cooling Low Ambient Lockout Setpoint	Setting	Temp °C (°F)	-20°C (-4°F)	20°C (68°F)	-10°C (14°F)
Discharge Pressure Limit Setpoint	Setting	%	80%	120%	85%
Discharge Pressure Limit Unload Setpoint	Setting	%	90%	120%	97%
Restart Inhibit Free Starts	Setting	Starts			2
Restart Inhibit Start To Start Time	Setting	Time (Minutes)			6 min
Chilled Water Reset Tab					
Chilled Water Reset Type	Setting	Disable/Return/Outdoor Air/Constant			
Return Reset Ratio	Setting	%	10%	120%	50%
Return Start Reset	Setting	Delta Temp °C (°F)	2.22°C (36°F)	16.67°C (62°F)	5.55°C (42°F)
Return Maximum Reset	Setting	Delta Temp °C (°F)	0°C (32°F)	11.11°C (52°F)	2.78°C (37°F)
Outdoor Reset Ratio	Setting	%	-80%	80%	10%
Outdoor Start Reset	Setting	Temp °C (°F)	10°C (50°F)	54.44°C (130°F)	32.22°C (90°F)
Outdoor Maximum Reset	Setting	Delta Temp °C (°F)	0°C (32°F)	11.11°C (52°F)	2.78°C (37°F)
Cooling Design Delta Temperature	Setting	Delta Temp °C (°F)	1°C (33.8°F)	12°C (53.6°F)	5.56°C (42°F)
Pump Control Tab					
Evaporator Water Flow Switch Status	Status	No Flow/Flow			
Evap Pump Inverter 1 Run Command	Status	Off/On			
Evaporator Pump 1 Command	Status	Off/On			
Evaporator Pump 2 Command	Status	Off/On			
Evap Pump Off Delay	Setting	Time (Minutes)	0 min	30 min	1 min
Evap Flow Overdue Wait Time	Setting	Time (Seconds)	300 s	3600 s	1200 s
High Evaporator Water Temp Setpoint	Setting	Temp °C (°F)			55°C
Freeze Avoidance Tab					
Leaving Water Temp Cutout	Setting	Temp °C (°F)	-21.7°C (-7°F)	4.4°C (40°F)	3.3°C (38°F)
Low Refrigerant Temperature Cutout	Setting	Temp °C (°F)	-29.4°C (-21°F)	2.22°C (36°F)	-3.3°C (26°F)
Evaporator Pump Freeze Avoidance	Setting	Disable/Enable			Enabled
Evap Pump Freeze Avoidance Adaptive Learning	Setting	Fixed/Adaptive			Enabled
Evap Pump Freeze Avoidance Time Constant	Setting	Time (minutes)	2 min	360 min	10 min
Evap Pump Freeze Avoidance Temp Margin	Setting	Delta Temp °C (°F)	0°C (32°F)	5°C (41°F)	2°C (35.6°F)
Starts and Hours Tab					
Chiller Running Time	Status	Time (Sec to HH:MM)			
Compressor 1A Starts	Status	Starts			



Controls Interface

Table 80. Unit view tabs - detail (continued)

Tab	Item	Type	Units	Min Value	Max Value	Default Value
Compressor 1A	Running Time	Status	Time (Sec to HH:MM)			
Compressor 1B	Starts	Status	Starts			
Compressor 1B	Running Time	Status	Time (Sec to HH:MM)			
Compressor 1C	Starts	Status	Starts			
Compressor 1C	Running Time	Status	Time (Sec to HH:MM)			
Compressor 2A	Starts	Status	Starts			
Compressor 2A	Running Time	Status	Time (Sec to HH:MM)			
Compressor 2B	Starts	Status	Starts			
Compressor 2B	Running Time	Status	Time (Sec to HH:MM)			
Compressor 2C	Starts	Status	Starts			
Compressor 2C	Running Time	Status	Time (Sec to HH:MM)			
Evaporator Water Pump 1	Starts	Status	Starts			
Evaporator Water Pump 1	Running Time	Status	Time (Sec to HH:MM)			
Evaporator Water Pump 1	Starts	Status	Starts			
Evaporator Water Pump 1	Running Time	Status	Time (Sec to HH:MM)			
Heat Recovery Tab						
Partial heat recovery (PHR) Fan Control		Setting	Disable/Enable			
PHR Leaving Water Temperature Setpoint		Setting	Temp (°C)			
PHR Leaving Water Temperature Adjustment		Setting	Delta Temp (°C)			
Generic Monitoring Tab						
Generic Temp Sensor		Status	Temp (°C)			
Generic Pressure Sensor		Status	Pressure (kPa)			
Generic Analog Monitor		Status	Current (mA)			
Generic Low Volt Monitor		Setting	Open/Closed			
Generic High Volt Monitor		Setting	Off/On			

The items that can be modified show up in white. The items that cannot be modified show up in gray.

Figure 72. Fields in white

Unit	Circuit 1	Circuit 2	Unit Manual Overrides	
System	Control Point Name		Value	Unit
Chiller	Evaporator Entering Water Temperature		----	*F
Chiller	Evaporator Leaving Water Temperature		----	*F
Chiller	Evaporator Water Flow Switch Status		No Flow	
Chiller	Outdoor Air Temperature		----	*F
Chiller	Active Chilled Water Setpoint		44.0	*F
Chiller	Active Chilled Water Setpoint Source		Front Panel	
Chiller	Front Panel Chilled Water Setpoint		44.0	*F
Chiller	Filtered Chilled Water Setpoint		44.0	*F
Chiller	Active Demand Limit Setpoint		100	%
Chiller	Active Demand Limit Setpoint Source		Front Panel	
Chiller	Front Panel Demand Limit Setpoint		100	%
Chiller	Manual Override Exists		False	
Chiller	Setpoint Source		BAS/Ext/FP	

To change the setpoint enter a new value for the setpoint into the text field.

Figure 73. Change setpoint

Chiller	Front Panel Chilled Water Setpoint	42	*F
---------	------------------------------------	----	----

If the entered value is outside the given range, the background turns red.

Figure 74. Change out of range

Chiller	Active Demand Limit Setpoint Source	Front Panel	
Chiller	Front Panel Demand Limit Setpoint	250	%
Chiller	Manual Override Exists	False	

If the value entered is not valid, an error message will display and the change will not occur.

Figure 75. Setpoint change failed

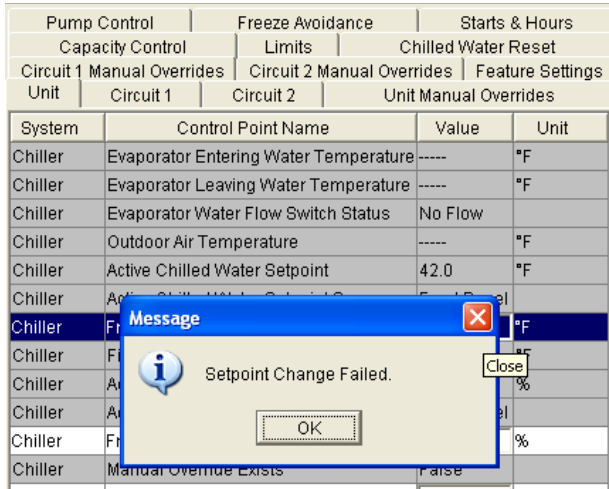
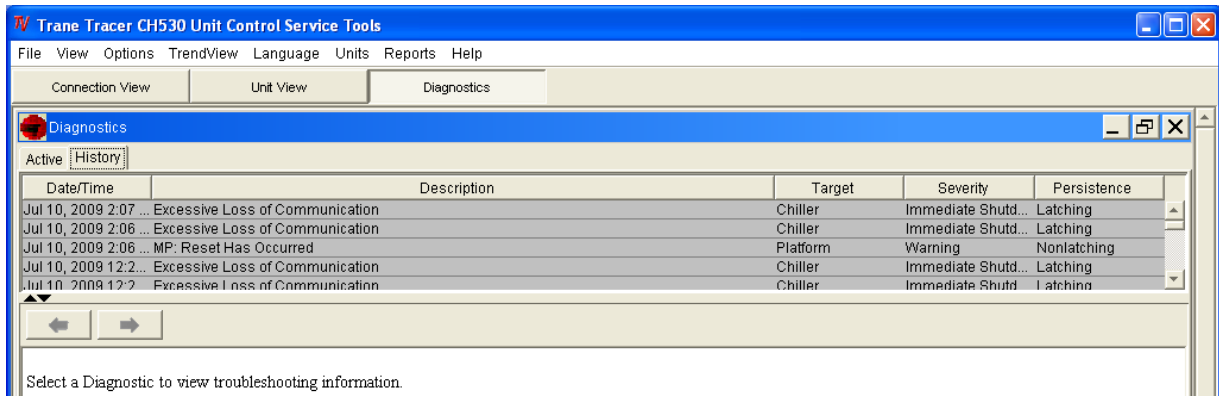

Figure 76. Diagnostic view



Configuration View

This view is under the CH530 tab and displays the active configuration and allows you to make changes to the unit configuration. Configuration View allows you to define the chiller's components, ratings, and configuration settings. These are all values that determine the required installed devices, and how the chiller application is run in the main processor. For example, a user may set an option to be installed with Configuration View, which will require devices to be bound using Binding View. And when the main processor runs the chiller application, the appropriate steps are taken to monitor required inputs and control necessary outputs.

Any changes made in the Configuration View, on any of the tabs, will modify the chiller configuration when you click on the Load Configuration button (located at the base of the window). The Load Configuration button uploads the new configuration settings into the main processor.

Selecting the Undo All button will undo any configuration setting changes made during the present TechView™

Diagnostics View

This window lists the active and inactive (history) diagnostics. There can be up to 60 diagnostics, both active and historic. For example, if there were 5 active diagnostics, the possible number of historic diagnostics would be 55. You can also reset active diagnostics here, (i.e., transfer active diagnostics to history and allow the chiller to regenerate any active diagnostics).

Resetting the active diagnostics may cause the chiller to resume operation.

The Active and History diagnostics have separate tabs. A button to reset the active diagnostics displays when either tab is selected.

connection and since the last time the Load Configuration button was selected.

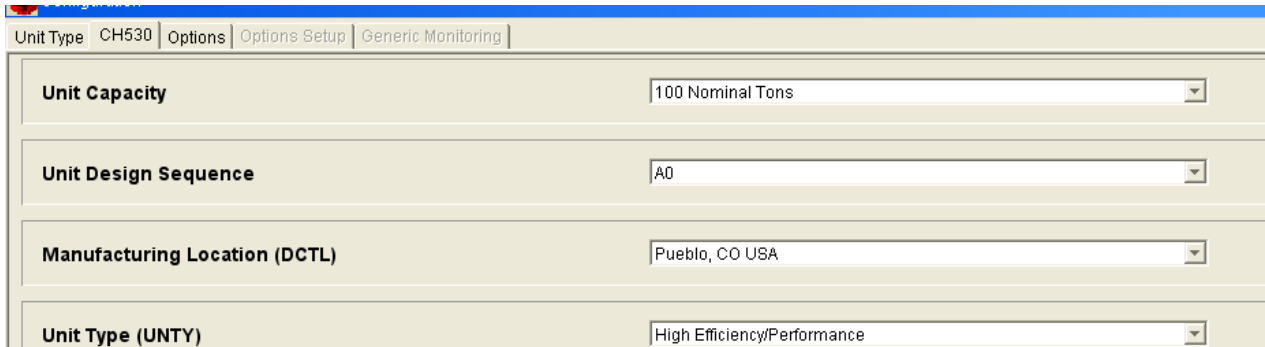
Figure 77. Configuration view – CH530 tab

Table 81. Configuration view items - CH530 tab

Item	Description
Basic Product Line	CGAM - Air-Cooled Scroll Packaged Chiller
	020 Nominal Tons
	023 Nominal Tons (TAI, EPL only)
	026 Nominal Tons
	030 Nominal Tons
	035 Nominal Tons
	039 Nominal Tons (EPL only)
	040 Nominal Tons
	045 Nominal Tons (EPL only)
	046 Nominal Tons (TAI, EPL only)
	052 Nominal Tons
	060 Nominal Tons
	070 Nominal Tons
080 Nominal Tons	
090 Nominal Tons	
100 Nominal Tons	
110 Nominal Tons	
120 Nominal Tons	
Unit Design Sequence	Factory Assigned
Manufacturing Location	Epinal, France
	Pueblo, USA
	Taicang, China
	Curitiba, Brazil
Unit Type	Standard Efficiency/Performance (EPL only)
	High Efficiency/Performance
Sound Package	High Duty (EPL and TAI only)
	Standard Noise
	Low Noise
Supply Power Frequency	60 Hz
	50 Hz
Unit Application	Standard Ambient (EPL and TAI only)
	Low Ambient (EPL and TAI only)
	High Ambient (EPL and TAI only)
	Wide Ambient
Heat Recovery	No Heat Recovery
	Partial Heat Recovery w/ Fan Control
	Partial Heat Recovery w/o Fan Control (EPL and TAI only)
Evaporator Pump Control	No Pump Flow Control
	Single Pump Fixed Speed (TAI, EPL only)
	Single Pump Variable Speed (TAI, EPL only)
	Dual Pump Fixed Speed (TAI, EPL only)
	Dual Pump Variable Speed

A couple of additional tabs in Configuration View allow you to change other unit configuration options using the Options tab and the Options Setup tab. The features that are installed on the Options Tab will control what is displayed on the Options Setup tab.

Figure 78. Configuration view — options tab

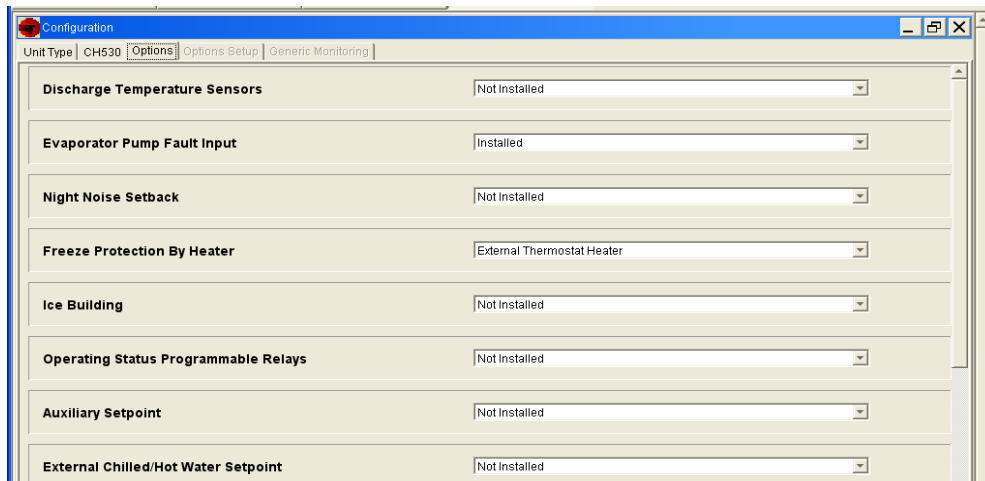

Figure 79. Configuration view — options setup tab



Software View

Software view allows you to verify the version of chiller software currently running on the DynaView™ and

download a new version of chiller software to the DynaView™.

You can also add up to two available languages to load into the DynaView™. Loading an alternate language file allows the DynaView™ to display its text in the selected alternate language, English will always be available.

Figure 80. Software view

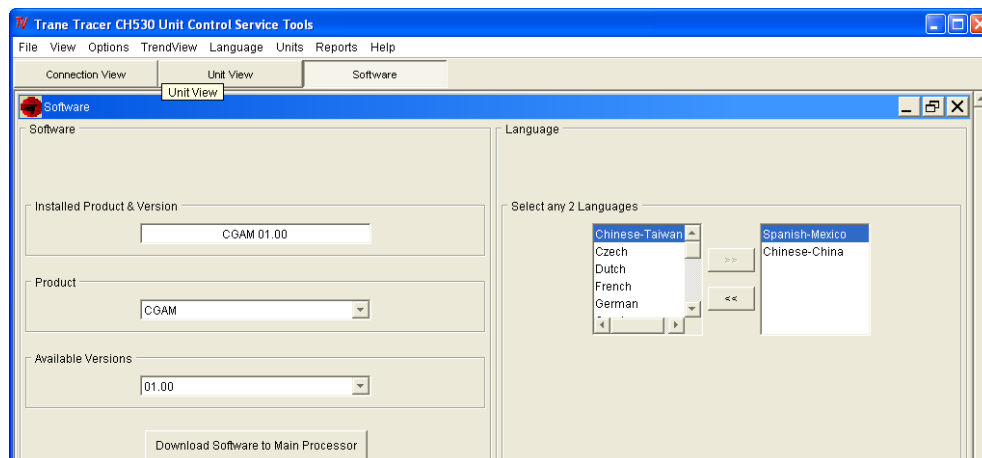

Binding View

Binding View allows you to assess the status of the network and all the devices connected as a whole, or the status of individual devices by using status icons and function buttons.

Binding View is essentially a table depicting what devices and options are actually discovered on the network bus (and their communication status) versus what is required to support the configuration defined by the feature codes

Figure 81. Binding view

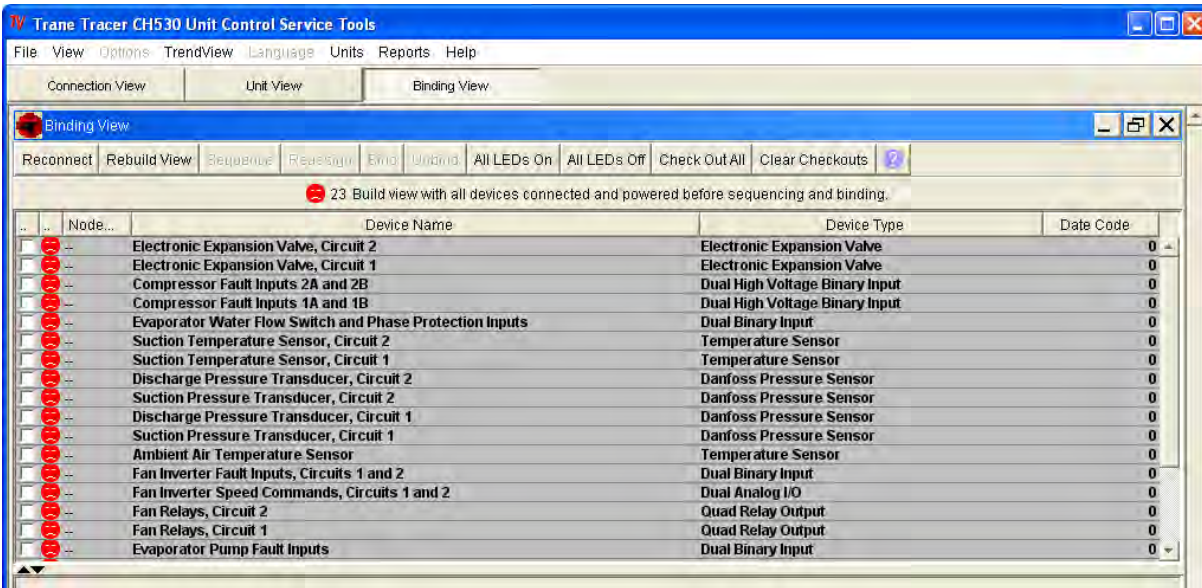

Replacing or Adding Devices

If a device is communicating but incorrectly configured, it might not be necessary to replace it. If the problem with the device is related to communication, attempt to rebind it, and if the device becomes correctly configured, it will then communicate properly.

If a device that needs to be replaced is still communicating, it should be unbound. Otherwise, it will be necessary to rebuild the CH530 network image for Binding View to discover that it has been removed. An unbound device stops communicating and allows a new device to be bound in its place.

It is good practice to turn the power off while detaching and attaching devices to the CH530 network. Be sure to keep power on the service tool computer. After power is restored to the CH530 network, the reconnect function in Binding View restores communication with the network. If the service tool computer is turned off, you must restart TechView™ and Binding View.

If a device is not communicating, the binding function displays a window to request manual selection of the device to be bound. Previously-selected devices are deselected when the function starts. When manual selection is confirmed, exactly one device must be selected; if it is the correct type, it is bound. If the desired

and categories. Binding View allows you to add, remove, modify, verify, and reassign devices and options in order to match the configuration requirements.

Whenever a device is installed, it must be correctly configured to communicate and to function as intended. This process is called binding. Some features of Binding View are intended to serve a second purpose; that is diagnosing problems with communication among the devices.

device cannot be selected or if multiple devices are accidentally selected, you can close the manual selection window by clicking on No and repeat the bind function.



Pre-Start Checkout

Upon completion of installation, complete the CGAM Installation Completion Check Sheet and Request for Trane Service checklist in chapter [“Log and Check Sheet,”](#) p. 146.

Important: *Start-up must be performed by Trane or an agent of Trane specifically authorized to perform start-up and warranty of Trane products. Contractor shall provide Trane (or an agent of Trane specifically authorized to perform start-up) with notice of the scheduled start-up at least two weeks prior to the scheduled start-up.*



Start-Up and Shutdown

Important: Initial unit commissioning start-up must be performed by Trane or an agent of Trane specifically authorized to perform start-up and warranty of Trane products. Contractor shall provide Trane (or an agent of Trane specifically authorized to perform start-up) with notice of the scheduled start-up at least two weeks prior to the scheduled start-up.

Start-Up

NOTICE:

Equipment Damage!
Ensure that the oil sump heaters are connected properly and are operating properly for a minimum of 24 hours before starting. Failure to do so may result in equipment damage.

If required, once the system has been operating for approximately 30 minutes and has become stabilized, complete the remaining start-up procedures, as follows:

1. Check the evaporator refrigerant pressure and the condenser refrigerant pressure under Refrigerant Report on the CH530 TechView™.
- Note:** The pressures are referenced to sea level (14.6960 psia). This value is adjustable in TechView.
2. Check the EXV sight glasses after sufficient time has elapsed to stabilize the chiller. The refrigerant flow past the sight glasses should be clear. Bubbles in the refrigerant indicate either low refrigerant charge or excessive pressure drop in the liquid line or a stuck open expansion valve. A restriction in the line can sometimes be identified by a noticeable temperature differential between the two sides of the restriction. Frost will often form on the line at this point. Proper refrigerant charges are shown in General Data tables.

Important: A clear sight glass alone does not mean that the system is properly charged. Also check system subcooling, liquid level control and unit operating pressures.

If chiller is limited by any limiting conditions, contact local Trane service organization for more information.

Seasonal Unit Start-Up Procedure

1. Verify/close all drain valves.
2. Service the auxiliary equipment according to the start-up/maintenance instructions provided by the respective equipment manufacturers.
3. Remove all air from the system (including each pass). Close the vents in the evaporator chilled water circuits.
4. Open all valves in evaporator chilled water circuits.

5. If evaporator was previously drained, vent and fill evaporator and chilled water circuit. When all air is removed (including each pass), install vent plugs in evaporator water boxes.

NOTICE:

Equipment Damage!
Ensure that the oil sump heaters have been operating for a minimum of 24 hours before starting. Failure to do so may result in equipment damage.

Seasonal Unit Shutdown

1. Perform normal unit stop sequence using <Stop> key.
Note: Starter disconnect switch must remain closed to provide power to compressor oil sump heaters.
2. Verify that compressor oil sump heaters are installed tightly around compressor. Energize and verify heaters are operational using a temperature probe. See [Table 82, p. 124](#). Install jumper across thermostat and verify current flow.

NOTICE:

Equipment Damage!
If the chiller evaporator or evaporator water piping is drained of water, the evaporator immersion heater must be de-energized. Failure to de-energize the heater will cause it to burn out.

Table 82. Freeze protection heater summary^(a)

Heater	Thermostat	Jumper	Heater Description	Heaters
Evap and Water Pipe Heaters	5S1	5X1-2 to 5X1-3	Evaporator	5E1
			Evap Entering Water	5E4, 5E18
			Evap Leaving Water	5E5, 5E19
			Water Pump Piping	5E6, 5E14
			Partial Heat Recovery (optional)	5E10, 5E11, 5E16, 5E17
			Expansion Tank (included with optional pump package)	
Pump Package (optional)	5S2	5X2-1 to 5X2-2	Water Pump Piping	5E13, 5E15
Buffer Tank (optional)	5S3	Across thermostat	Buffer Tank	5E2, 5E8, 5E12, 5E13

(a) Not all heaters are present on all unit configurations. See schematics and component locations in CGAM-SVE01*-EN.

Note: See [“Ambient Freeze Avoidance,” p. 69](#) for more information.

3. Once the unit is secured, perform maintenance identified in [“Maintenance,” p. 128](#).

Sequence of Operation

This section will provide basic information on chiller operation for common events. With microelectronic controls, ladder diagrams cannot show today's complex logic, as the control functions are much more involved than older pneumatic or solid state controls.

Adaptive control algorithms can also complicate the exact sequence of operations. This section illustrates common control sequences.

Software Operation Overview

The Software Operation Overview shown in Figure 82 is a diagram of the five possible software states. This diagram can be thought of as a state chart, with the arrows and arrow text depicting the transitions between states.

- The text in the circles is the visible top level operating mode displayed on DynaView Main tab.
- The shading of each software state circle corresponds to the shading on the time lines that show the state the chiller is in.

There are five generic states that the software can be in:

- Power Up
- Stopped
- Starting
- Running
- Stopping

Figure 82. Chiller state chart

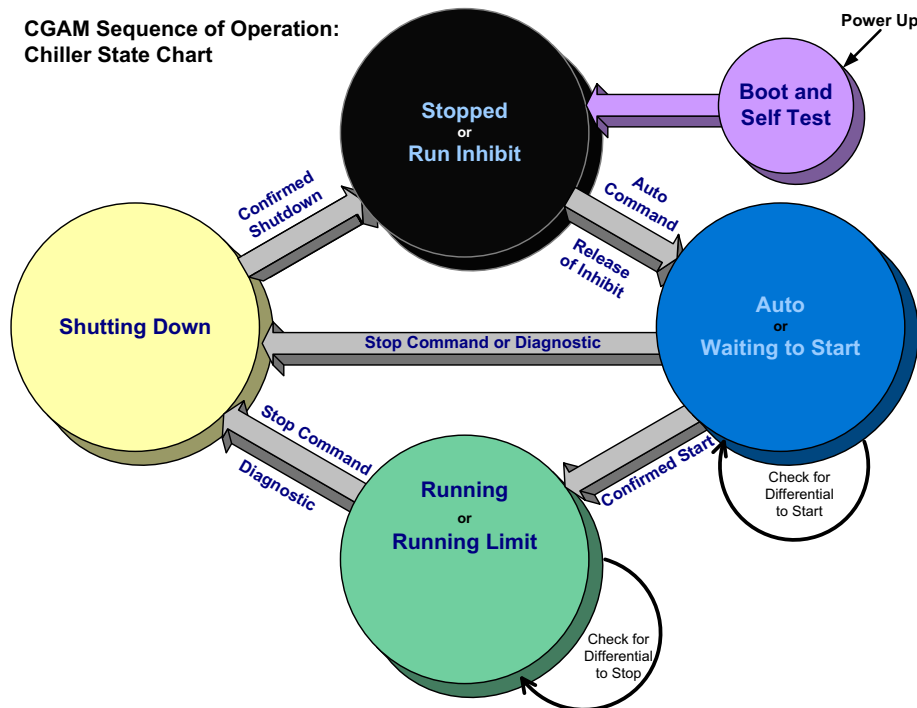

Power Up

The Power up chart shows the respective DynaView screens during a power up of the main processor. This process takes from 30 to 45 seconds depending on the number of installed Options. On all power ups, the software model will always transition through the

'Stopped' Software state independent of the last mode. If the last mode before power down was 'Auto', the transition from 'Stopped' to 'Starting' occurs, but it is not apparent to the user.

Figure 83. Power up

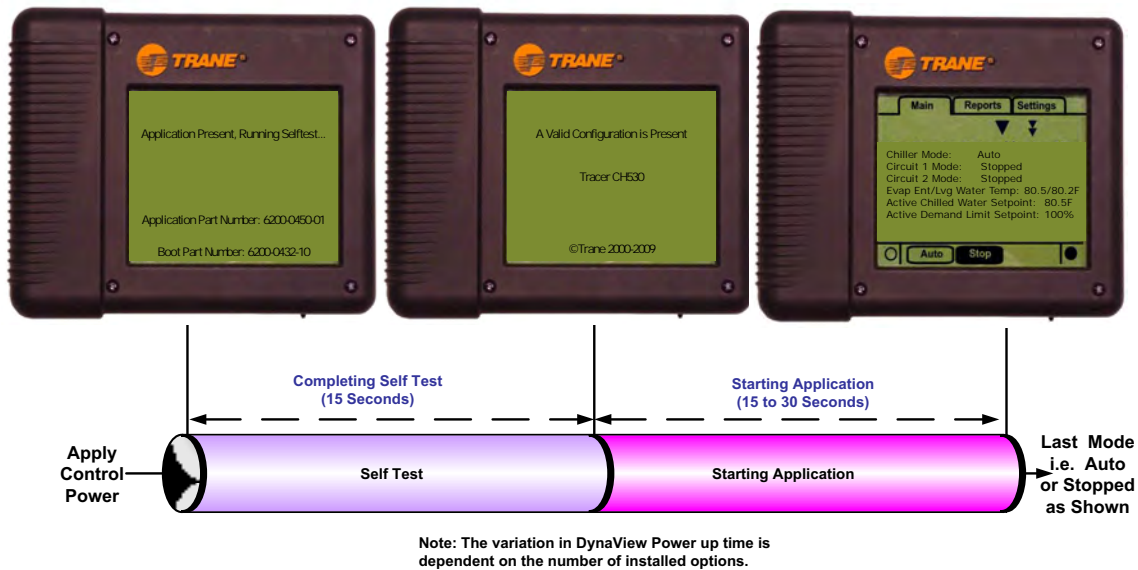

Power Up to Starting

Power up to starting diagram shows timing from a power up event to energizing the first compressor. The shortest allowable time would be under the following conditions:

- No motor restart inhibit
- Evaporator Water flow occurs quickly with pump on command

- Power up Start Delay setpoint set to 0 minutes
- Need to cool (differential to start) already exists

The above conditions would allow for a minimum power up to starting the first compressor time of about 85 seconds, depending on options installed.

Figure 84. Power up to starting

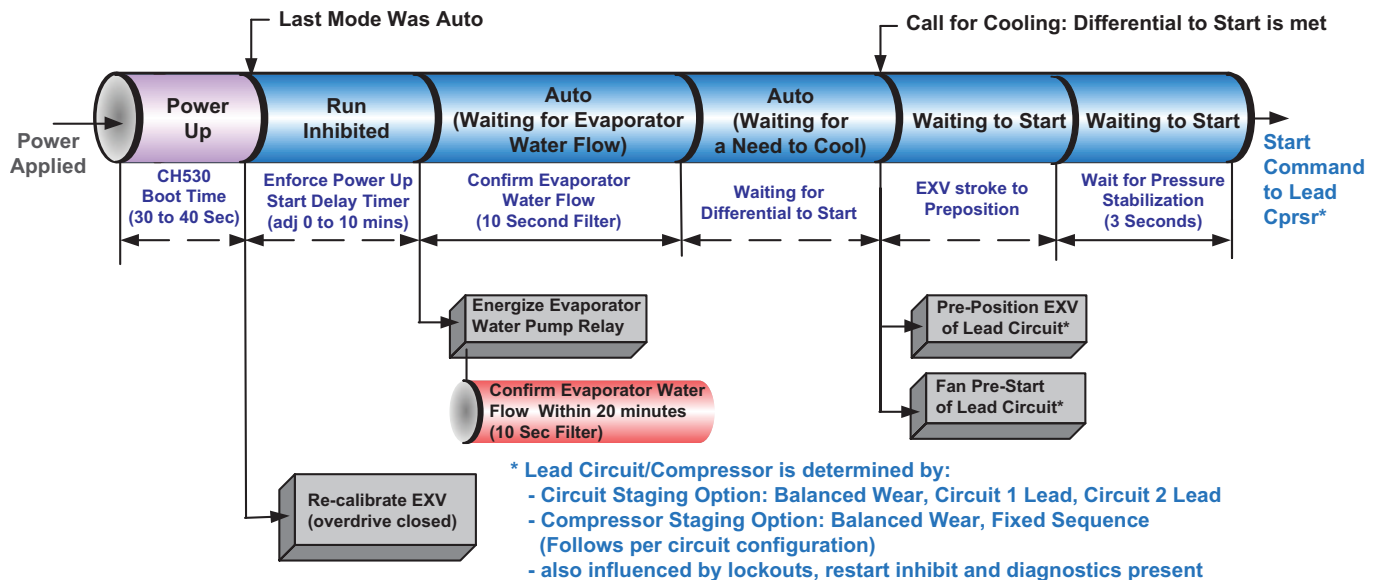

Stopped to Starting

The stopped to starting diagram shows the timing from a stopped mode to energizing the compressor. The shortest allowable time would be under the following conditions:

- No motor restart inhibit
- Evaporator Water flow occurs quickly with pump on command

- Need to cool (differential to start) already exists.

The above conditions would allow the compressor to start in about 35 seconds.

Figure 85. Stopped to starting

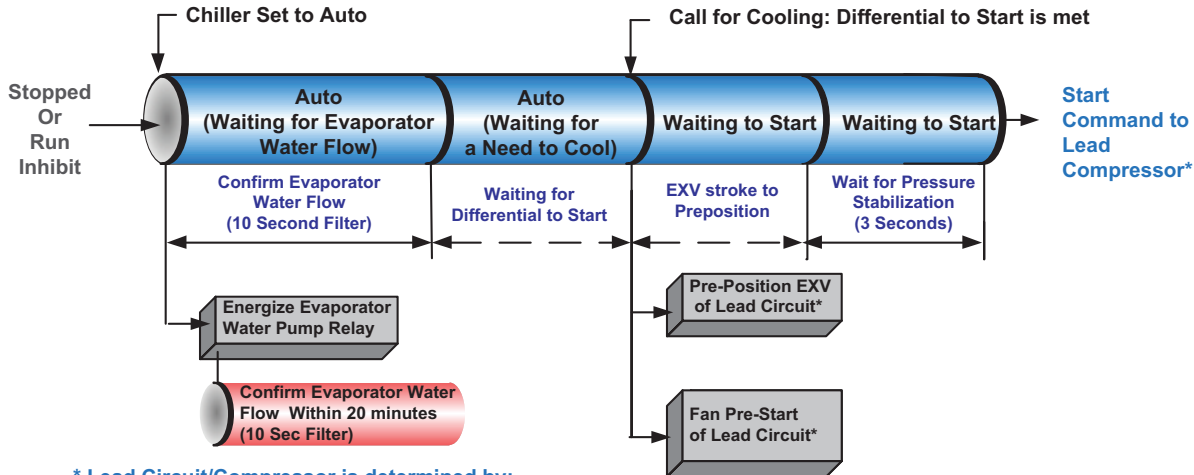

* Lead Circuit/Compressor is determined by:

- Circuit Staging Option: Balanced Wear, Circuit 1 Lead, Circuit 2 Lead
- Compressor Staging Option: Balanced Wear, Fixed Sequence (Follows per circuit configuration)
- also influenced by lockouts, restart inhibit and diagnostics present

Normal Shutdown to Stopped

Figure 86 shows transition from Running through a Normal (friendly) Shutdown. Dashed lines on top attempt to show final mode if you enter stop via various inputs.

Figure 86. Normal shutdown to stopped or run inhibit

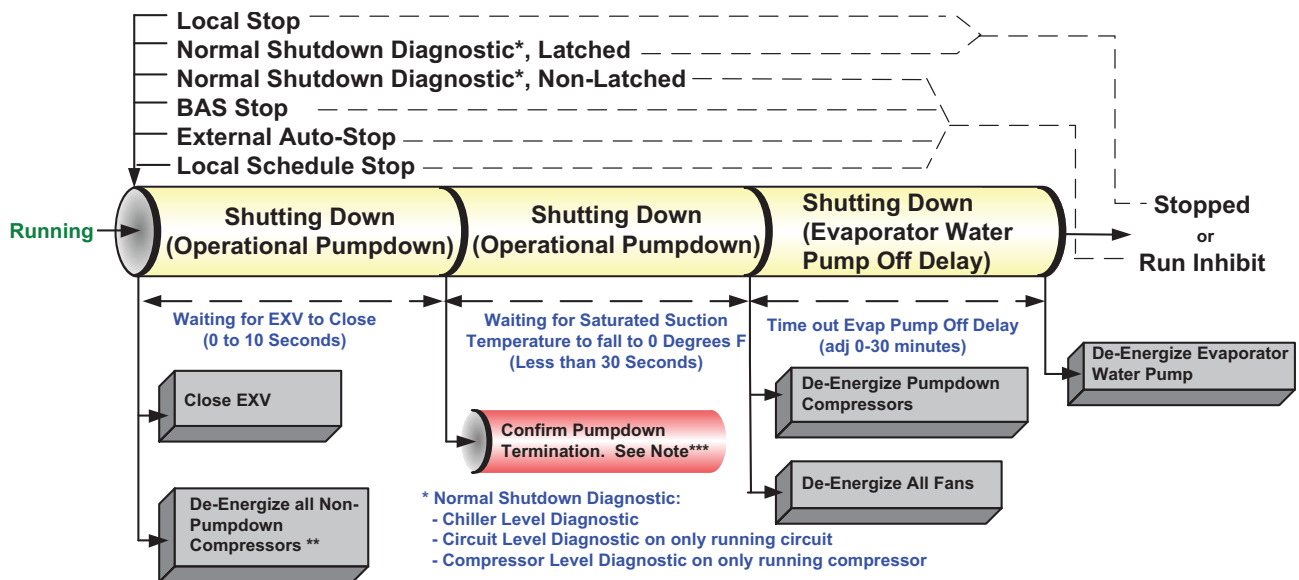



Maintenance

⚠ WARNING

Hazardous Voltage - Pressurized Burning Fluid!

Failure to follow all electrical safety precautions could result in death or serious injury.

Compressors on 110 and 120 ton, extra efficiency units, have strong permanent magnet motors that have the capability to generate voltage during situations when the refrigerant charge is being migrated. This potential will be present at the motor terminals and at the load side of compressor contactors.

Before removing compressor terminal box cover for servicing, or servicing power side of control panel, **CLOSE COMPRESSOR DISCHARGE SERVICE VALVE and disconnect all electric power including remote disconnects. Follow lockout/tagout procedures to ensure the power cannot be inadvertently energized.**

The compressor contains hot, pressurized refrigerant. Motor terminals act as a seal against this refrigerant. Care should be taken when servicing **NOT** to damage or loosen motor terminals.

Do not operate compressor without terminal box cover in place.

⚠ WARNING

Hazardous Voltage!

Failure to disconnect power before servicing could result in death or serious injury. Disconnect all electric power, including remote disconnects before servicing. Follow proper lockout/tagout procedures to ensure the power can not be inadvertently energized.

Perform all maintenance procedures and inspection at the recommended intervals. This will prolong the life of the chiller and minimize the possibility of malfunctions.

Use an "Operator's Log" to record the unit's operating history. The log serves as a valuable diagnostic tool for service personnel. By observing trends in operating conditions, an operator can anticipate and prevent problem situations before they occur.

If the unit is not operating properly during maintenance inspections, see "[Diagnostics](#)," p. 133.

Recommended Maintenance

Weekly

Verify that compressor oil sump heaters are connected tightly around the compressor.

After the chiller has been operating for approximately 30 minutes and the system has stabilized, check the operating

pressures and temperatures and complete the following checks:

Check the evaporator and condenser refrigerant pressures in the Refrigerant Report menu of the CH530 display. Pressures are referenced at sea level (14.6960 psia).

Check the electronic expansion valve sight glasses.

Note: *The electronic expansion valve is commanded closed at unit shutdown and if the unit is off, there will be no refrigerant flow through the sight glasses. Only when a circuit is running will refrigerant flow be present.*

The refrigerant flow through the sight glasses should be clear. Bubbles in the refrigerant indicate either low refrigerant charge or excessive pressure drop in the liquid line. A restriction in the line can sometimes be identified by a noticeable temperature differential between the two sides of the restriction. Frost may often form on the liquid line at this point. Correct refrigerant charges are shown in the General Data Tables.

Important: *A clear sight glass alone does not mean that the system is properly charged. Also check the system superheat, subcooling and unit operating pressures.*

For more information, see "[Refrigerant and Oil Charge Management](#)," p. 129.

Monthly

1. Complete all weekly maintenance procedures.
2. Measure and record the evaporator superheat.
3. Measure and record the system subcooling.

Annual

1. Complete all weekly and monthly maintenance checks.
2. Check the oil level and refrigerant charge. Routine changing of oil is not required.
3. Have a qualified laboratory perform a compressor oil analysis to determine system moisture content and acid level. This analysis is a valuable diagnostic tool.
4. Contact a qualified service provider to leak test the chiller, check operating and safety controls, and to inspect electrical components for proper operation. Leak testing may be accomplished using soap solution or with electronic or ultrasonic leak detectors.
5. Inspect all piping components for leaks and damage. Clean all water strainers.

NOTICE:

Equipment Damage!

If the CGAM chiller evaporator or evaporator water piping is drained of water, the evaporator immersion heater must be de-energized. Failure to de-energize the heater will cause it to burn out.

6. Clean and repaint any components that show corrosion.
7. Clean the condenser coils per “[Condenser Maintenance](#),” p. 130.

⚠ WARNING

Rotating Components!

Failure to disconnect power before servicing could result in rotating components cutting and slashing technician which could result in death or serious injury. Disconnect all electric power, including remote disconnects before servicing. Follow proper lockout/tagout procedures to ensure the power can not be inadvertently energized.

8. Clean the condenser fans. Check the fan assemblies for proper clearance in the fan shroud openings and for motor shaft misalignment or abnormal end-play, vibration and noise.
9. Manually rotate the condenser fans to ensure that there is proper clearance on the fan shroud openings. Inspect the entire system for unusual conditions.

Refrigerant and Oil Charge Management

Proper oil and refrigerant charge is essential for proper unit operation, unit performance, and environmental protection. Only trained and licensed service personnel should service the chiller.

[Table 83](#) lists baseline measurements for CGAM units running at AHRI standard operating conditions. If chiller measurements vary significantly from values listed below, problems may exist with refrigerant and oil charge levels. Contact your local Trane office.

Note: *Low temperature applications units will have values that vary from [Table 83](#). Contact your local Trane office for more information.*

Table 83. Typical CGAM baselines (AHRI conditions)

Measurement	Baseline
Evaporator Pressure	120 psig
Evaporator Approach	5-10°F
EXV Position	40-50% open
Evaporator delta T	10°F
Evaporator Superheat	12°F
Condenser Pressure	420-440 psia
Condensing Approach Temperature	25°F
Subcooling	15-20°F
Compressor Discharge Temperature	63° or more
Compressor Suction Temperature	20° or more
Compressor RLA	100%

Lubrication System

Oil Level

Oil should also be visible in the sight glass when the compressor is running. When operating, each compressor in a tandem or trio set may have a different oil level.

To check compressor oil level, refer to the label near the compressor sight glass. The compressor(s) must be off. Wait three minutes. With tandem or triple compressors the oil level will equalize after shutdown. Compressor oil level should be clearly visible within the sight glass when the compressors are off.

Important: *If oil level is low, contact your local Trane office. Verify that ONLY Trane OIL00080 is used.*

Oil Testing

Use Trane Oil Testing Kit KIT06815 only for testing lubricating oil in the Model CGAM chiller. Note that the POE oil used in this product is very hygroscopic and easily absorbs and retains moisture. The acceptable moisture content is less than 100 ppm and acceptable acid level is less than 0.5 TAN. Note that refrigerant and moisture is very difficult to remove from this oil using vacuum. Also note that once the seal on a container of POE oil is opened, the oil must be used.

In the event of a compressor failure, always test the oil with an acid test kit to determine whether the compressor failure was mechanical or electrical. This is important because it dictates correct cleanup procedure.

Condenser Maintenance

Microchannel Condensers

For proper operation, microchannel condenser coils must be cleaned regularly. Eliminate pollution and other residual material help to extend the life of the coils and the unit.

Regular coil maintenance, including annual cleaning, enhances the unit's operating efficiency by minimizing compressor head pressure and amperage draw. The condenser coil should be cleaned at minimum once each year, or more if the unit is located in a "dirty" or corrosive environment.

Microchannel Condenser Coil Cleaning

NOTICE:

Equipment Damage!

Do not use detergents to clean coils. Use clean water only. Use of detergents on coils could cause damage to coils.

Cleaning with cleansers or detergents is strongly discouraged due to the all-aluminum construction. Water should prove sufficient. Any breach in the tubes can result in refrigerant leaks.

⚠ WARNING

Hazardous Voltage!

Disconnect all electric power, including remote disconnects before servicing. Follow proper lockout/tagout procedures to ensure the power can not be inadvertently energized. Failure to disconnect power before servicing could result in death or serious injury.

1. Disconnect Power to the unit.

⚠ WARNING

No Step Surface!

Failure to follow instruction below could result in death or serious injury. Do not walk on the sheet metal drain pan. Walking on the drain pan could cause the supporting metal to collapse, resulting in the operator/technician to fall.

Important: Bridging between the main supports required before attempting to enter the unit. Bridging may consist of multiple 2 by 12 boards or sheet metal grating.

2. Use a soft brush or vacuum to remove base debris or surface loaded fibers from both sides of the coil.

Note: When possible, clean the coil from the opposite direction of normal air flow (inside of unit out) to push debris out.

3. Using a sprayer and water ONLY, clean the coil following the guidelines below.
 - a. Sprayer nozzle pressure should not exceed 580 psi.
 - b. The maximum source angle should not exceed 25° to the face of the coil. See Figure 87. For best results spray the microchannel perpendicular to face of the coil.
 - c. Spray nozzle should be approximately 1"-3" from the coil surface.
 - d. Use at least a 15° fan type of spray nozzle.

Figure 87. Sprayer source angle

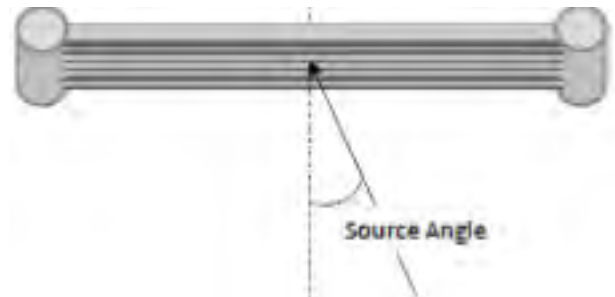

Note: To avoid damage from the spray wand contacting the coil, make sure the 90° attachment does not come in contact with the tube and fin as abrasion to the coil could result.

Repair/Replacement of Microchannel Coil

Microchannel coils are considerably more robust in design than tube and fin condenser coils, however they are not indestructible. When damage or a leak occurs, contact your local Trane office.

Round Tube Plate Fin Condensers

RTPF Condenser Coil Cleaning

⚠ WARNING

Hazardous Chemicals!

Coil cleaning agents can be either acidic or highly alkaline and can burn severely if contact with skin occurs. Handle chemical carefully and avoid contact with skin. ALWAYS wear Personal Protective Equipment (PPE) including goggles or face shield, chemical resistant gloves, boots, apron or suit as required. For personal safety refer to the cleaning agent manufacturer's Materials Safety Data Sheet and follow all recommended safe handling practices. Failure to follow all safety instructions could result in death or serious injury.

Clean the condenser coils at least once a year or more frequently if the unit is in a "dirty" environment. A clean condenser coil will help to maintain chiller operating efficiency. Follow the detergent manufacturer's instructions to avoid damaging the condenser coils.

To clean the condenser coils use a soft brush and a sprayer such as a garden pump type or a high-pressure type. A high quality detergent such as Trane Coil Cleaner (Part No. CHM-00255) is recommended.

See RTAC-SVG01B-EN for maintenance and cleaning procedures.

Note: *If detergent mixture is strongly alkaline (pH value greater than 8.5, an inhibitor must be added).*

Evaporator Maintenance

NOTICE:

Equipment Damage!

The factory-installed immersion heater must be de-energized if the BPHE evaporator is drained of water for any reason. Failure to de-energize the immersion heater will cause it to burn out.

The Trane Model CGAM liquid chiller uses a brazed plate heat exchanger (BPHE) evaporator with factory-installed electronic flow switch (IFM efector) that is positioned in the evaporator water pipe. The evaporator inlet also includes a factory-installed immersion heater for freeze protection and a water strainer that must be kept in place to keep debris out of the evaporator.

Note: *Strainer maintenance is critical to proper operation and reliability. Any particles larger than 1mm entering the BPHE evaporator may cause the evaporator to fail, requiring replacement.*

Acceptable BPHE evaporator water flow rate is 1.5 to 3.6 GPM per nominal unit ton capacity. To maintain 54-44°F in/out chilled water temperatures, the nominal water flow rate is 2.4 GPM/ton.

Minimum water flow rate must be maintained to avoid laminar flow, potential evaporator freezing, scaling and poor temperature control. The microprocessor and capacity control algorithms are designed to take a 10 percent change in water flow rate per minute while maintaining a $\pm 2^{\circ}\text{F}$ (1.1°C) leaving water temperature control accuracy. The chiller tolerates up to 30 percent per minute water flow variation as long as the flow is equal to or greater than minimum flow requirements.

Maximum water flow is 18 feet per second. Flow rates greater than this will cause excessive erosion.

The BPHE evaporator is difficult to clean should it become plugged with debris. Indications of a plugged BPHE evaporator include "wet" suction due to lack of heat exchange, loss of superheat control, depressed discharge superheat, compressor oil dilution and/or starvation and premature compressor failure.

Water Strainer Maintenance

For units with optional pump package, the factory-installed water strainer is a Y-type design with a cylindrical sieve.

Figure 88. Y type strainer — units with optional pump package

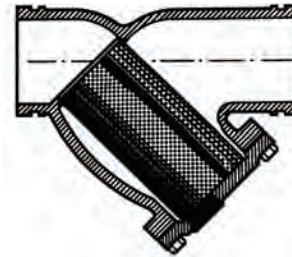

An in-line strainer with a V-shaped sieve is used for units that do not have factory-installed pump package option.

Figure 89. In-line strainer — units without optional pump package

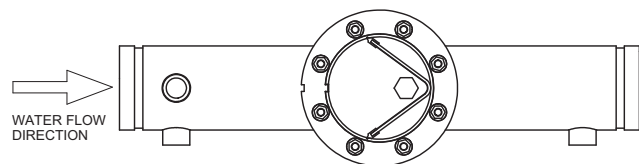

The strainer is equipped with a blow-down port. The strainer is a 16 mesh (approximately 1 mm) material.

For maximum efficiency, a differential pressure gauge installed across the inlet and outlet will indicate pressure loss due to clogging and may be used as a guide to determine when cleaning is required. The taps for the pressure gauges are included as standard from the factory.

Normally when differential pressure reaches 5-10psi, the screen must be cleaned. The strainer is equipped with a blow-down port on the cover plate. To clean open and flush out until any sediment is removed.

Pump Package Maintenance

Rust Prevention

Pumps not immediately placed into service, or removed from service and stored, must be properly prepared to prevent excessive rusting.

- Pump port protection plates must not be removed until the pump is ready to connect to the piping.
- Rotate the shaft periodically (at least monthly) to keep rotating element free and bearings fully functional.
- For long term storage (3 months or longer), prevent internal rust buildup and possibility of freezing by performing the following steps:
 - Remove the plugs at the top and bottom of the casing.
 - If water is to be drained:
 - Disconnect evaporator and piping heaters.
 - Drain or blow out all water.
 - As an optional step, it is acceptable to rustproof or pack the casing with moisture absorbing material and cover the flanges.

When returning pumps to service

- Remove drying agent from the pump, if used.
- Reinstall plugs at the top and bottom of the casing.
- If water had been drained:
 - Refill water.
 - Reconnect evaporator and piping heaters.



Diagnostics

Explanatory Comments

Diagnostic Text:

Black text is intended for use on TechView. It has no intrinsic length limit. It should contain few or no abbreviations.

Blue (italicized) text is intended for use on DynaView. It has a 40 character length limit for English and other European languages, based on 8 pixel character width (DynaView's display is 320 pixels wide). The text should be abbreviated as necessary to meet the length limit. Trane standard abbreviations or ASME standard abbreviations (ASME Y14.38-1999 or later) should be used wherever possible.

Orange (underlined) text is intended for use on LCI-C. LCI-C has a 28 character length limit for English and other European languages, based on one character per byte (LCI-C diagnostic text has a 28 byte limit). It should be abbreviated as necessary to meet the length limit. Trane standard abbreviations or ASME standard abbreviations (ASME Y14.38-1999 or later) should be used wherever possible. "Comm:" is the standard abbreviation for "Comm Loss:" in order to leave enough space for the rest of the diagnostic text.

Legacy Hex Code: Three digit hexadecimal code used on all past products to uniquely identify diagnostics.

Diagnostic Name and Source: Name of Diagnostic and its source. Note that this is the exact text used in the User Interface and/or Service Tool displays.

The following codes were added to cover the unmapped diagnostics:

- 6B6: Unknown Chiller Diagnostic
- 6B7: Unknown Compressor Diagnostic

Affects Target: Defines the "target" or what is affected by the diagnostic. Usually either the entire **Chiller**, or a particular **component** is affected by the diagnostic (the same one as the source), but in special cases functions are modified or disabled by the diagnostic. **None** implies that there is no direct affect to the chiller, sub components or functional operation.

Severity: Defines the severity of the above effect. **Immediate** means immediate shutdown of the effected portion, **Normal** means normal or friendly shutdown of the effected portion, **Special Mode** means a special mode of operation (limp along) is invoked, but without shutdown, and **Warning** means an Informational Note or Warning is generated.

Persistence: Defines whether or not the diagnostic and its effects are to be manually reset (Latched), or can be either manually or automatically reset (Nonlatched).

Active Modes [Inactive Modes]: States the modes or periods of operation that the diagnostic is active in and, as necessary, those modes or periods that it is specifically not active in as an exception to the active modes. The inactive

modes are enclosed in brackets, []. Note that the modes used in this column are internal and not generally announced to any of the formal mode displays

Criteria: Quantitatively defines the criteria used in generating the diagnostic and, if nonlatching, the criteria for auto reset. If more explanation is necessary a hot link to the Functional Specification is used.

Reset Level: Defines the lowest level of manual diagnostic reset command which can clear the diagnostic. The manual diagnostic reset levels in order of priority are:

Local and **Remote**. A diagnostic that has a reset level of Local, can only be reset by a local diagnostic reset command, but not by the lower priority remote Reset command whereas a diagnostic listed as Remote reset can be reset by either.

Help Text: Provides for a brief description of what kind of problems might cause this diagnostic to occur. Both control system component related problems as well as chiller application related problems are addressed (as can possibly be anticipated). These help messages will be updated with accumulated field experience with the chillers.

Main Processor Diagnostic

Table 84. Main processor diagnostics

Diagnostic Name	Affects	Severity	Persist-ence	Active Modes [Inactive Modes]	Criteria	Reset Level
BAS Communication Lost BAS Communication Lost BAS Communication Lost	Chiller	Special	NonLatch	All	Refer to the LCI-C interface for details on the LonTalk® interface. The BCI-C interface contains details on the BACnet® interface. Refer to setpoint arbitration to determine how setpoints and operating modes may be affected by the comm loss.	Remote
BAS Failed to Establish Communication BAS Failed to Establish Communication BAS Failed to Establish Comm	Chiller	Special	NonLatch	At power-up	Refer to the LCI-C interface for details on the LonTalk® interface. The BCI-C interface contains details on the BACnet® interface. Refer to setpoint arbitration to determine how setpoints and operating modes may be affected.	Remote
Check Clock Check Clock Check Clock	Platform	Warning	Latch	All	The real time clock had detected loss of its oscillator at some time in the past. Check / replace battery? This diagnostic can be effectively cleared only by writing a new value to the chiller's time clock using the TechView™ or DynaView™ "set chiller time" functions.	Remote
Chilled Water Flow (Entering Water Temp) Chilled Water Flow (Entering Water Temp) Chilled Wtr Flow (Ent Temp)	Chiller	Immediate	Latching	Any Ckt(s) Energized [No Ckt(s) Energized]	The entering evaporator water temp fell below the leaving evaporator water temperature by more than 3°F for 100°F-sec while at least one compressor was running.	Remote
Circuit Pumpdown Terminated Circuit Pumpdown Terminated Circuit Pumpdown Terminated	Circuit	Warning	Latching	Operational/ Service Pumpdown [All Except Operational and Service Pumpdown]	Operational Pumpdown or Service Pumpdown procedure did not terminate normally by reaching the termination pressure within the allotted time.	Remote
Compressor Fault Compressor Fault Compressor Fault	Cprsr	Immediate	NonLatch	All	The compressor fault switch input is open.	Local
Compressor Fault Lockout Compressor Fault Lockout Compressor Fault Lockout	Cprsr	Immediate	Latch	All	The compressor fault switch input remained open for more than 35 minutes. Five compressor fault diagnostics have occurred within the last 210 minutes.	Local
Emergency Stop Emergency Stop Emergency Stop	Chiller	Immediate	Latch	All	Emergency Stop input is open.	Local
Evaporator Pump 1 Starts/Hours Modified Evaporator Pump 1 Starts/Hours Modified Evap Pmp Starts/Hrs Modified	Chiller	Warning	NonLatch	All	A counter for evaporator pump 1 starts or hours has been modified by TechView. This diagnostic is immediately and automatically cleared and thus can only be seen in the historic diagnostic list.	NA
Evaporator Pump 2 Starts/Hours Modified Evaporator Pump 2 Starts/Hours Modified Evap Pmp Starts/Hrs Modified	Chiller	Warning	NonLatch	All	A counter for evaporator pump 2 starts or hours has been modified by TechView. This diagnostic is immediately and automatically cleared and thus can only be seen in the historic diagnostic list.	NA
Evaporator Water Flow Lost Evaporator Water Flow Lost Evap Water Flow Lost	Chiller	Immediate and Special Action	NonLatch	All	After the pump request was activated, water flow was established and then lost. Special action is to keep the evap pump request active in a diagnostic override mode.	Remote
Evaporator Water Flow Lost – Pump 1 Evaporator Water Flow Lost – Pump 1 Evap Water Flow Lost	Chiller	Warning and Special Action	NonLatch	All	For dual evaporator pump configurations only. Evaporator Water Flow Lost diagnostic occurred while Pump 1 was the selected pump.	Remote
Evaporator Water Flow Lost – Pump 2 Evaporator Water Flow Lost – Pump 2 Evap Water Flow Lost	Chiller	Warning and Special Action	NonLatch	All	For dual evaporator pump configurations only. Evaporator Water Flow Lost diagnostic occurred while Pump 2 was the selected pump.	Remote

Table 84. Main processor diagnostics (continued)

Evaporator Water Flow Lost Lockout Evaporator Water Flow Lost Lockout Evap Water Flow Lost Lockout	Chiller	Immediate	Latch	All	Four (4) water flow loss events occurred in a moving 4 day time window. Corrective action is needed to identify and eliminate the cause.	Local
Evaporator Water Flow Overdue Evaporator Water Flow Overdue Evap Water Flow Overdue	Chiller	Immediate and Special Action	NonLatch	All	After the pump request was activated, the evaporator water flow overdue wait time elapsed before water flow was established. Special action is to keep the evap pump request active in a diagnostic override mode.	Remote
Evaporator Water Flow Overdue – Pump 1 Evaporator Water Flow Overdue – Pump 1 Evap Water Flow Overdue	Chiller	Warning and Special Action	NonLatch	All	For dual evaporator pump configurations only. Evaporator Water Flow Overdue diagnostic occurred while Pump 1 was the selected pump.	Remote
Evaporator Water Flow Overdue – Pump 2 Evaporator Water Flow Overdue – Pump 2 Evap Water Flow Overdue	Chiller	Warning and Special Action	NonLatch	All	For dual evaporator pump configurations only. Evaporator Water Flow Overdue diagnostic occurred while Pump 2 was the selected pump.	Remote
Evaporator Water Flow Too Low Evaporator Water Flow Too Low Evap Water Flow Too Low	Chiller	Immediate	Latch	Cooling Mode [Not Cooling Mode]	Refrigerant side to water side heat balance indicates that water flow has dropped below allowable manufacturer limits.	Local
External Chilled/Hot Water Setpoint External Chilled/Hot Water Setpoint Ext Chilled/Hot Water Setpt	Chiller	Warning	NonLatch	All	a. Function Not “Enabled”: no diagnostics. B. “Enabled ”: Out-Of-Range Low or Hi or bad LLID, set diagnostic, default CWS/HWS to next level of priority (e.g. Front Panel SetPoint). This Warning diagnostic will automatically reset if the input returns to the normal range.	Remote
External Demand Limit Setpoint External Demand Limit Setpoint External Demand Limit Setpt	Chiller	Warning	NonLatch	All	a. Function Not “Enabled”: no diagnostics. B. “Enabled ”: Out-Of-Range Low or Hi or bad LLID, set diagnostic, default DLS to next level of priority (e.g. Front Panel SetPoint). This Warning diagnostic will automatically reset if the input returns to the normal range.	Remote
Fan Fault Fan Fault Fan Fault	Circuit	Warning	Latch	All	The fan deck is indicating a fault.	Local
Fan Inverter Fault Fan Inverter Fault Fan Inverter Fault	Circuit	Warning	NonLatch	Ckt Energized [Ckt Not Energized] All	The fan inverter fault input is ignored for the first 5 seconds of start up to allow variable speed drives to power up.	Local
Fault Detected: Evaporator Water Pump 1 Fault Detected: Evaporator Water Pump 1 Fault: Evap Water Pump	Chiller	Normal Immediate or Warning and Special Action	NonLatch	All	For systems with no evaporator pump, a single evaporator pump, or a single inverter driving dual evaporator pumps, an immediate shutdown shall be performed. For multiple pump systems, detection of a pump fault will generally cause pump control to switch to the redundant pump. For single inverter, dual pump configuration, switching to the redundant pump can only happen after the fault is cleared. For systems with no evaporator pump or a single evaporator pump, a normal shutdown shall be performed. For multiple pump systems, detection of a pump fault will generally cause pump control to switch to the redundant pump.	Remote

Diagnostics

Table 84. Main processor diagnostics (continued)

<p>Fault Detected: Evaporator Water Pump 2 Fault Detected: Evaporator Water Pump 2 Fault: Evap Water Pump</p>	Chiller	Normal Immediate or Warning and Special Action	NonLatch	All	<p>For systems with no evaporator pump, a single evaporator pump, or a single inverter driving dual evaporator pumps, an immediate shutdown shall be performed. For multiple pump systems, detection of a pump fault will generally cause pump control to switch to the redundant pump. For single inverter, dual pump configuration, switching to the redundant pump can only happen after the fault is cleared. For systems with no evaporator pump or a single evaporator pump, a normal shutdown shall be performed. For multiple pump systems, detection of a pump fault will generally cause pump control to switch to the redundant pump.</p>	Remote
<p>High Compressor Pressure Differential High Compressor Pressure Differential High Cprsr Press Diff</p>	Circuit	Immediate	Latch	Ckt Energized [Ckt Not Energized or Operational Pumpdown]	Compressor involute pressure differential exceeded allowable limits.	Local
<p>High Discharge Refrigerant Pressure High Discharge Refrigerant Pressure High Discharge Rfqt Press</p>	Circuit	Immediate	Latch	All	Discharge pressure exceeded the high pressure cutout setpoint + 100 kPa. Likely cause: failed or incorrectly set high pressure cutout switch. Prevents release of refrigerant through relief valve.	Local
<p>High Discharge Temperature High Discharge Temperature High Discharge Temperature</p>	Circuit	Immediate	NonLatch	Ckt Energized [Ckt Not Energized]	The discharge temperature exceeded the limits for the compressor.	Local
<p>High Discharge Temperature Lockout High Discharge Temperature Lockout High Discharge Temp Lockout</p>	Circuit	Immediate	Latch	All	5 high discharge temperature diagnostics occurred over 210 minutes.	
<p>High Evaporator Water Temperature High Evaporator Water Temperature High Evap Water Temperature</p>	Chiller	Info and Special Action	NonLatch	<p>Only effective if either</p> <ol style="list-style-type: none"> 1) Evaporator Water Flow Overdue, 2) Evaporator Water Flow Lost, 3) Low Evap Water Temp: Unit Off, diagnostic is active. 	<p>The leaving water temperature exceeded the high evap water temp setting (TV service menu settable– default 55.0°C (131°F)) for 15 continuous seconds. The evaporator water pump relay will be de-energized to stop the pump, but only if it is running due to one of the diagnostics listed on the left. The diagnostic will auto reset and the pump will return to normal control when the temperature falls 2.778°C (5°F) below the trip setting. The primary purpose is to stop the evaporator water pump and its associated pump heat from causing excessive water-side temperatures and water-side pressures when the unit is not running but the evap pump is on due to either Evaporator Water Flow Overdue, Evaporator Water Flow Lost, or Low Evap Water Temp – Unit Off diagnostics. This diagnostic will not auto clear solely due to the clearing of the enabling diagnostic.</p> <p>*at unit installation, especially reversible units, high evap water temp setting will need to be written. The value should be approximately 65.556°C (150°F) for heat pumps</p>	Remote
<p>High Pressure Cutout High Pressure Cutout High Pressure Cutout</p>	Circuit	Immediate	Latch	All	The high pressure cutout switch recognized a high pressure.	Local

Table 84. Main processor diagnostics (continued)

<p>High Suction Refrigerant Pressure High Suction Refrigerant Pressure High Suction Rfqt Press</p>	Chiller	Immediate	NonLatch	All	<p>Any circuit's suction pressure has risen above 95% of the high pressure cutout setting. The evaporator water pump relay will be de-energized to stop the pump regardless of why the pump is running. The diagnostic will auto reset and the pump will return to normal control when all circuits' suction pressures fall below 85% of the high pressure cutout setting.</p> <p>The primary purpose is to stop the evaporator water pump and its associated pump heat from causing refrigerant side pressures close to the relief valve setting when the chiller is not running, such as could occur with Evaporator Water Flow Overdue, Evaporator Water Flow Lost, or Low Evap Water Temp – Unit Off diagnostics. This condition is unlikely unless a discharge isolation valve is installed and closed.</p>	Remote
<p>Inverted Water Temp (Heating) Inverted Water Temp (Heating) Inverted Wtr Temp (Heating)</p>	Chiller	Immediate	Latching	Unit energized and all ckts' reversing valves in heating direction [Unit de-energized or any ckt's reversing valve in cooling direction]	The leaving evaporator water temp fell below the entering evaporator water temperature by more than 3°F for 100°F-sec. There is a 60 second ignore time after the condition to enable the diagnostic is met. During the ignore time, the temperature error is not integrated.	Remote
<p>LCI-C Software Mismatch: Use BAS Tool LCI-C Software Mismatch: Use BAS Tool LCI-C Software: Use BAS Tool</p>	Chiller	Warning	NonLatch	All	LCI-C Neuron software and LCI-C IPC3 software do not match. Load new LCI-C Neuron software using LonTalk® service tool.	Remote
<p>Loss of Charge Loss of Charge Loss of Charge</p>	Circuit	Immediate	Latch	Ckt Energized [Ckt Not Energized]	This feature is active on cooling-only units, not on heat pumps (even during cooling mode). The circuit must have EXV superheat control. See algorithm specification for details.	Local
<p>Low Differential Refrigerant Pressure Low Differential Refrigerant Pressure Low Differential Rfqt Press</p>	Circuit	Normal	Latch	Ckt Energized [Ckt Not Energized]	The system differential pressure for the respective circuit was below 90 psid for more than 4000 psid-sec, with a 2.5 minute ignore time from the start of the circuit.	Local
<p>Low Discharge Saturated Temperature Low Discharge Saturated Temperature Low Discharge Sat Temp</p>	Circuit	Normal	Latch	Ckt Energized [Ckt Not Energized]	The discharge saturated temperature for the respective circuit was below 20 °C for more than 3750 °C-sec, with a 10 minute ignore time from the start of the circuit. Integration starts after the ignore time is completed.	Local
<p>Low Evap Leaving Water Temp: Unit Off Low Evap Leaving Water Temp: Unit Off Low Evap Leav Wtr Temp: Off</p>	Chiller or Circuit	Warning and Special Action	NonLatch	Unit in Stop Mode, or in Auto Mode and No Ckt(s) Energized [Any Ckt Energized]	<p>The leaving chilled water temperature fell below the leaving water temp cutout setting for 30 degree F seconds while the Chiller is in the Stop mode, or in Auto mode with no compressors running. Energize Evap Water pump Relay until diagnostic auto resets, then return to normal evap pump control. Automatic reset occurs when the temp rises 2°F above the cutout setting for 30 minutes. When this diagnostic is active AND Leaving Water Temperature sensor diagnostic (loss of comm or out of range) the Evap Water pump relay shall be de-energized.</p> <p>If evaporator protection temperature sensors are installed, the effect is on the appropriate circuit. Else, the effect is on the chiller.</p>	Remote

Diagnostics

Table 84. Main processor diagnostics (continued)

<p>Low Evap Leaving Water Temp: Unit On Low Evap Leaving Water Temp: Unit On Low Evap Leav Wtr Temp: On</p>	Chiller or Circuit	Immediate and Special Action	NonLatch	Any Ckt[s] Energized [No Ckt(s) Energizd]	<p>The chilled water temp. fell below the cutout setpoint for 30 degree F Seconds while a compressor was running. Automatic reset occurs when the temperature rises 2 °F above the cutout setting for 2 minutes. This diagnostic shall not de-energize the Evaporator Water Pump Output. If this diagnostic is active the Low Evap Leaving Water Temp: Unit Off diagnostic shall be suppressed.</p> <p>If evaporator protection temperature sensors are installed, the effect is on the appropriate circuit. Else, the effect is on the chiller.</p>	Remote
<p>Low Pressure Cutout Low Pressure Cutout Low Pressure Cutout</p>	Circuit	Immediate	Latch	All	<p>The suction refrigerant pressure fell below the low pressure cutout trip point.</p>	Local
<p>Low Refrigerant Temperature Low Refrigerant Temperature Low Refrigerant Temperature</p>	Circuit	Immediate	Latch	Circuit Energized [Service Pumpdown, Operational Pumpdown]	<p>The suction saturated refrigerant temperature dropped below the Low Refrigerant Temperature Cutout Setpoint for 16.67°C-seconds (30°F-seconds).</p>	Local
<p>Low Suction Superheat Low Suction Superheat Low Suction Superheat</p>	Circuit	Immediate	Latch	Ckt Energized [Ckt Not Energized]	<p>Measured suction superheat stays below 2.22 °C for one continuous minute, with a 1 minute ignore time from the start of the circuit.</p> <p>Suction Superheat = suction temp – sat. suction temp.</p>	Local
<p>MP: Could not Store Starts and Hours MP: Could not Store Starts and Hours MP: Starts and Hours Failure</p>	Platform	Warning	Latch	All	<p>MP has determined there was an error with the previous power down store. Starts and Hours may have been lost for the last 24 hours.</p>	Remote
<p>MP: Non-Volatile Block Test Error MP: Non-Volatile Block Test Error MP: NV Block Test Error</p>	Platform	Warning	Latch	All	<p>MP has determined there was an error with a block in the Non-Volatile memory. Check settings.</p>	
<p>MP: Non-Volatile Memory Reformatted MP: Non-Volatile Memory Reformatted MP: NV Memory Reformatted</p>	Platform	Warning	Latch	All	<p>MP has determined there was an error in a sector of the Non-Volatile memory and it was reformatted. Check settings.</p>	Remote
<p>MP: Reset Has Occurred MP: Reset Has Occurred MP: Reset Has Occurred</p>	Chiller	Warning	NonLatch	All	<p>The main processor has successfully come out of a reset and built its application. A reset may have been due to a power up, installing new software or configuration. This diagnostic is immediately and automatically cleared and thus can only be seen in the historic diagnostic list.</p>	NA
<p>No Partial Heat Recovery No Partial Heat Recovery No Partial Heat Recovery</p>	Circuit	Warning	NonLatch	Ckt Energized [Ckt Not Energized]	<p>PHR entering water temperature is greater than the discharge temperature by 1.11°C for 30 continuous minutes.</p>	
<p>No Total Heat Recovery No Total Heat Recovery No Total Heat Recovery</p>	Heat Recovery	Normal Warning	NonLatch	Unit energized and THR control enabled [Unit de-energized or THR disabled]	<p>This diagnostic is only effective if all the following requirements are met: 1) Unit is running. 2) THR Control is enabled. 3) THR entering water temperature is less than 4°C, or discharge temperature integral is greater than Discharge Temperature Integral Limit in all the energized circuits.</p> <p>It shall be de-activated when any one of the following requirement is met: 1) THR entering water temperature is greater than 5°C., and the discharge saturated temperature is greater than minimum discharge saturated temperature in at least one energized circuit, see Total Heat Recovery Control Algorithm specification for details. 2) THR entering water temperature is invalid (comm loss or sensor diagnostic). 3) Total Heat Recovery Control disabled. 4) No compressor energized.</p>	Remote

Table 84. Main processor diagnostics (continued)

Phase Protection Fault Phase Protection Fault Phase Protection Fault	Chiller	Immediate	NonLatch	All	Phase protection module recognized a phase loss or phase reversal of the line power. Reset automatically after module recognizes good power for 30 continuous seconds.	Local
Power Factor Correction Fault Power Factor Correction Fault Pwr Factor Correction Fault	Chiller	Warning	Latch	All	Power Factor Correction module has signaled a fault condition.	Remote
Software Error 1001: Call Trane Service Software Error 1001: Call Trane Service Software Error 1001	All functions	Immediate	Latch	All	A software monitor has detected a condition in which there was a continuous 1 minute period of compressor operation, with no Evaporator water flow. The presence of this software error message suggests an internal software problem has been detected. The events that led up to this failure, if known, should be recorded and transmitted to Trane Controls Engineering.	Local
Software Error 1002: Call Trane Service Software Error 1002: Call Trane Service Software Error 1002	All functions	Immediate	Latch	All	A software monitor has detected a condition in which there was a continuous 1 minute period of compressor operation, with a misaligned state machine. Reported if state chart misalignment occurred inferred from the Capacity Control, Circuit, or Compressor State Machines being in <i>Stopped state</i> or <i>Inactive state</i> while a compressor was operating and this condition existed for at least 1 minute. The presence of this software error message suggests an internal software problem has been detected. The events that led up to this failure, if known, should be recorded and transmitted to Trane Controls Engineering.	Local
Software Error 1003: Call Trane Service Software Error 1003: Call Trane Service Software Error 1003	All functions	Immediate	Latch	All	A software monitor has detected a condition in which there was a continuous 1 minute period of compressor operation, with a misaligned state machine. Reported if state chart misalignment occurred inferred from the Capacity Control, Circuit, or Compressor State Machines remaining in the Stopping state for more than 4 minutes with operating compressors. The presence of this software error message suggests an internal software problem has been detected. The events that led up to this failure, if known, should be recorded and transmitted to Trane Controls Engineering.	Local
Starts/Hours Modified Starts/Hours Modified Starts/Hours Modified	Cprsr	Warning	NonLatch	All	A counter for compressor starts or hours has been modified by TechView. This diagnostic is immediately and automatically cleared and thus can only be seen in the historic diagnostic list.	NA
Suction Temperature Too High Suction Temperature Too High Suction Temp Too High	Circuit	Immediate	Latch	Ckt Energized [Ckt Not Energized]	The suction temperature measurement is larger than the entering temperature by more than a threshold value for 5 continuous minutes. The threshold value is 3°C (5.4°F) for cooling-only units, and 5°C (9°F) for heat pumps. The entering temperature is the evaporator entering water temperature when the reversing valve is in the cooling direction, and the ambient air temperature when the reversing valve is in the heating direction. There is an ignore time of 2 minutes following circuit startup. The trip criteria is not evaluated (and time above the threshold is not counted) until the ignore time passes.	Local



Diagnostics

Table 84. Main processor diagnostics (continued)

Very Low Suction Pressure – Circuit 1 Very Low Suction Pressure – Circuit 1 Very Low Suct Press – Ckt 1	Chiller	Immediate	Latch	All [circuit in manual lockout]	The circuit's suction pressure dropped below (Low Pressure Cutout Setpoint (kPa absolute) * 0.5) regardless of whether or not compressors are running on that circuit. This diagnostic was created to prevent compressor failures due to cross-binding by forcing an entire chiller shutdown. If a given circuit is locked out, the suction pressure transducer associated with it will be excluded from causing this diagnostic.	Local
Very Low Suction Pressure – Circuit 2 Very Low Suction Pressure – Circuit 2 Very Low Suct Press – Ckt 2	Chiller	Immediate	Latch	All [circuit in manual lockout]	The circuit's suction pressure dropped below (Low Pressure Cutout Setpoint (kPa absolute) * 0.5) regardless of whether or not compressors are running on that circuit. This diagnostic was created to prevent compressor failures due to crossbinding by forcing an entire chiller shutdown. If a given circuit is locked out, the suction pressure transducer associated with it will be excluded from causing this diagnostic.	Local

Sensor Failure Diagnostics

Notes:

1. The following sensor failure diagnostics will not occur unless that input or output is required to be present by the particular configuration and installed options for the unit.
2. Sensor diagnostics are named by the Functional Name of the input or output that is no longer sending a valid

value to the Main Processor, indicating a sensor failure. Some LLIDs may have more than one functional output associated with it. Refer to the unit's wiring diagrams to relate the occurrence of such sensor failure diagnostics back to the physical LLID boards that they have been assigned to (bound).

Table 85. Sensor failure diagnostics

Diagnostic Name	Affects	Severity	Persist-ence	Active Modes [Inactive Modes]	Criteria	Reset Level
Discharge Pressure Transducer Discharge Pressure Transducer Discharge Pressure Xdcr	Circuit	Immediate	Latch	All	Bad Sensor or LLID	Remote
Discharge Temperature Sensor Discharge Temperature Sensor Discharge Temperature Sensor	Circuit	Immediate	Latch	All	Bad Sensor or LLID	Remote
Evaporator Entering Water Temp Sensor Evaporator Entering Water Temp Sensor Evap Ent Water Temp Sensor	Chiller	Normal	Latch	All	Bad Sensor or LLID.	Remote
Evaporator Leaving Water Temp Sensor Evaporator Leaving Water Temp Sensor Evap Leav Water Temp Sensor	Chiller	Normal	Latch	All	Bad Sensor or LLID	Remote
Heat Recovery Entering Water Temp Sensor Heat Recovery Entering Water Temp Sensor HR Entering Wtr Temp Sensor	Heat Recovery	Warning or Normal	Latch	All	Bad Sensor or LLID. Warning for Partial Heat Recovery. Normal shutdown for Total Heat Recovery.	Remote
Heat Recovery Leaving Water Temp Sensor Heat Recovery Leaving Water Temp Sensor HR Leaving Wtr Temp Sensor	Heat Recovery	Warning	Latch	All	Bad Sensor or LLID	Remote
Outdoor Air Temp Sensor Outdoor Air Temp Sensor Outdoor Air Temp Sensor	Chiller	Normal	Latch	All	Bad Sensor or LLID.	Remote
Suction Pressure Transducer Suction Pressure Transducer Suction Pressure Xdcr	Circuit	Immediate	Latch	All	Bad Sensor or LLID	Remote
Suction Temperature Sensor Suction Temperature Sensor Suction Temperature Sensor	Circuit	Immediate	Latch	All	Bad Sensor or LLID	Remote

Communication Diagnostics

Note: The following communication loss diagnostics will not occur unless that input or output is required to be present by the particular configuration and installed options for the chiller. 2. Communication diagnostics (with the exception of "Excessive Loss of Comm" are named by the Functional Name of the input or output that is no longer being heard from by the Main Processor. Many LLIDs, such as the Quad Relay LLID, have more than one

functional output associated with it. A comm loss with such a multiple function board, will generate multiple diagnostics. Refer to the Chiller's wiring diagrams to relate the occurrence of multiple communication diagnostics back to the physical llid boards that they have been assigned to (bound).

Table 86. Communication diagnostics

Diagnostic Name	Affects	Severity	Persistence	Active Modes [Inactive Modes]	Criteria	Reset Level
Comm Loss: Anti-Freeze Heater Relay <i>Comm Loss: Anti-Freeze Heater Relay</i> Comm: Anti-Freeze Heater Rly	Chiller	Warning and Special Action	Latch	All	Continual loss of communication between the MP and the Functional ID has occurred for a 35-40 second period.	Remote
Comm Loss: Auxiliary Setpoint Command <i>Comm Loss: Auxiliary Setpoint Command</i> Comm: Auxiliary Setpt Cmd	Chiller	Warning and Special Action	Latch	All	Continual loss of communication between the MP and the Functional ID has occurred for a 35-40 second period. Chiller shall discontinue use of the Auxiliary Setpoint and revert to the Chilled Water Setpoint based on setpoint arbitration	Remote
Comm Loss: Compressor Fault Input <i>Comm Loss: Compressor Fault Input</i> Comm: Compressor Fault Input	Cprsr	Immediate	Latch	All	Continual loss of communication between the MP and the Functional ID has occurred for a 35-40 second period.	Remote
Comm Loss: Compressor Run Command <i>Comm Loss: Compressor Run Command</i> Comm: Cprsr Run Command	Cprsr	Immediate	Latch	All	Continual loss of communication between the MP and the Functional ID has occurred for a 35-40 second period.	Remote
Comm Loss: Cooling EXV <i>Comm Loss: Cooling EXV</i> Comm: Cooling EXV	Circuit	Immediate	Latch	All	Continual loss of communication between the MP and the Functional ID has occurred for a 35-40 second period.	Remote
Comm Loss: Discharge Pressure Transducer <i>Comm Loss: Discharge Pressure Transducer</i> Comm: Discharge Press Xdcr	Circuit	Immediate	Latch	All	Continual loss of communication between the MP and the Functional ID has occurred for a 35-40 second period.	Remote
Comm Loss: Discharge Temperature Sensor <i>Comm Loss: Discharge Temperature Sensor</i> Comm: Discharge Temp Sensor	Circuit	Immediate	Latch	All	Continual loss of communication between the MP and the Functional ID has occurred for a 35-40 second period.	Remote
Comm Loss: Electronic Expansion Valve <i>Comm Loss: Electronic Expansion Valve</i> Comm: EXV	Circuit	Immediate	Latch	All	Continual loss of communication between the MP and the Functional ID has occurred for a 35-40 second period.	Remote
Comm Loss: Emergency Stop <i>Comm Loss: Emergency Stop</i> Comm: Emergency Stop	Chiller	Normal	Latch	All	Continual loss of communication between the MP and the Functional ID has occurred for a 35-40 second period.	Remote
Comm Loss: Evap Entering Water Temp <i>Comm Loss: Evap Entering Water Temp</i> Comm: Evap Ent Water Temp	Chiller	Normal	Latch	All	Continual loss of communication between the MP and the Functional ID has occurred for a 35-40 second period.	Remote
Comm Loss: Evap Leaving Water Temp <i>Comm Loss: Evap Leaving Water Temp</i> Comm: Evap Leav Water Temp	Chiller	Normal	Latch	All	Continual loss of communication between the MP and the Functional ID has occurred for a 35-40 second period.	Remote
Comm Loss: Evap Pump Inverter 1 Fault Input <i>Comm Loss: Evap Pump Inv 1 Fault Input</i> Comm: Evap Pmp Inv 1 Flt Inp	Chiller	Normal	Latch	All	Continual loss of communication between the MP and the Functional ID has occurred for a 35-40 second period.	Remote
Comm Loss: Evap Pump Inverter 1 Frequency Feedback <i>Comm Loss: Evap Pump Inv 1 Freq Feedback</i> Comm: Evap Pmp Inv 1 Freq	Chiller	Normal	Latch	All	Continual loss of communication between the MP and the Functional ID has occurred for a 35-40 second period.	Remote
Comm Loss: Evap Pump Inverter 1 Run Command <i>Comm Loss: Evap Pump Inverter 1 Run Cmd</i> Comm: Evap Pmp Inv 1 Run Cmd	Chiller	Normal	Latch	All	Continual loss of communication between the MP and the Functional ID has occurred for a 35-40 second period.	Remote

Table 86. Communication diagnostics (continued)

Comm Loss: Evaporator Pump 1 Fault Input <i>Comm Loss: Evaporator Pump 1 Fault Input</i> Comm: Evap Pump Fault Input	Chiller	Normal	Latch	All	Continual loss of communication between the MP and the Functional ID has occurred for a 35-40 second period.	Remote
Comm Loss: Evaporator Pump 2 Fault Input <i>Comm Loss: Evaporator Pump 2 Fault Input</i> Comm: Evap Pump Fault Input	Chiller	Normal	Latch	All	Continual loss of communication between the MP and the Functional ID has occurred for a 35-40 second period.	Remote
Comm Loss: Evaporator Water Flow Switch <i>Comm Loss: Evaporator Water Flow Switch</i> Comm: Evap Water Flow Sw	Chiller	Immediate	Latch	All	Continual loss of communication between the MP and the Functional ID has occurred for a 35-40 second period.	Remote
Comm Loss: Evaporator Water Pump 1 Relay <i>Comm Loss: Evaporator Water Pump 1 Relay</i> Comm: Evap Water Pump Relay	Chiller	Normal	Latch	All	Continual loss of communication between the MP and the Functional ID has occurred for a 35-40 second period.	Remote
Comm Loss: Evaporator Water Pump 2 Relay <i>Comm Loss: Evaporator Water Pump 2 Relay</i> Comm: Evap Water Pump Relay	Chiller	Normal	Latch	All	Continual loss of communication between the MP and the Functional ID has occurred for a 35-40 second period.	Remote
Comm Loss: Ext Chilled/Hot Wtr Setpoint <i>Comm Loss: Ext Chilled/Hot Wtr Setpoint</i> Comm: Ext Chil/Hot Wtr Setpt	Chiller	Warning and Special Action	Latch	All	Continual loss of communication between the MP and the Functional ID has occurred for a 35-40 second period. Chiller shall discontinue use of the External Chilled/Hot Water Setpoint source and revert to the next higher priority for setpoint arbitration	Remote
Comm Loss: Ext Demand Limit Setpoint <i>Comm Loss: Ext Demand Limit Setpoint</i> Comm: Ext Demand Limit Setpt	Chiller	Warning and Special Action	Latch	All	Continual loss of communication between the MP and the Functional ID has occurred for a 35-40 second period. Chiller shall discontinue use of the External Demand Limit Setpoint source and revert to the next higher priority for setpoint arbitration	Remote
Comm Loss: External Auto/Stop <i>Comm Loss: External Auto/Stop</i> Comm: External Auto/Stop	Chiller	Normal	Latch	All	Continual loss of communication between the MP and the Functional ID has occurred for a 35-40 second period.	Remote
Comm Loss: External Heat Recovery Input <i>Comm Loss: External Heat Recovery Input</i> Comm: Ext Heat Recovery Inp	Heat Recovery	Warning and Special Action	Latch	All	Continual loss of communication between the MP and the Functional ID has occurred for a 35-40 second period. External input is excluded from arbitration logic per standard arbitration rules.	Remote
Comm Loss: External Ice Building Control Input <i>Comm Loss: Ext Ice Building Ctrl Input</i> Comm: Ext Ice Building Ctrl	Chiller	Warning	Latch	All	Continual loss of communication between the MP and the Functional ID has occurred for a 35-40 second period. Chiller shall revert to normal (non-ice building) mode regardless of last state.	Remote
Comm Loss: External Night Noise Setback Input <i>Comm Loss: Ext Night Noise Setback Input</i> Comm: Ext Night Noise Inp	Chiller	Warning and Special Action	Latch	All	Continual loss of communication between the MP and the Functional ID has occurred for a 35-40 second period. External input is excluded from arbitration logic per standard arbitration rules.	Remote
Comm Loss: Fan Control Relays <i>Comm Loss: Fan Control Relays</i> Comm: Fan Control Relays	Circuit	Immediate	Latch	All	Continual loss of communication between the MP and the Functional ID has occurred for a 35-40 second period.	Remote
Comm Loss: Fan Fault <i>Comm Loss: Fan Fault</i> Comm: Fan Fault	Circuit	Warning	Latch	All	Continual loss of communication between the MP and the Functional ID has occurred for a 35-40 second period.	Remote
Comm Loss: Fan Inverter Fault <i>Comm Loss: Fan Inverter Fault</i> Comm: Fan Inverter Fault	Circuit	Warning and Special Action	Latch	All	Continual loss of communication between the MP and the Functional ID has occurred for a 35-40 second period. Revert to fixed-speed fan algorithm using remaining fans.	Remote
Comm Loss: Fan Inverter Speed Command <i>Comm Loss: Fan Inverter Speed Command</i> Comm: Fan Inverter Speed Cmd	Circuit	Warning and Special Action	Non Latch	All	Continual loss of communication between the MP and the Functional ID has occurred for a 35-40 second period. Revert to fixed-speed fan algorithm using remaining fans.	Remote
Comm Loss: Heat Recovery Entering Water Temperature Sensor <i>Comm Loss: HR Entering Water Temperature</i> Comm: HR Entering Water Temp	Heat Recovery	Warning or Normal	Latch	All	Continual loss of communication between the MP and the Functional ID has occurred for a 35-40 second period. Warning for Partial Heat Recovery. Normal shutdown for Total Heat Recovery.	Remote
Comm Loss: Heat Recovery Leaving Water Temperature Sensor <i>Comm Loss: HR Leaving Water Temperature</i> Comm: HR Leaving Water Temp	Heat Recovery	Warning	Latch	All	Continual loss of communication between the MP and the Functional ID has occurred for a 35-40 second period.	Remote

Table 86. Communication diagnostics (continued)

Comm Loss: Heat Recovery Three Way Valve <i>Comm Loss: Heat Recovery Three Way Valve</i> Comm: HR Three Way Valve	Heat Recovery	Normal	Latch	All	Continual loss of communication between the MP and the Functional ID has occurred for a 35-40 second period.	Remote
Comm Loss: Heat/Cool Switch <i>Comm Loss: Heat/Cool Switch</i> Comm: Heat/Cool Switch	Chiller	Normal	Latch	All	Continual loss of communication between the MP and the Functional ID has occurred for a 35-40 second period.	Remote
Comm Loss: Heating EXV <i>Comm Loss: Heating EXV</i> Comm: Heating EXV	Circuit	Immediate	Latch	All	Continual loss of communication between the MP and the Functional ID has occurred for a 35-40 second period.	Remote
Comm Loss: High Pressure Cutout Switch <i>Comm Loss: High Pressure Cutout Switch</i> Comm: High Press Cutout Sw	Circuit	Immediate	Latch	All	Continual loss of communication between the MP and the Functional ID has occurred for a 35-40 second period.	Remote
Comm Loss: Local BAS Interface <i>Comm Loss: Local BAS Interface</i> Comm: Local BAS Interface	Chiller	Warning and Special Action	Non Latch	All	Continual loss of communication between the MP and the Functional ID has occurred for a 35-40 second period. Use the last values sent from BAS.	Remote
Comm Loss: Night Noise Setback Relay <i>Comm Loss: Night Noise Setback Relay</i> Comm: Night Noise Setbk Rly	Chiller	Normal	Latch	All	Continual loss of communication between the MP and the Functional ID has occurred for a 35-40 second period.	Remote
Comm Loss: Op Status Programmable Relays <i>Comm Loss: Op Status Programmable Relays</i> Comm: Op Status Relays	Chiller	Warning	Latch	All	Continual loss of communication between the MP and the Functional ID has occurred for a 35-40 second period.	Remote
Comm Loss: Outdoor Air Temperature <i>Comm Loss: Outdoor Air Temperature</i> Comm: Outdoor Air Temp	Chiller	Normal	Latch	All	Continual loss of communication between the MP and the Functional ID has occurred for a 35-40 second period.	Remote
Comm Loss: Percent Capacity Output <i>Comm Loss: Percent Capacity Output</i> Comm: Percent Capacity Out	Chiller	Warning	Latch	All	Continual loss of communication between the MP and the Functional ID has occurred for a 35-40 second period.	Remote
Comm Loss: Phase Protection Fault Input <i>Comm Loss: Phase Protection Fault Input</i> Comm: Phase Protect Flt Inp	Chiller	Normal	Latch	All	Continual loss of communication between the MP and the Functional ID has occurred for a 35-40 second period.	Remote
Comm Loss: Power Factor Correction Fault Input <i>Comm Loss: Power Factor Correction Fault</i> Comm: Pwr Fac Correction Flt	Chiller	Warning	Latch	All	Continual loss of communication between the MP and the Functional ID has occurred for a 35-40 second period.	Remote
Comm Loss: Receiver Fill Valve Relay <i>Comm Loss: Receiver Fill Valve Relay</i> Comm: Receiver Fill Vlv Rly	Circuit	Normal	Latch	All	Continual loss of communication between the MP and the Functional ID has occurred for a 35-40 second period.	Remote
Comm Loss: Reversing Valve <i>Comm Loss: Reversing Valve</i> Comm: Reversing Valve	Circuit	Normal	Latch	All	Continual loss of communication between the MP and the Functional ID has occurred for a 35-40 sec period.	Remote
Comm Loss: Subcooler Shutoff Valve Relay <i>Comm Loss: Subcooler Shutoff Valve Relay</i> Comm: Subcooler Shut Vlv Rly	Circuit	Normal	Latch	All	Continual loss of communication between the MP and the Functional ID has occurred for a 35-40 sec period.	Remote
Comm Loss: Suction Pressure Transducer <i>Comm Loss: Suction Pressure Transducer</i> Comm: Suction Pressure Xdcr	Circuit	Immediate	Latch	All	Continual loss of communication between the MP and the Functional ID has occurred for a 35-40 second period.	Remote
Comm Loss: Suction Temperature <i>Comm Loss: Suction Temperature</i> Comm: Suction Temperature	Circuit	Immediate	Latch	All	Continual loss of communication between the MP and the Functional ID has occurred for a 35-40 second period.	Remote
Comm Loss: Supplemental Heat Relay 1 <i>Comm Loss: Supplemental Heat Relay 1</i> Comm: Supplmntl Heat Rly 1	Chiller	Warning	Latch	All	Continual loss of communication between the MP and the Functional ID for relay 1 has occurred for a 35-40 second period.	Remote
Comm Loss: Supplemental Heat Relay 2 <i>Comm Loss: Supplemental Heat Relay 2</i> Comm: Supplmntl Heat Rly 2	Chiller	Warning	Latch	All	Continual loss of communication between the MP and the Functional ID for relay 2 has occurred for a 35-40 second period.	Remote
Comm Loss: Supplemental Heat Relay 3 <i>Comm Loss: Supplemental Heat Relay 3</i> Comm: Supplmntl Heat Rly 3	Chiller	Warning	Latch	All	Continual loss of communication between the MP and the Functional ID for relay 3 has occurred for a 35-40 second period.	Remote
Comm Loss: Supplemental Heat Relay 4 <i>Comm Loss: Supplemental Heat Relay 4</i> Comm: Supplmntl Heat Rly 4	Chiller	Warning	Latch	All	Continual loss of communication between the MP and the Functional ID for relay 4 has occurred for a 35-40 second period.	Remote
Excessive Loss of Comm <i>Excessive Loss of Comm</i> Excessive Loss of Comm	Chiller	Immediate	Latch	All	Loss of comm with 10 or more LLIDs has been detected. Diagnostic will suppress callout of all subsequent comm loss diagnostics. Check power supply(s), power disconnects. Troubleshoot LLID bus in TechView.	Remote



Diagnostics

Main Processor- Boot Messages and Diagnostics

DynaView Display	Description/Troubleshooting
A Valid Configuration is Present	A valid configuration is present in the MP's nonvolatile memory. The configuration is a set of variables and settings that define the physical makeup of this particular chiller. These include: number/airflow./and type of fans, number/and size of compressors, special features, characteristics, and control options. // Temporary display of this screen is part of the normal power up sequence.
App Present. Running Selftest... Selftest Passed	An application has been detected in the Main Processor's nonvolatile memory and the boot code is proceeding to run a check on its entirety. 8 seconds later, the boot code had completed and passed the (CRC) test. // Temporary display of this screen is part of the normal power up sequence.
App Present. Running Selftest Err3: CRC Failure	An application has been detected in Main Processor's nonvolatile memory and the boot code is proceeding to run a check on its entirety. A few seconds later, the boot code had completed but failed the (CRC) test. //Connect a TechView Service Tool to the MP's serial port, provide chiller model number (configuration information) and download the configuration if prompted by TechView. Then proceed to download the most recent RTAC application or specific version as recommended by Technical Service. Note that this error display may also occur during the programming process, if the MP never had a valid application any time prior to the download. If problem persists, replace MP.
Boot Software Part Numbers: LS Flash --> 6200-0318-XX MS Flash --> 6200-0319-XX	The "boot code" is the portion of the code that is resident in all MPs regardless of what application code (if any) is loaded. Its main function is to run power up tests and provide a means for downloading application code via the MP's serial connection. The Part numbers for the code are displayed in the lower left hand corner of the DynaView during the early portion of the power up sequence and during special programming and converter modes. See below. // This is normal, but you should provide this information when contacting Technical Service about power up problems.
Converter Mode	A command was received from the Service Tool (Tech View) to stop the running application and run in the "converter mode". In this mode the MP acts as a simple gateway and allows the TechView service computer to talk to all the LLIDS on the IPC3 bus.
Err2: RAM Addr Test #1 Failure	There were RAM errors detected in RAM Address Test #1. //Recycle power, if error persists, replace MP.
Err2: RAM Addr Test #2 Failure	There were RAM errors detected in RAM Address Test #2. //Recycle power, if the error persists, replace MP.
Err2: RAM Pattern 1 Failure	There were RAM errors detected in RAM Test Pattern #1. // Recycle power, if the error persists, replace MP.
Err2: RAM Pattern 2 Failure	There were RAM errors detected in RAM Test Pattern #2. //Recycle power, if the error persists, replace MP.
Err4: UnHandled Interrupt Restart Timer: [3 sec countdown timer]	An unhandled interrupt has occurred while running the application code. This event will normally cause a safe shutdown of the entire chiller. Once the countdown timer reaches 0, the processor will reset, clear diagnostics, and attempt to restart the application and allow a normal restart of chiller as appropriate. // This condition might occur due to a severe electro-magnetic transient such as can be caused by a near lightening strike. Such events should be rare or isolated and if no damage results to the CH.530 control system, the Chiller will experience a shutdown and restart. If this occurs more persistently it may be due to an MP hardware problem. Try replacing the MP. If replacement of the MP proves ineffective, the problem may be a result of extremely high radiated or conducted EMI. Contact Technical Service. If this screen occurs immediately after a software download, attempt to reload both the configuration and the application. Failing this, contact Technical Service.
Err5: Operating System Error Restart Timer: [3 sec countdown timer]	An Operating System error has occurred while running the application code. This event will normally cause a safe shutdown of the entire chiller. Once the countdown timer reaches 0, the processor will reset, clear diagnostics, and attempt to restart the application and allow a normal restart of chiller as appropriate. // See Err 4 above
Err6: Watch Dog Timer Error Restart Timer: [3 sec countdown timer]	A Watch Dog Timer Error has occurred while running the application code. This event will normally cause a safe shutdown of the entire chiller. Once the countdown timer reaches 0, the processor will reset, clear diagnostics, and attempt to restart the application allowing a normal restart of chiller as appropriate.
Err7: Unknown Error Restart Timer: [3 sec countdown timer]	An unknown Error has occurred while running the application code. This event will normally cause a safe shutdown of the entire chiller. Once the countdown timer reaches 0, the processor will reset, clear diagnostics, and attempt to restart the application allowing a normal restart of chiller as appropriate
Err8: Held in Boot by User Key Press [3 sec countdown timer]	A touch was detected during boot indicating the user wanted to stay in boot mode. This mode can be used to recover from a fatal software error in the application code. Cycle power on the MP to clear this error if it was unintentional.
MP Application Memory CRC Error	App software inside the MP failed its own checksum test. Possible causes: application software in the MP is not complete – software download to the MP was not completed successfully - or MP hardware problem. Note: User should attempt to reprogram the MP if this diagnostic occurs.
MP: Invalid Configuration	MP has an invalid configuration based on the current software installed
No Application Present Please Load Application...	No Main Processor Application is present – There are no RAM Test Errors. // Connect a TechView Service Tool to the MP's serial port, provide chiller model number (configuration information) and download the configuration if prompted by TechView. Then proceed to download the most recent application or specific version as recommended by Technical Service.
Programming Mode	A command was received by the MP from the Tech View Service Tool and the MP is in the process of first erasing and then writing the program code to its internal Flash (nonvolatile) Memory. Note that if the MP never had a prior application already in memory, the error code "Err3"will be displayed instead of this, during the programming download process.



Unit Wiring

Table below provides a list of 20-130 ton CGAM electrical schematics, field wiring and connection diagrams. Complete unit wiring package is documented in CGAM-SVE01*-EN. A laminated wiring diagram kit is also shipped with each unit.

Drawing Number		Description	
2309-2075 Slant Frame Units	Sheet 1	Schematic Slant Frame Units	Table of Contents
	Sheet 2		Legend
	Sheet 3		Notes
	Sheet 4		Compressor Power Circuit 1
	Sheet 5		Blank
	Sheet 6		Fan Power Circuit 1
	Sheet 7		Fan Power Circuit 1
	Sheet 8		Blank
	Sheet 9		Blank
	Sheet 10		Pump Power/Control
	Sheet 11		Compressor Control
	Sheet 12		Fan Control, 2 & 3 Fan/Ckt Units
	Sheet 13		Blank
	Sheet 14		Common Control
	Sheet 15		CH530 Control
	Sheet 16		Freeze Protection
2309-2075 V Frame Units	Sheet 1	Schematic V Frame Units	Table of Contents
	Sheet 2		Legend
	Sheet 3		Notes
	Sheet 4		Compressor Power Circuit 1
	Sheet 5		Compressor Power Circuit 2
	Sheet 6		Fan Power Circuit 1
	Sheet 7		Fan Power Circuit 1
	Sheet 8		Fan Power Circuit 2
	Sheet 9		Fan Power Circuit 2
	Sheet 10		Pump Power/Control
	Sheet 11		Compressor Control
	Sheet 12		Fan Control, 2 & 3 Fan/Ckt Units
	Sheet 13		Blank
	Sheet 14		Common Control
	Sheet 15		CH530 Control
	Sheet 16		Freeze Protection
2309-2075 W Frame Units	Sheet 1	Schematic W Frame Units	Table of Contents
	Sheet 2		Legend
	Sheet 3		Notes
	Sheet 4		Compressor Power Circuit 1
	Sheet 5		Compressor Power Circuit 2
	Sheet 6		Fan Power Circuit 1
	Sheet 7		Fan Power Circuit 1
	Sheet 8		Fan Power Circuit 2
	Sheet 9		Fan Power Circuit 2
	Sheet 10		Pump Power/Control
	Sheet 11		Compressor Control
	Sheet 12		Fan Control, 2 & 3 Fan/Ckt Units
	Sheet 13		Fan Control, 4 & 5 Fan/Ckt Units
	Sheet 14		Common Control
	Sheet 15		CH530 Control
	Sheet 16		Freeze Protection
2309-2076	Sheet 1	Field Wiring	Diagram
	Sheet 2		Notes
5720-6468	Sheet 1	Diagram - Slant Frame	Component Location - Control Panel
	Sheet 2		
5720-6497		Assembly - Slant Frame	Device Location Sensor and CH530
5720-6469	Sheet 1, 2	Diagram - V frame	Component Location - Control Panel
5720-6498		Assembly - V Frame	Assembly - Device Location Sensor and CH530 - V frame
5720-6470	Sheet 1, 2	Diagram - W Frame	Component Location - Control Panel
5720-6499		Assembly - W Frame	Assembly - Device Location Sensor and CH530
5722-4410		Diagram - Slant, V, W	Component Location - VSD Pump Enclosure



Log and Check Sheet

The check sheet is included for use as appropriate, for installation completion verification before Trane start-up is scheduled, and for reference during the Trane start-up.

Where the check sheet also exists outside of this publication as standalone literature, the literature order number is also listed.

- CGAM Installation Completion Check Sheet and Request for Trane Service (CG-ADF001*-EN)



CGAM Air-Cooled Scroll Chiller Installation Completion Check Sheet and Request for Trane Service

Important: A copy of this completed form must be submitted to the Trane service agency that will be responsible for the start-up of the chiller. Start-up will NOT proceed unless applicable items listed in this form have been satisfactorily completed.

To:	Trane Service Office:
S.O. Number:	Serial Numbers:
Job/Project Name:	
Address:	
The following items are being installed and will be completed by:	

Important: Start-up must be performed by Trane or an agent of Trane specifically authorized to perform start-up of Trane® products. Contractor shall provide Trane (or an agent of Trane specifically authorized to perform start-up) with notice of the scheduled start-up at least two weeks prior to the scheduled start-up.

Important: It is required that heaters are energized for a minimum of 24 hours prior to start up. Therefore, chiller should have power for this amount of time before Trane Service arrives to do start-up.

Copyright

This document and the information in it are the property of Trane, and may not be used or reproduced in whole or in part without written permission. Trane reserves the right to revise this publication at any time, and to make changes to its content without obligation to notify any person of such revision or change.

Trademarks

All trademarks referenced in this document are the trademarks of their respective owners.

Revision History

- Updated check sheet template.

Check boxes if the task is complete or if the answer is "yes."

1. CGAM Chiller

- Installation meets foundation requirements.
- In place and piped.
- Isolation pads or neoprene pads installed (optional).

2. Piping

Chilled water piping connected to:

- Evaporator
- Heat recovery (if applicable)
- Air handling units
- Pumps (no piping to pump required if optional pump package is installed)
- Secondary flow proving device installed (recommended)
- Strainer installed and cleaned
- Verify chilled water inlet vents and chilled water outlet drains are closed.
- Water supply connected to filling system
- Does unit have freeze inhibitor? If unit has freeze inhibitor:
 - Verify type and concentration correct per unit submittal
 - Calculate and record freeze point of the solution: _____
- Systems filled
- Pumps run, air bled from system
- Strainer cleaned

Note: Do NOT remove strainer mesh to clean the system.

- Relief valve ventilation piping installed (if applicable)

Flow balancing valves installed on:

- Leaving chilled water
- Optional heat recovery (if applicable)

Gauges, thermometers, and air vents installed on:

- Both sides of evaporator
- Optional heat recovery (if applicable)

3. Wiring

- Wire size per submittal and NEC 310-16.
- Unit is properly grounded.
- Wiring connects are tight.
Note: Do NOT overtorque.
- Full power available, and within utilization range.
- Interconnecting wiring to control panel (as required)
- External interlocks (secondary proof of flow, pumps auxiliary, etc.)
- Chilled water pump connected and tested (not required if optional pump package is installed)
- Heat recovery condenser water pump (as applicable)
- 115 Vac power available for service tools
- All controls installed and connected

4. Testing

- Trace gas amounts of R-410A available for leak testing, if necessary

5. Refrigerant on job site, if unit shipped with nitrogen charge

- Dry nitrogen available for pressure testing

6. Systems can be operated under load conditions

Important: Start-up cannot be completed without ability to fully load the unit.

Important:

7. Heaters

- Verify that the compressor oil sump heaters are installed tightly around the compressor. Energize and verify heaters are operational using a temperature probe.
- If unit was factory charged (model number digit 20 = 1), **energize heaters for 24 hours prior to start up.**
Important: It is required that chiller heaters are energized for a minimum of 24 hours prior to start up. Therefore, chiller should have power for this amount of time before Trane Service arrives to do start-up.
- If unit has nitrogen charge (model number digit 20 = 2), contact Trane Service for unit charging prior to start-up.

8. Owner awareness

- Does the owner have a copy of the MSDS for refrigerant?



Note: Additional time required to properly complete the start-up and commissioning, due to any incompleteness of the installation, will be invoiced at prevailing rates.

This is to certify that the Trane® equipment has been properly and completely installed, and that the applicable items listed above have been satisfactorily completed.

Important: It is required that the chiller heaters are energized for a minimum of 24 hours prior to start up. Therefore, the chiller should have power for this amount of time before Trane Service arrives to do start-up of the equipment.

Checklist completed by: _____

Signed: _____ Date: _____

In accordance with your quotation and our purchase order number _____, we will therefore require the presence of Trane service on this site, for the purpose of start-up and commissioning, by _____ (date).

Note: Minimum two-week advance notification is required to allow scheduling of the chiller start-up.

Additional comments/instructions: _____

Note: A copy of this completed form must be submitted to the Trane Service Office that will be responsible for start-up of chiller.



Ingersoll Rand (NYSE:IR) advances the quality of life by creating comfortable, sustainable and efficient environments. Our people and our family of brands—including Club Car®, Ingersoll Rand®, Thermo King® and Trane®—work together to enhance the quality and comfort of air in homes and buildings; transport and protect food and perishables; and increase industrial productivity and efficiency. We are a global business committed to a world of sustainable progress and enduring results.



ingersollrand.com

Ingersoll Rand has a policy of continuous product and product data improvement and reserves the right to change design and specifications without notice.
We are committed to using environmentally conscious print practices.



Ingersoll Rand (NYSE:IR) advances the quality of life by creating comfortable, sustainable and efficient environments. Our people and our family of brands—including Club Car®, Ingersoll Rand®, Thermo King® and Trane®—work together to enhance the quality and comfort of air in homes and buildings; transport and protect food and perishables; and increase industrial productivity and efficiency. We are a global business committed to a world of sustainable progress and enduring results.



ingersollrand.com

Ingersoll Rand has a policy of continuous product and product data improvement and reserves the right to change design and specifications without notice.
We are committed to using environmentally conscious print practices.