

**MCQ Practice Test 4**  
**Answer Key and Solutions**



## Answer Key

1. B	11. D	21. B	31. C
2. C	12. D	22. B	32. A
3. A	13. B	23. A	33. C
4. C	14. A	24. D	34. C
5. B	15. C	25. A	35. B
6. D	16. B	26. C	36. A
7. A	17. B	27. C	37. C
8. B	18. D	28. D	38. B
9. C	19. A	29. D	39. B
10. D	20. A	30. D	40. A

**Solutions are on the following pages**



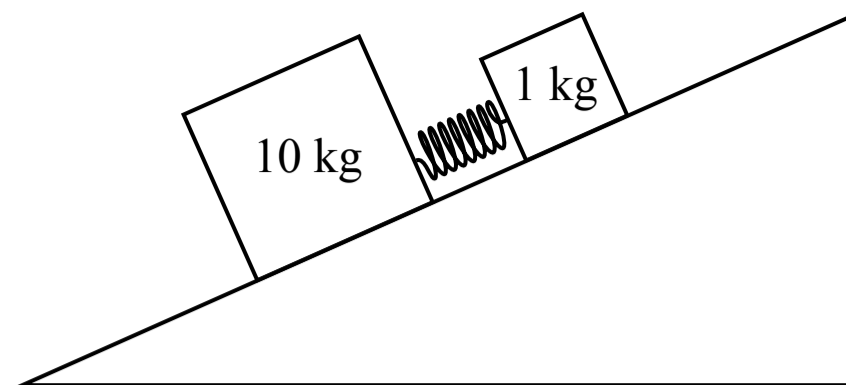

1. Two blocks are connected by a spring and placed on an incline with negligible friction. The blocks are held so that the spring is initially compressed. The blocks are then released from rest and they move apart from each other due to the spring. After the blocks are released, the location of the center of mass of the blocks-spring system
- (A) will move up the incline
  - (B) will move down the incline
  - (C) will not move
  - (D) the motion of the center of mass cannot be determined

A Incorrect

B **Correct**

The system is defined as the two blocks and the spring. The spring force acting on the blocks is an internal force. There is no friction force acting on the blocks but there is a weight force acting on each block, so the net external force acting on the system is equal to the total weight force and is not zero. The weight force acts vertically downwards and there is a component of the weight force which is parallel to the incline, so the center of mass of the system accelerates down the incline.

C Incorrect

D Incorrect

Related course pages: [2 - Newton's 2nd Law](#), [2 - Gravity & Weight](#)

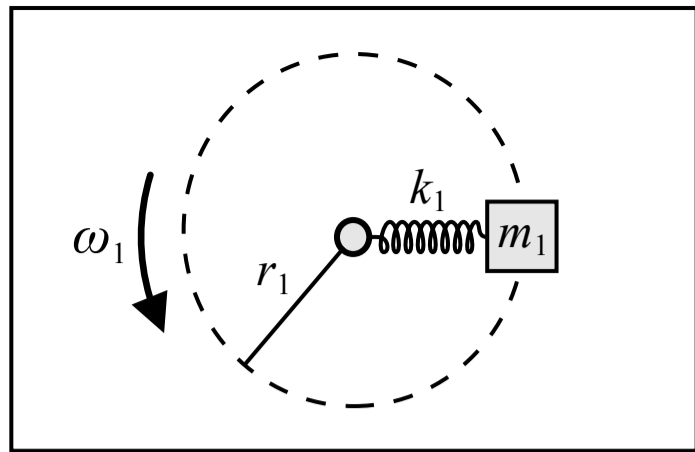

Top view

Figure 1

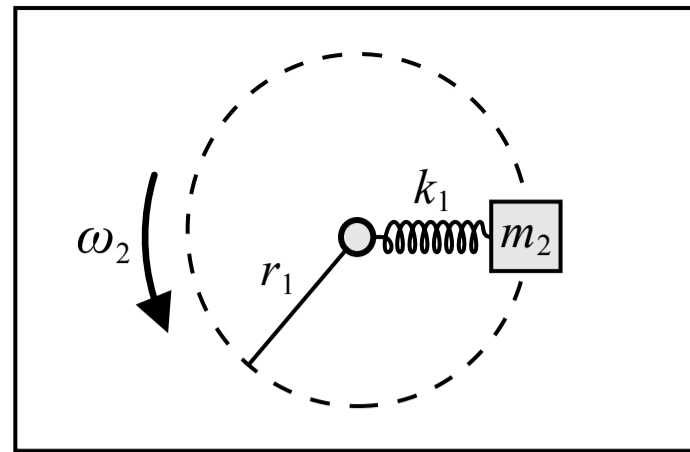

Top view

Figure 2

2. In Figure 1 above a small block of mass  $m_1$  is attached to one end of a spring with a spring constant of  $k_1$  and the other end of the spring is attached to an axle which passes through a hole in the table. A motor below the table causes the axle to rotate with a constant angular speed of  $\omega_1$  and the block travels in a horizontal circle with a radius of  $r_1$  on the surface of the table which has negligible friction. In Figure 2 the block is replaced with a different block that has the same dimensions but a mass of  $m_2$  where  $m_2 > m_1$ . The motor now rotates the axle with a constant angular speed of  $\omega_2$  so that the radius of the circular path is still  $r_1$ . How does  $\omega_2$  compare to  $\omega_1$ ?

- (A)  $\omega_1 < \omega_2$   
 (B)  $\omega_1 = \omega_2$   
 (C)  $\omega_1 > \omega_2$   
 (D) Cannot be determined

(A) Incorrect

(B) Incorrect

**(C) Correct**

The spring force acting on the block is providing the centripetal force that is required to keep the block moving in circular motion (and not moving out away from the circle in a tangent line due to its inertia). The spring force is equal to the centripetal force and the variables are related as shown below. The radius  $r$  is the same so the change in length of the spring  $\Delta x$  is also the same. The spring constant  $k$  is the same. If the mass  $m$  is increased then the angular speed  $\omega$  must decrease.

$$\Sigma F = ma \quad F_{\text{sp}} = \frac{mv^2}{r} = \frac{m(r\omega)^2}{r} = mr\omega^2 \quad k\Delta x = mr\omega^2 \quad \frac{k\Delta x}{mr} = \omega^2$$

(D) Incorrect

Related course pages: 2 - Spring Force & Hooke's Law, 2 - Centripetal Acceleration and Force

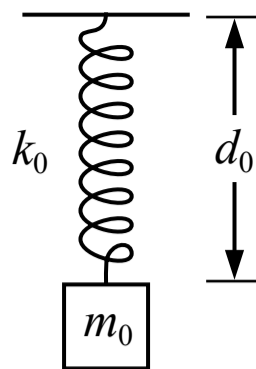

3. A block of mass  $m_0$  is suspended from the ceiling by a spring with a spring constant of  $k_0$ . The block is pulled down to a distance of  $d_0$  from the ceiling and released from rest, and the block oscillates up and down. Which of the following changes would increase the frequency of the oscillation?

- (A) Replace the block with a different block of mass  $m_0/2$
- (B) Pull the block down to a distance of  $2d_0$
- (C) Replace the spring with a different spring with a spring constant of  $k_0/2$  and the same original length
- (D) Pull the block down to a distance of  $d_0/2$

**A Correct**

The equation for the period and frequency of a mass-spring oscillation is shown below. Decreasing the mass would increase the frequency of the oscillation.

$$f_{\text{sp}} = \frac{1}{T_{\text{sp}}} = \frac{1}{2\pi} \sqrt{\frac{k}{m}}$$

**B Incorrect**

The frequency of the oscillation is not related to the amplitude, so changing the original height of the block would not affect the frequency.

**C Incorrect**

Decreasing the spring constant would decrease the frequency of the oscillation.

**D Incorrect**

The frequency of the oscillation is not related to the amplitude, so changing the original height of the block would not affect the frequency.

Related course pages: [7 - Simple Harmonic Motion](#)

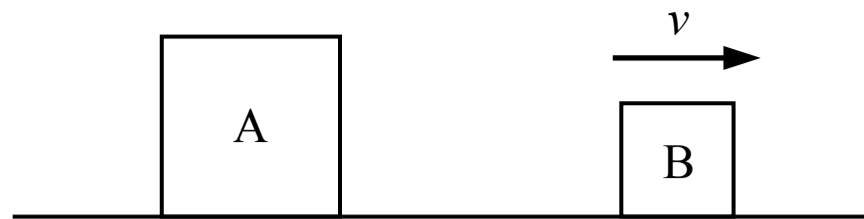

4. Block A is sitting on the ground at rest and block B is moving with a constant velocity as shown in the figure above. The mass of block A is greater than the mass of block B. Which of the following is true of the net force acting on block A and the net force acting on block B?
- (A) The net force on block A is greater than the net force on block B
  - (B) The net force on block B is greater than the net force on block A
  - (C) The net force on block A is equal to the net force on block B
  - (D) The relationship between the net force on block A and block B cannot be determined

(A) Incorrect

(B) Incorrect

This answer incorrectly assumes that a net force is required to move block B at a constant velocity.

**(C) Correct**

According to Newton's 1st law of motion an object at rest will remain at rest, or an object will continue moving at a constant velocity if there is no net force acting on the object. Block A is at rest so there is no net force acting on it (although there may be forces acting on it which are balanced in opposite directions). Block B is moving at a constant velocity so there is no net force acting on it. The net forces are both zero.

(D) Incorrect

Related course pages: [2 - Newton's 1st Law & Forces](#)

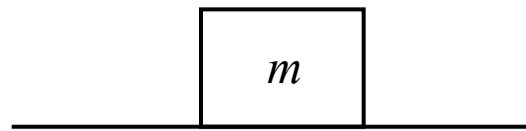

5. A block with a mass of  $m$  is sitting on the surface of a planet where the gravitational field strength is 20% of the gravitational field strength near the surface of earth. If the weight of the block on this planet is 100 N the mass of the block is most nearly

(A) 10 kg

(B) 50 kg

(C) 2 kg

(D) 13 kg

(A) Incorrect

This answer incorrectly uses  $10 \text{ m/s}^2$  for the gravitational field strength or the acceleration due to gravity on the planet.

(B) **Correct**

The weight of the block is equal to the mass multiplied by the gravitational field strength or the acceleration due to gravity. The gravitational field strength on the planet would be 20% of  $10 \text{ m/s}^2$  (or  $10 \text{ N/kg}$ ).

$$w = F_g = mg \quad (100 \text{ N}) = m(0.2)(10 \text{ m/s}^2) \quad m = 50 \text{ kg}$$

(C) Incorrect

This answer incorrectly divides  $10 \text{ m/s}^2$  by 0.2 to get  $50 \text{ m/s}^2$  for the gravitational field strength or the acceleration due to gravity on the planet.

(D) Incorrect

This answer incorrectly uses 80% of  $10 \text{ m/s}^2$  for the gravitational field strength of the acceleration due to gravity on the planet.

Related course pages: 2 - Gravity & Weight

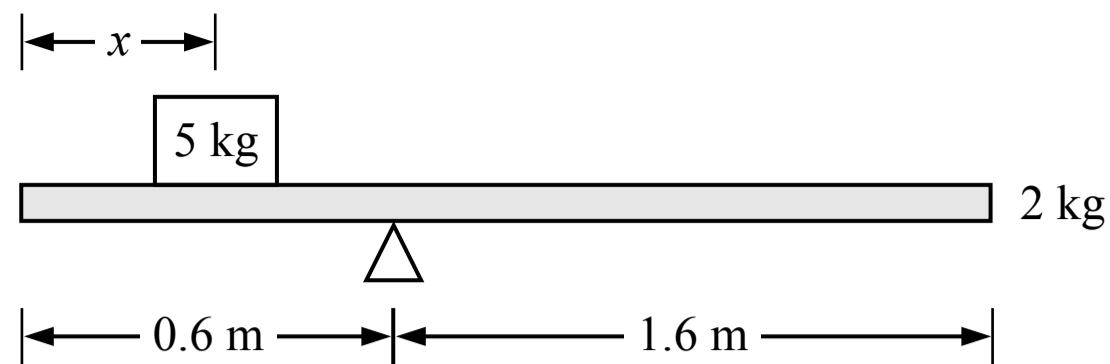

Note: Figure not drawn to scale.

6. A 2 kg beam is resting on a pivot point and a 5 kg block is resting on the beam as shown in the figure above. If the beam and the block remain at rest, what is the distance between the center of the block and the left end of the beam?

- (A) 0.8 m
- (B) 0.2 m
- (C) 0.6 m
- (D) 0.4 m

**A** Incorrect

This answer incorrectly adds the torques from the block and the beam. The torques act in opposite directions so one torque must be negative.

**B** Incorrect

This answer incorrectly uses  $x$  as the distance between the block and the point of rotation.

**C** Incorrect

This answer only includes the torque produced by the block and excludes the torque produced by the beam.

**D** Correct

The beam remains at rest so the angular acceleration of the beam is zero and the net torque acting on the beam about the point of rotation is zero. The weight force of the 5 kg block acts at the center of the block and produces a torque about the pivot point. The weight force of the beam acts at the center of the beam and also produces a torque about the pivot point. The beam is 2.2 m long so the center of the beam is 1.1 m from the left end or 0.5 m to the right of the pivot point. The torques act in opposite directions.

$$\Sigma \tau = \tau_{\text{block}} - \tau_{\text{beam}} = I(0 \text{ rad/s}^2) \quad rF_{\text{block}} - rF_{\text{beam}} = 0 \quad (0.6 \text{ m} - x)(5 \text{ kg})g - (0.5 \text{ m})(2 \text{ kg})g = 0$$

$$x = 0.4 \text{ m}$$

Related course pages: [5 - Torque](#), [5 - Rotational Dynamics](#)

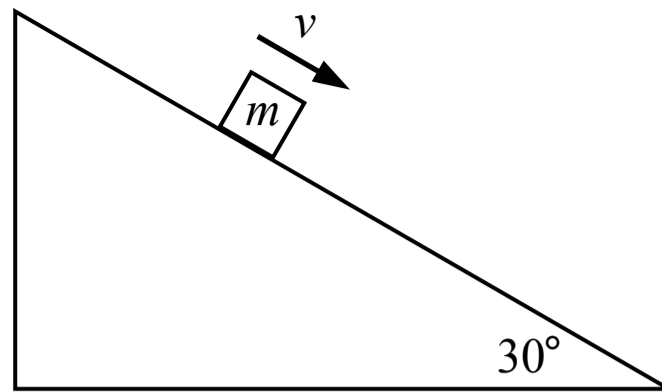

7. A block slides down an incline with a constant speed as shown in the figure above. The friction between the incline and the block is not negligible. Which of the following statements is true about the work done on the block?

- (A) The magnitude of the work done by gravity is equal to the magnitude of the work done by friction
- (B) The magnitude of the work done by friction is equal to the magnitude of the work done by the normal force
- (C) The magnitude of the work done by gravity is greater than the magnitude of the work done by friction
- (D) The magnitude of the work done by gravity is equal to the magnitude of the work done by the normal force

**A Correct**

The block moves at a constant speed so the acceleration and the net force on the block are zero (Newton's 1st law). The component of the weight force on the block that acts parallel to the incline must be equal to the friction force on the block (which acts in the opposite direction) and each force is applied over the same distance. The work done by a force is the component of the force in the direction of the motion multiplied by the distance the object moves, so the magnitudes of the work done by gravity and friction are equal:

$$W = F_{\parallel} d \quad \Sigma F_{\parallel} = F_{g\parallel} - f_k = 0 \quad F_{g\parallel} = f_k$$

We can also say the net work done on the block is equal to the change in the kinetic energy of the block. The block has a constant speed so the kinetic energy is constant and the net work done on the block is zero. The only two forces doing work on the block are gravity (which does positive work) and friction (which does negative work) so the work done by each force must have the same magnitude:

$$\Sigma W = \Delta K = 0 \quad W_g - W_f = 0 \quad W_g = W_f$$

**B Incorrect**

The work done by the normal force is zero because the force is perpendicular to the motion of the block.

**C Incorrect**

**D Incorrect**

The work done by the normal force is zero because the force is perpendicular to the motion of the block.

Related course pages: [3 - Conservation of Energy, Work & Power](#)

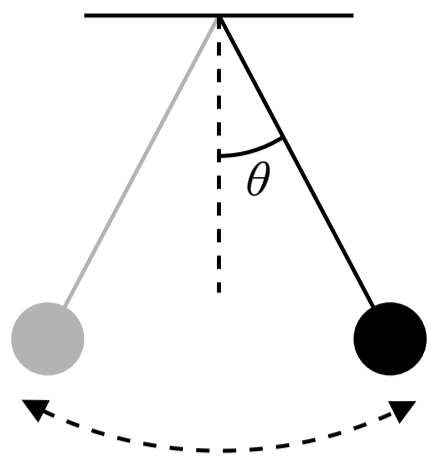

Note: Figure not drawn to scale

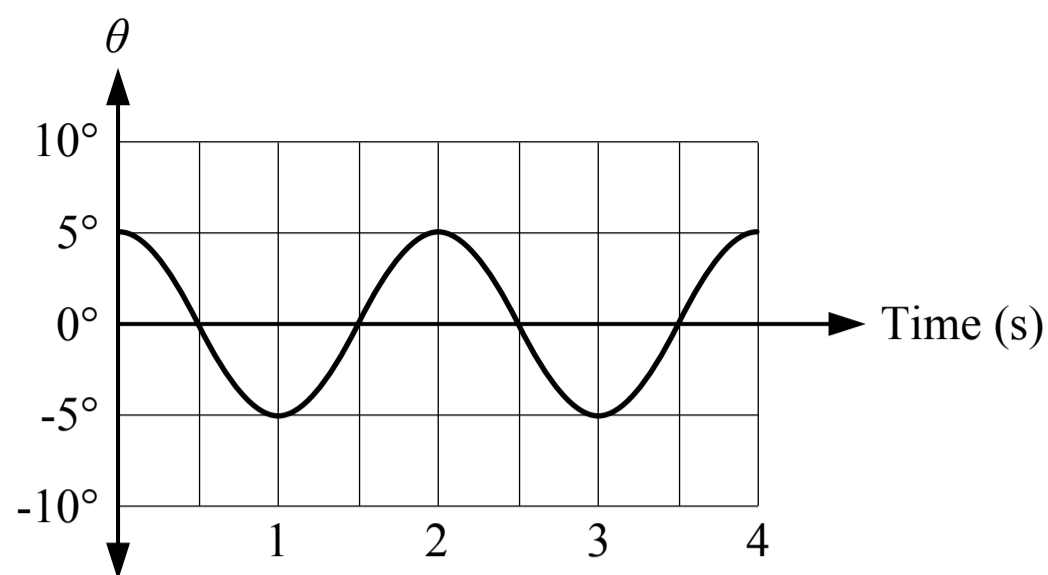

8. A graph of the motion of a pendulum is shown in the figure above. The angle of the pendulum is measured relative to the vertical. Which of the following is true about the motion of the pendulum?

- (A) The angular velocity of the pendulum at 1.5 seconds is zero
- (B) The angular velocity of the pendulum at 3 seconds is zero
- (C) The angular velocity of the pendulum is never zero
- (D) The angular velocity of the pendulum is always zero

**A** Incorrect

The angular position is zero at 1.5 seconds but the angular velocity (the slope) is not zero.

**B** Correct

The graph is an angular position-time graph so the slope of the graph is the angular velocity. The slope of the graph and the angular velocity are zero at 3 seconds.

**C** Incorrect

The angular velocity (the slope) is zero at 0, 1, 2, 3 and 4 seconds.

**D** Incorrect

The angular velocity (the slope) is not always zero.

Related course pages: 5 - Rotational Motion, 7 - Simple Harmonic Motion

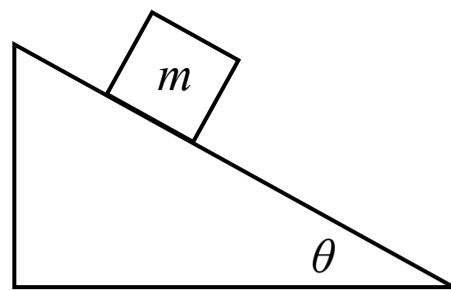

9. A block with a mass of  $m$  is sitting at rest on an incline as shown in the figure above. The coefficient of static friction between the block and the incline surface is  $\mu_s$ . Which of the following must be equal to the magnitude of the friction force acting on the block?

(A)  $\mu_s m g \cos(\theta)$

(B)  $\mu_s m g \sin(\theta)$

(C)  $m g \sin(\theta)$

(D)  $\mu_s m g$

**A** Incorrect

This answer is the maximum possible static friction force that could be acting on the block using the equation  $f_{s \max} = \mu_s F_n$ . However, the actual magnitude of the static friction force may be less than that.

**B** Incorrect

This answer incorrectly uses the equation for the maximum possible static friction force, and incorrectly uses  $m g \sin(\theta)$  for the normal force instead of  $m g \cos(\theta)$ .

**C** Correct

The block is at rest and not accelerating so the net force parallel to the incline surface is zero. The magnitude of the static friction force (acting up the incline) must be equal to the magnitude of the component of the weight force parallel to the incline (acting down the incline) which is  $m g \sin(\theta)$ . Remember that the maximum possible static friction force depends on the normal force,  $f_{s \max} = \mu_s F_n$ , but the actual static friction force may be less than that and depends on the other forces acting along the same axis.

**D** Incorrect

This answer incorrectly uses the equation for the maximum possible static friction force, and incorrectly uses  $m g$  for the normal force instead of  $m g \cos(\theta)$ .

Related course pages: [2 - Newton's 1st Law & Forces](#), [2 - Friction](#)

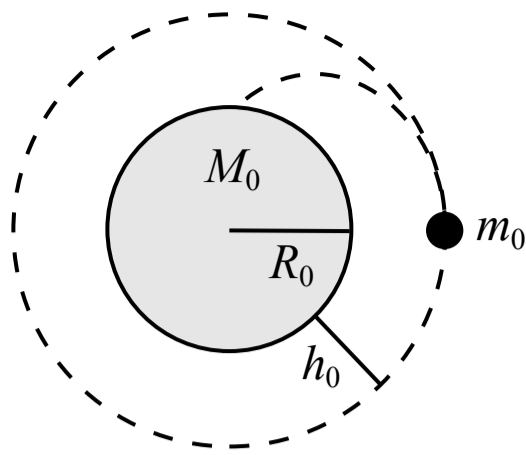

10. A space capsule with a mass  $m_0$  of 500 kg is launched into a circular orbit at a height  $h_0$  of 400 km above the surface of a planet which has a mass  $M_0$  of  $1 \times 10^{24}$  kg and a radius of  $1 \times 10^6$  m. What is the speed of the capsule in orbit?

- (A)  $8.2 \times 10^6$  m/s
- (B)  $12.9 \times 10^3$  m/s
- (C)  $8.2 \times 10^3$  m/s
- (D)  $6.9 \times 10^3$  m/s

**A** Incorrect

This answer incorrectly uses  $r$  instead of  $r^2$  in the equation for gravitational force.

**B** Incorrect

This answer incorrectly uses  $h_0$  instead of  $(R_0 + h_0)$  for the radius of the orbit.

**C** Incorrect

This answer incorrectly uses  $R_0$  instead of  $(R_0 + h_0)$  for the radius of the orbit, or incorrectly uses 400 m instead of 400 km for  $h_0$ .

**D** Correct

The capsule is in uniform circular motion around the planet and the gravitational force is acting as the centripetal force. The mass of the capsule is not relevant to the speed.

$$F_c = F_g \quad \frac{mv^2}{r} = \frac{GMm}{r^2} \quad \frac{v^2}{(R_0 + h_0)} = \frac{GM_0}{(R_0 + h_0)^2} \quad v^2 = \frac{(6.67 \times 10^{-11})(1 \times 10^{24} \text{ kg})}{(1 \times 10^6 \text{ m}) + (400,000 \text{ m})} \quad v = 6.9 \times 10^3 \text{ m/s}$$

Related course pages: 2 - Gravity & Weight, 2 - Centripetal Acceleration and Force, 2 - Orbital Motion

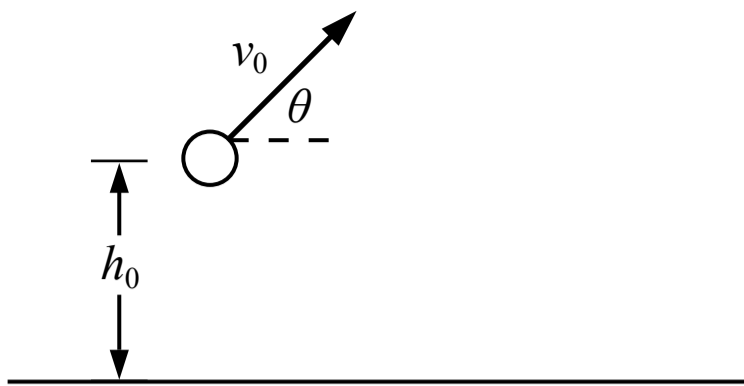

11. A ball at a height  $h_0$  above the ground is given initial velocity  $v_0$  as shown in the figure above. The magnitude of the velocity at the moment before the ball lands on the ground is

- (A)  $\sqrt{(v_0 \cos\theta)^2 + (v_0 \sin\theta)^2}$
- (B)  $\sqrt{(v_0 \cos\theta)^2 + (v_0 \sin\theta)^2 - 2gh_0}$
- (C)  $v_0 \sin\theta$
- (D)  $\sqrt{(v_0 \cos\theta)^2 + (v_0 \sin\theta)^2 + 2gh_0}$

**A** Incorrect

This answer is the magnitude of the initial velocity  $v_0$ .

**B** Incorrect

This answer is similar to the correct answer but either  $g$  or  $h_0$  have the opposite sign.

**C** Incorrect

This answer is the vertical component of the initial velocity  $v_0$ .

**D** Correct

The initial horizontal and vertical velocity components are  $v_{xi} = v_0 \cos\theta$  and  $v_{yi} = v_0 \sin\theta$ . The final horizontal velocity component is the same as the initial component because the horizontal velocity is constant in projectile motion:  $v_{xf} = v_{xi} = v_0 \cos\theta$ . The final vertical velocity component can be found using this kinematic equation below. The acceleration and the vertical displacement must have the same sign.

$$v_{yf}^2 = v_{yi}^2 + 2a_y\Delta y \quad v_{yf}^2 = (v_0 \sin\theta)^2 + 2(-g)(-h_0)$$

The magnitude of the final velocity can be found using the Pythagorean theorem and the final components:

$$v_f^2 = v_{xf}^2 + v_{yf}^2 \quad v_f = \sqrt{v_{xf}^2 + v_{yf}^2} = \sqrt{(v_0 \cos\theta)^2 + (v_0 \sin\theta)^2 + 2gh_0}$$

Related course pages: [1 - 2D Motion & Vectors](#), [1 - Projectile Motion](#)

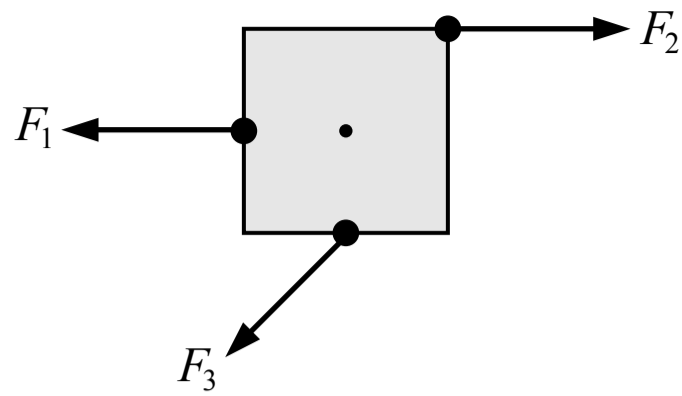

12. Three forces with equal magnitude are exerted on a square which is free to rotate about the point at its center as shown in the figure above. How do the magnitudes of the torques produced by the three forces about the center compare?

- (A)  $\tau_1 = \tau_2 = \tau_3$
- (B)  $\tau_1 < \tau_2 < \tau_3$
- (C)  $\tau_3 < \tau_1 = \tau_2$
- (D)  $\tau_1 < \tau_3 < \tau_2$

(A) Incorrect

(B) Incorrect

(C) Incorrect

**(D) Correct**

The magnitude of the torque produced about a point of rotation by a force can be calculated in two ways:  $\tau = rF_{\perp} = r_{\perp}F$ .  $F_1$  acts along a line that passes through the point of rotation so no torque is produced by  $F_1$ .  $F_3$  acts at a point that is a distance from the point of rotation equal to half of the square's width, and it acts at an angle to that radial line (not perpendicular).  $F_2$  acts along a line of force that is a distance from the point of rotation that is equal to half of the square's width, and it acts perpendicular to that radial line so it produces a greater torque than  $F_3$ . This is equivalent to  $F_2$  acting at the same point as  $F_3$ .

Related course pages: 5 - Torque



13. Block A is held in place against a spring which is initially compressed a distance of  $\Delta x_0$  from its original length. Block A is then released, moves to the right and loses contact with the spring. Block A slides across the surface where friction is negligible and it collides and sticks to block B which is initially at rest. Which of the following is an expression for the speed of the blocks after the collision?

(A)  $\sqrt{\frac{k_0 \Delta x_0^2}{m_0}}$

(B)  $\frac{1}{3} \sqrt{\frac{k_0 \Delta x_0^2}{m_0}}$

(C)  $\frac{1}{2} \sqrt{\frac{k_0 \Delta x_0^2}{m_0}}$

(D) 0

(A) Incorrect

This is an expression for the speed of block A after losing contact with the spring.

**B Correct**

The speed of block A after losing contact with the spring can be found using conservation of energy (the energy of the block-spring system is conserved so the initial spring potential energy is transformed into the the final kinetic energy of block A when it loses contact with the spring). The collision between the blocks is perfectly inelastic because they stick together, and the final speed of the two blocks together can be found using conservation of momentum.

Spring and block A:  $E_i = E_f$      $U_{sp\ i} = K_f$      $\frac{1}{2} k_0 \Delta x_0^2 = \frac{1}{2} m_0 v_A^2$      $v_A = \sqrt{\frac{k_0 \Delta x_0^2}{m_0}}$

Collision:  $m_A v_{Ai} + m_B v_{Bi} = (m_A + m_B) v_f$      $(m_0) \sqrt{\frac{k_0 \Delta x_0^2}{m_0}} + (2 m_0)(0) = (m_0 + 2 m_0) v_f$      $v_f = \frac{1}{3} \sqrt{\frac{k_0 \Delta x_0^2}{m_0}}$

(C) Incorrect

(D) Incorrect

Related course pages: 3 - Conservation of Energy, Work & Power, 4 - Conservation of Momentum & Collisions

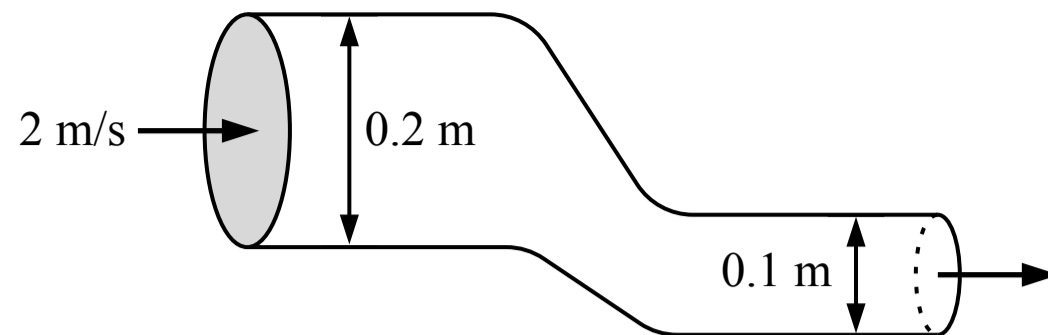

14. An ideal fluid is flowing into the tube shown in the figure above with a speed of 2 m/s. The diameter of the inlet is 0.2 m and the diameter of the outlet is 0.1 m. The volume of fluid that exits the tube over a period of 3 seconds is most nearly

- (A) 0.19 m<sup>3</sup>
- (B) 0.06 m<sup>3</sup>
- (C) 0.09 m<sup>3</sup>
- (D) 0.38 m<sup>3</sup>

**A Correct**

An ideal fluid is incompressible so the mass and volume that enters the tube over a period of time must equal the amount of mass and volume that exits the tube. The flow rates into and out of the tube are equal. The flow rate through an area is equal to the area multiplied by the speed of the flow.

$$\frac{V_{\text{in}}}{\Delta t} = \frac{V_{\text{out}}}{\Delta t} \quad A_{\text{in}} v_{\text{in}} = \frac{V_{\text{out}}}{\Delta t} \quad \pi(0.2 \text{ m} / 2)^2 (2 \text{ m/s}) = \frac{V_{\text{out}}}{(3 \text{ s})} \quad V_{\text{out}} = 0.19 \text{ m}^3$$

**B Incorrect**

This is the flow rate through the tube (0.06 m<sup>3</sup>/s) with the unit of m<sup>3</sup>.

**C Incorrect**

This answer may have been found by incorrectly dividing the volume by 2.

**D Incorrect**

This answer may have been found by incorrectly multiplying the volume by 2.

Related course pages: 8 - Flow

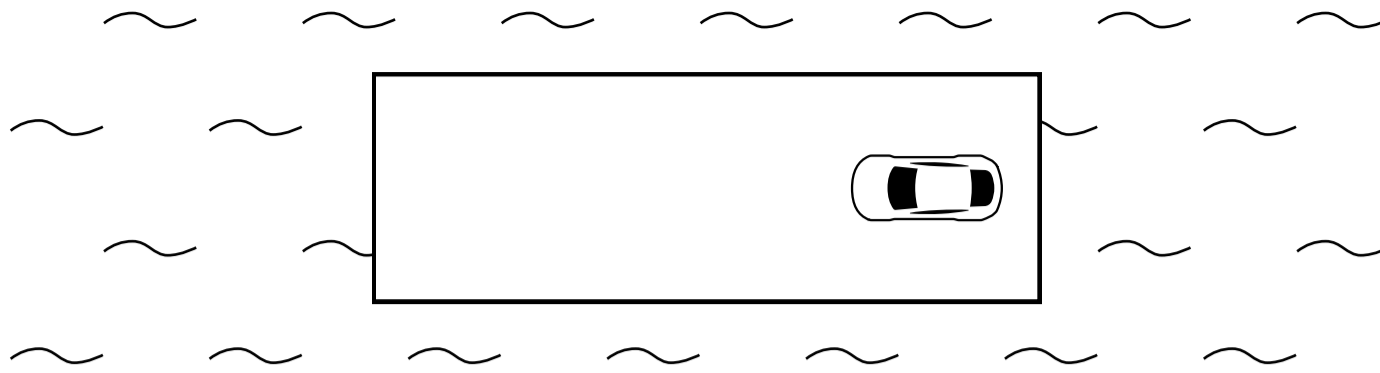

15. A car is at rest on a raft which is floating at rest in the water as shown in the top-down view in the figure above. The raft can slide through the water and the friction between the raft and the water is negligible. The car then drives to the left end of the raft and stops. After the car stops, which of the following is true?
- (A) The raft and the car are moving to the left
  - (B) The raft and the car are moving to the right
  - (C) The raft and the car are not moving
  - (D) The final motion of the raft and the car cannot be determined without knowing their masses

A Incorrect

B Incorrect

C **Correct**

The friction force acting on the raft from the water is negligible. If we consider the system of the car and the raft, there are no external forces acting on the system in the horizontal direction so the acceleration of the system's center of mass is zero (Newton's 1st law of motion). The center of mass of the system is initially at rest so the center of mass will remain at rest, and the raft and the car are not moving after the car stops.

D Incorrect

Related course pages: [2 - Newton's 1st Law & Forces](#)

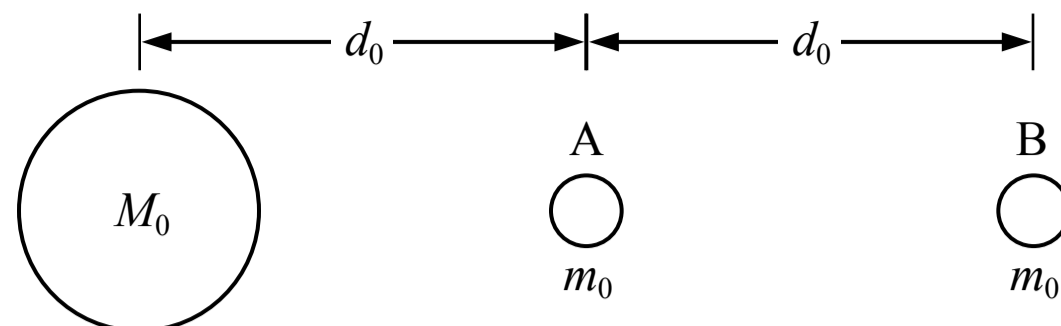

16. A planet has two moons which have the same mass and are located at the positions shown in the figure above. Which system, consisting of the planet and either one of the moons, has a greater gravitational potential energy?

(A) The planet-moon A system has a greater gravitational potential energy

(B) The planet-moon B system has a greater gravitational potential energy

(C) The systems have the same gravitational potential energy

(D) Cannot be determined

(A) Incorrect

**(B) Correct**

The gravitational potential energy of a two-mass system is given by the equation below. The gravitational potential energy is always negative. There is a greater distance between the planet and moon B so the value of  $r$  is greater and the gravitational potential energy is a smaller negative value (a value closer to zero) or a greater or more positive value than the gravitational potential energy of the planet-moon A system.

$$\text{Planet-moon A system: } U_{gA} = -\frac{GMm}{r} = -\frac{GM_0 m_0}{d_0}$$

$$\text{Planet-moon B system: } U_{gB} = -\frac{GMm}{r} = -\frac{GM_0 m_0}{2d_0} > U_{gA}$$

(C) Incorrect

(D) Incorrect

Related course pages: 3 - Types of Energy

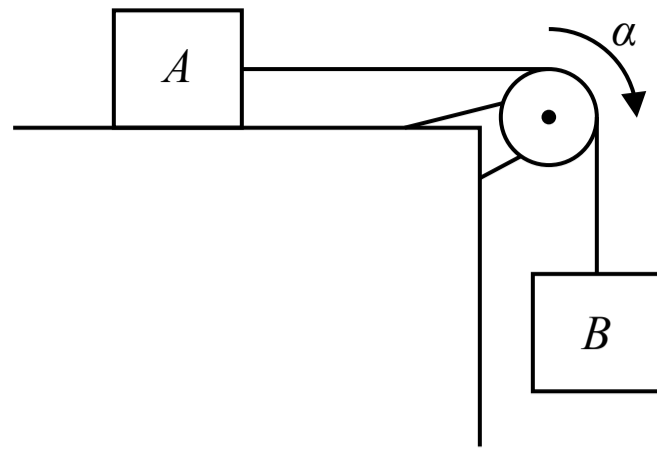

17. Two blocks are connected by a string that passes over a pulley as shown in the figure above. The blocks are released from rest, block B falls and the pulley experiences an angular acceleration. Which of the following graphs could represent the magnitude of the angular displacement of the pulley over time?

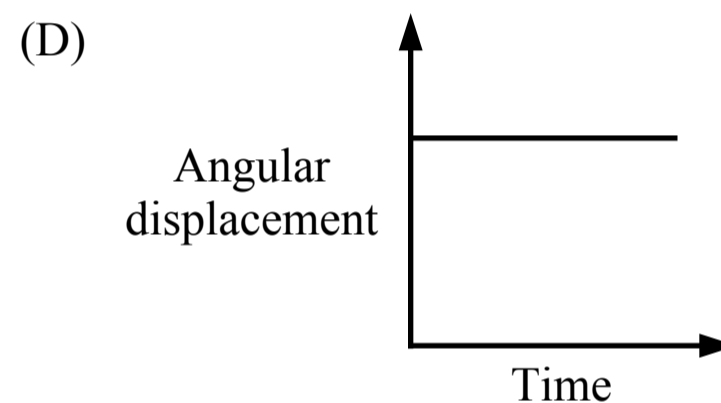
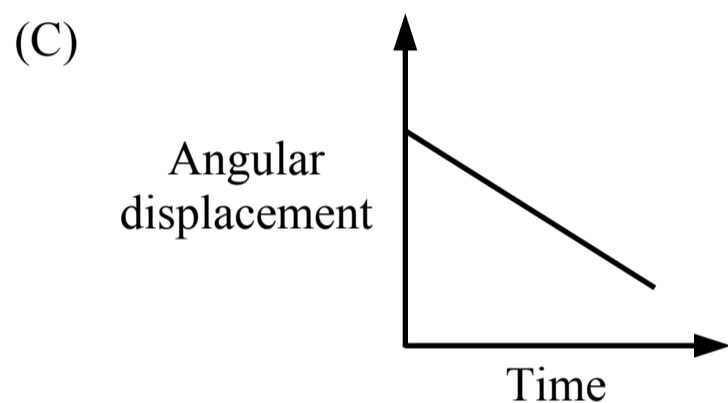
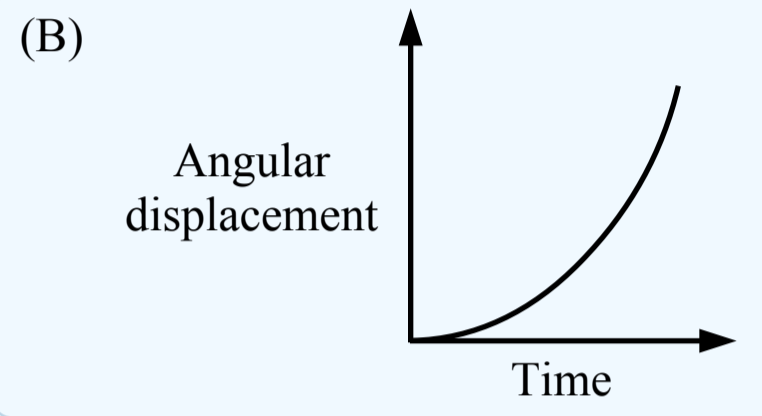

(A) Incorrect  
This graph is a straight line with a non-zero slope which represents a constant angular velocity with zero acceleration.

(B) **Correct**  
The pulley experiences an angular acceleration so the angular position-time graph and the angular displacement-time graph is a curved line. The slope of the angular displacement-time graph is the angular velocity, which is changing because there is an angular acceleration.

(C) Incorrect  
This graph is a straight line with a non-zero slope which represents a constant angular velocity with zero acceleration.

(D) Incorrect  
This graph is a straight line with zero slope which represents an angular velocity of zero.

Related course pages: 5 - Rotational Motion

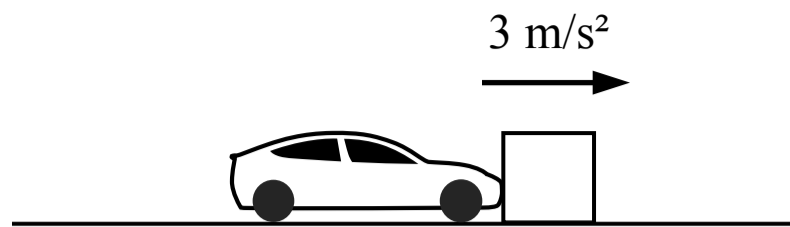

18. A car pushes a large block across a surface where friction is not negligible and the block accelerates at  $3 \text{ m/s}^2$ . Which of the following statements is true?

- (A) The block does not exert a force on the car
- (B) The force exerted on the block by the car is greater in magnitude than the force exerted on the car by the block
- (C) The force exerted on the block by the car is smaller in magnitude than the force exerted on the car by the block
- (D) The force exerted on the block by the car is equal in magnitude to the force exerted on the car by the block

A Incorrect

B Incorrect

C Incorrect

D **Correct**

The car and the block are in contact with each other so the force exerted on the block by the car is equal in magnitude and opposite in direction to the force exerted on the car by the block (Newton's 3rd law of motion) regardless of the motion.

Related course pages: [2 - Newton's 3rd Law & Normal Force](#)

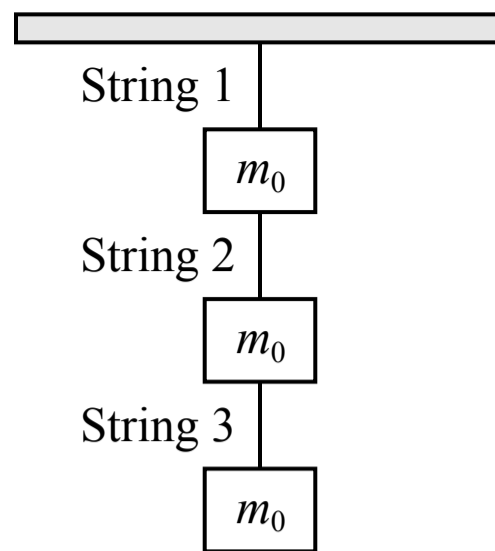

19. Three blocks with equal mass are suspended from the ceiling using three strings as shown in the figure above. If string 1 is cut, which of the following is an expression for the tension in string 2?

- (A) 0
- (B)  $m_0 g$
- (C)  $2 m_0 g$
- (D)  $3 m_0 g$

**A Correct**

When string 1 is cut the tension in string 1 becomes zero and there is no upwards force acting on the top block, or the system of the three blocks. The three blocks will be in free fall and accelerate downwards together at  $g$ ,  $9.8 \text{ m/s}^2$ . If each individual block accelerates downwards at  $g$  then the net force acting on each block is only the weight force on that block, and there are no tension forces acting on the blocks (the tension in strings 2 and 3 is zero). If there were tension in strings 2 and 3, the top block would accelerate downwards faster than  $g$  and the bottom block would accelerate downwards slower than  $g$  and the blocks would move towards each other and compress or buckle the strings and there could not be tension in the strings.

- (B) Incorrect
- (C) Incorrect
- (D) Incorrect

Related course pages: [2 - Newton's 2nd Law](#), [2 - Tension & Pulley Systems](#)

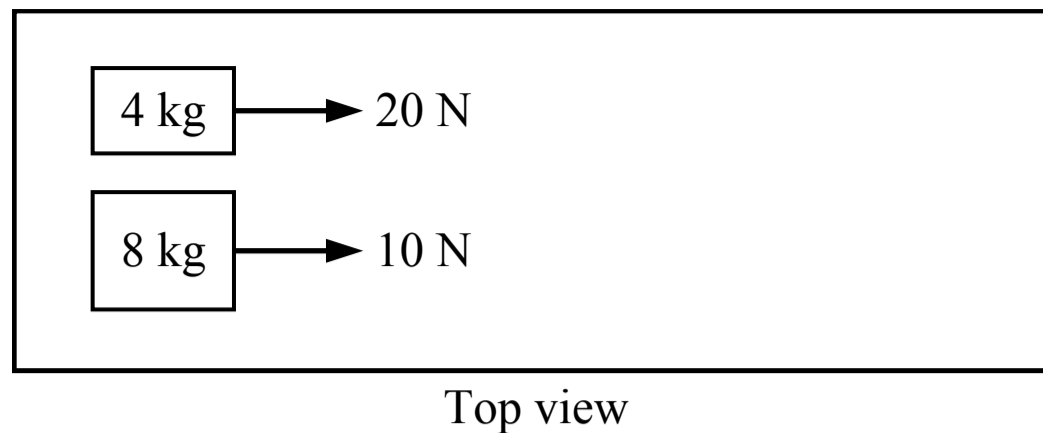

20. Two blocks are initially at rest on a table where the friction is negligible. A force is then applied to each block as shown in the figure above. Which block has a momentum with a greater magnitude after 3 seconds?

- (A) The 4 kg block
- (B) The 8 kg block
- (C) The blocks have momentums with equal magnitudes
- (D) Cannot be determined

**A Correct**

The change in momentum of a block (the impulse) is equal to the average force applied to the block multiplied by the period of time the force is applied. Both blocks start from rest with zero momentum and the forces are applied for the same period of time (3 seconds). The 4 kg block experiences a greater force so it has a greater increase in momentum and a greater momentum after 3 seconds.

$$4 \text{ kg block: } \Delta p = F_{\text{avg}} \Delta t = (20 \text{ N})(3 \text{ s}) = 60 \text{ kg}\cdot\text{m/s}$$

$$8 \text{ kg block: } \Delta p = F_{\text{avg}} \Delta t = (10 \text{ N})(3 \text{ s}) = 30 \text{ kg}\cdot\text{m/s}$$

(B) Incorrect

(C) Incorrect

(D) Incorrect

Related course pages: [4 - Linear Momentum & Impulse](#)

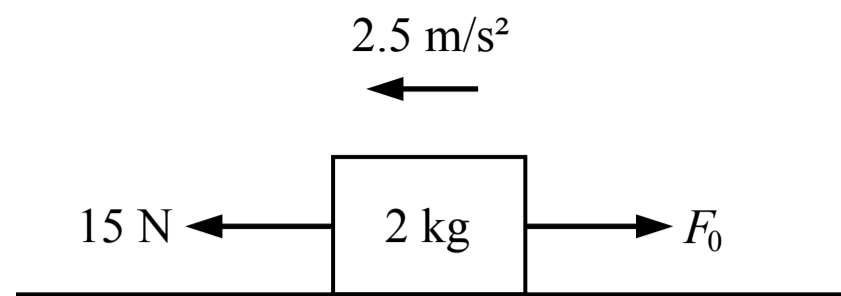

Note: Figure not drawn to scale.

21. A 2 kg block slides along a frictionless surface as shown in the figure above with an acceleration of  $2.5 \text{ m/s}^2$ . Two horizontal forces are acting on the block. What is the magnitude of force  $F_0$  ?

- (A) 20 N
- (B) 10 N
- (C) 15 N
- (D) 5 N

(A) Incorrect

This answer incorrectly switches some of the positive and negative values, such as treating the 15 N force as negative and the acceleration as positive:

$$F_0 - 15 \text{ N} = (2 \text{ kg})(2.5 \text{ m/s}^2) \quad F_0 = 20 \text{ N}$$

(B) **Correct**

Newton's 2nd law of motion can be used to relate the forces, the mass and the acceleration in the horizontal direction to solve for  $F_0$ . If we say left is the positive direction:

$$\Sigma F = ma \quad 15 \text{ N} - F_0 = (2 \text{ kg})(2.5 \text{ m/s}^2) \quad F_0 = 10 \text{ N}$$

(C) Incorrect

This answer incorrectly assumes that  $F_0$  has the same magnitude as the 15 N force.

(D) Incorrect

This answer incorrectly multiplies the mass and the acceleration and assumes that should be the magnitude of the force  $F_0$ :

$$(2 \text{ kg})(2.5 \text{ m/s}^2) = 5 \text{ N}$$

Related course pages: [2 - Newton's 2nd Law](#)

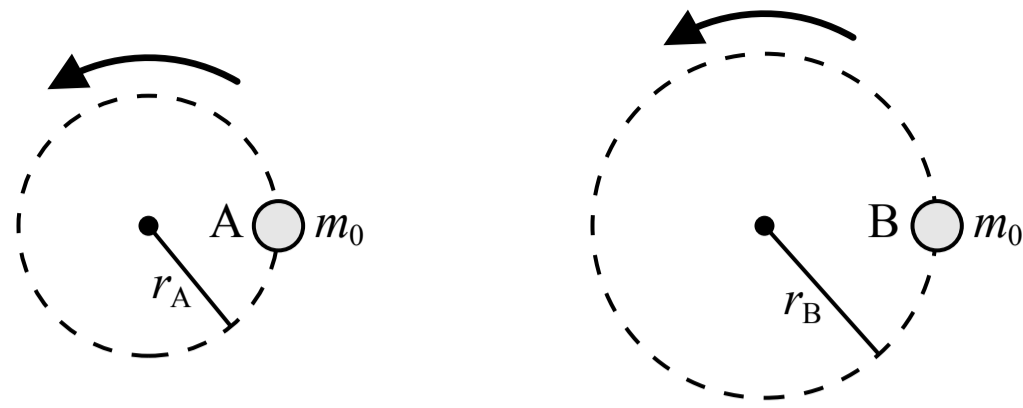

22. Two objects with the same mass are in uniform circular motion. Object A follows a circular path with radius  $r_A$  and object B follows a circular path with a radius of  $r_B > r_A$ . If the period of each object's circular motion is the same, the magnitude of the net force acting on object A is

- (A) equal to the net force acting on object B
- (B) less than the net force acting on object B
- (C) greater than the net force acting on object B
- (D) a comparison between the net force on object A and object B cannot be determined

(A) Incorrect

**(B) Correct**

The objects are in uniform circular motion so the net force acting on each object is a centripetal force which is related to the mass, speed and radius of the circular motion in the equation below. The variable for speed can be replaced with the circumference of the circle divided by the period of the motion to get a relationship between the net force (the centripetal force), the radius, the mass and the period. If object B is moving around a circle with a greater radius and the mass and period are the same for both objects, the net force on object B is greater.

$$\Sigma F = F_c = \frac{mv^2}{r} = \frac{m}{r} \left( \frac{2\pi r}{T} \right)^2 = \frac{4\pi^2 m r^2}{r T^2} \quad \Sigma F = \frac{4\pi^2 m r}{T^2}$$

(C) Incorrect

(D) Incorrect

Related course pages: 2 - Centripetal Acceleration and Force

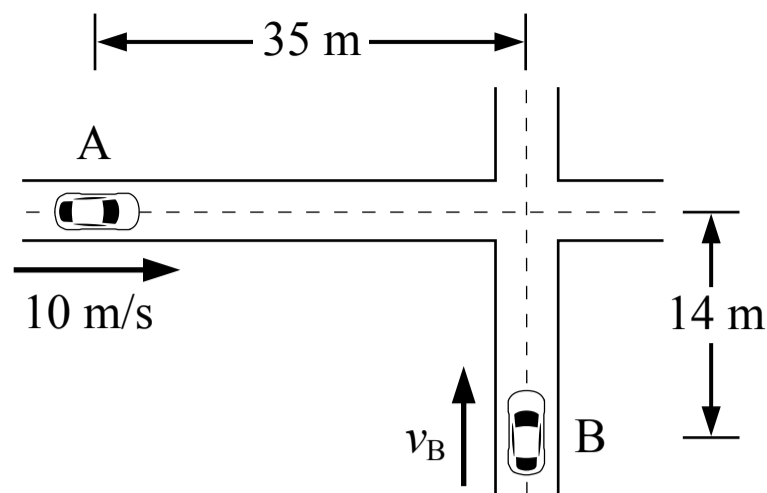

Note: Figure not drawn to scale.

23. Two cars are approaching an intersection as shown in the figure above. Car A is moving at a constant speed of 10 m/s and car B is moving at a constant speed  $v_B$ . At time  $t_0$  car A is 35 m from the middle of the intersection and car B is 14 m from the middle of the intersection. What constant speed  $v_B$  would result in the cars colliding in the intersection? You may disregard the width and length of each car and treat the cars as point masses.

- (A) 4 m/s
- (B) 10 m/s
- (C) 3.5 m/s
- (D) 8 m/s

**A Correct**

The time when car A is at the intersection can be found from its speed and distance from the intersection, then that time can be used to find the speed of car B which would result in a collision.

$$\text{Car A: } v_A = \frac{\Delta x}{\Delta t} \quad 10 \text{ m/s} = \frac{35 \text{ m}}{\Delta t} \quad \Delta t = 3.5 \text{ s}$$

$$\text{Car B: } v_B = \frac{\Delta x}{\Delta t} = \frac{14 \text{ m}}{3.5 \text{ s}} = 4 \text{ m/s}$$

**B Incorrect**

This is the speed of car A. The cars are different distances from the intersection so this would not be the speed of car B.

**C Incorrect**

This is the time that the cars would collide (3.5 s) using the unit of m/s.

**D Incorrect**

Related course pages: [1 - 1D Motion](#)

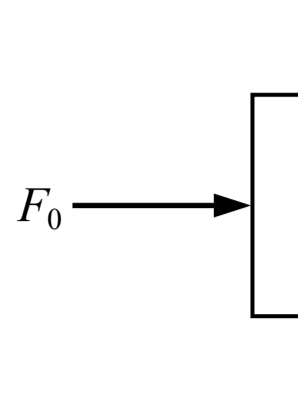

24. A person pushes horizontally on a book which is against a wall so that the book remains at rest. Which of the following shows the direction of the friction force acting on the book from the wall?

(A) 

(B) 

(C) 

(D) 

**A** Incorrect  
This is the direction of the normal force acting on the book from the wall.

**B** Incorrect  
This is the direction of the weight force acting on the book.

**C** Incorrect  
This is the direction of the force acting on the book from the person.

**D** **Correct**  
The book is at rest and not accelerating so the net force on the book is zero. There is a downwards weight force acting on the book, so the friction force acting on the book is upwards and the weight force and friction force are equal in magnitude.

Related course pages: [2 - Newton's 1st Law & Forces](#), [2 - Friction](#)

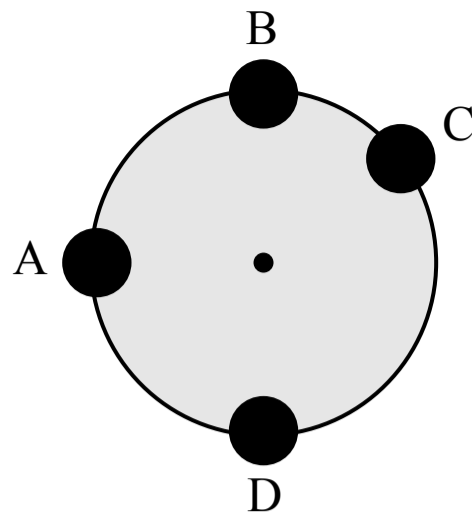

25. A large vertical wheel with uniform mass  $M$  is free to rotate on a horizontal axle passing through its center. A small sphere of mass  $m$  is attached to the outer edge of the wheel. At which of the locations shown should the small sphere be attached so that the total torque produced by the wheel and the sphere about the axle is greatest?

- (A) Location A
- (B) Location B
- (C) Location C
- (D) Location D

**A Correct**

The total torque produced by the wheel and the sphere is the sum of the torques produced by the weight force on each object. The torque is equal to the distance between the point of rotation (the axle) and the point where the force is applied, multiplied by the component of the force that is perpendicular to a line connecting the point of rotation and the point where the force is applied:  $\tau = rF_{\perp}$ . The weight force is treated as acting at the center of mass of each object, so the torque produced about the axle by the weight of the wheel is zero (the force acts directly at the point of rotation so  $r$  is zero), and the torque produced about the axle by the weight of the sphere is the radius of the wheel multiplied by the component of the sphere weight force that is perpendicular to the radius of the wheel (a line connecting the axle and the force point). That weight force is entirely perpendicular to the radius at location A, so the torque produced is the greatest.

**B Incorrect**

The torque produced by the weight of the sphere at location B is zero because the weight force is parallel to the radius of the wheel. The torque produced by the weight of the wheel is always zero in this example.

**C Incorrect**

The torque produced by the weight of the sphere at location C is less than at location A because the weight force is not entirely perpendicular to the radius of the wheel at position C. The torque produced by the weight of the wheel is always zero in this example.

**D Incorrect**

The torque produced by the weight of the sphere at location D is zero because the weight force is parallel to the radius of the wheel. The torque produced by the weight of the wheel is always zero in this example.

Related course pages: [5 - Torque](#)



26. Two blocks are sliding towards each other on a surface with negligible friction. The blocks collide, stick together and continue moving after the collision. Which of the following graphs shows the total kinetic energy of the two block system over time?

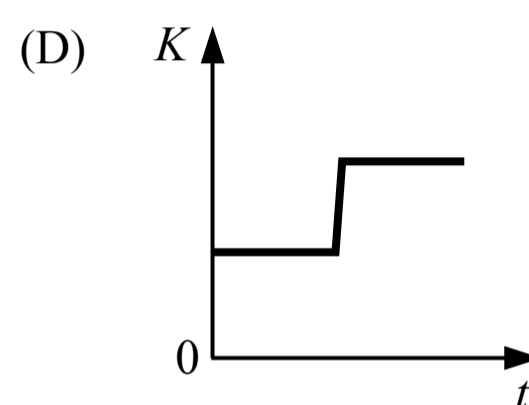
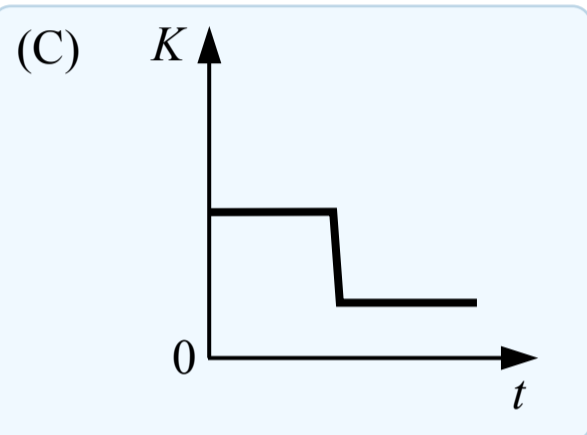
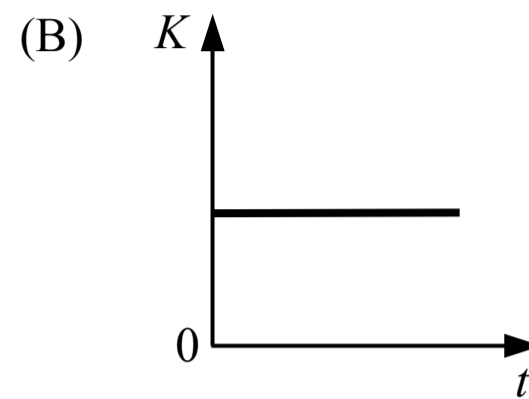
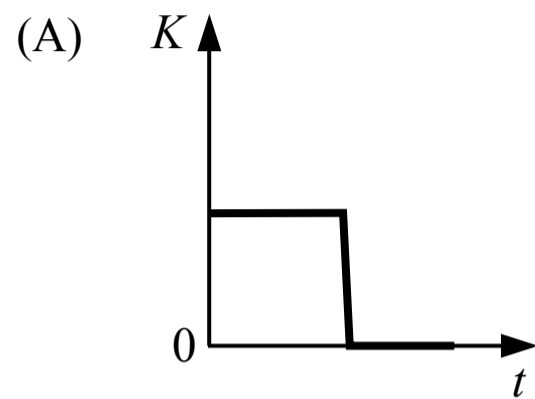

(A) Incorrect

This would be a graph of the total kinetic energy if the blocks were not moving after the collision.

(B) Incorrect

This would be a graph of the total kinetic energy during a perfectly elastic collision.

**(C) Correct**

The blocks stick together so the collision is perfectly inelastic. Momentum is conserved during the collision but kinetic energy is not conserved during a perfectly inelastic collision so it decreases. The blocks are still moving after the collision so the kinetic energy does not decrease to zero.

(D) Incorrect

This graph would not be possible during a collision like this because energy is not added to the system.

Related course pages: [3 - Types of Energy](#), [4 - Conservation of Momentum & Collisions](#)

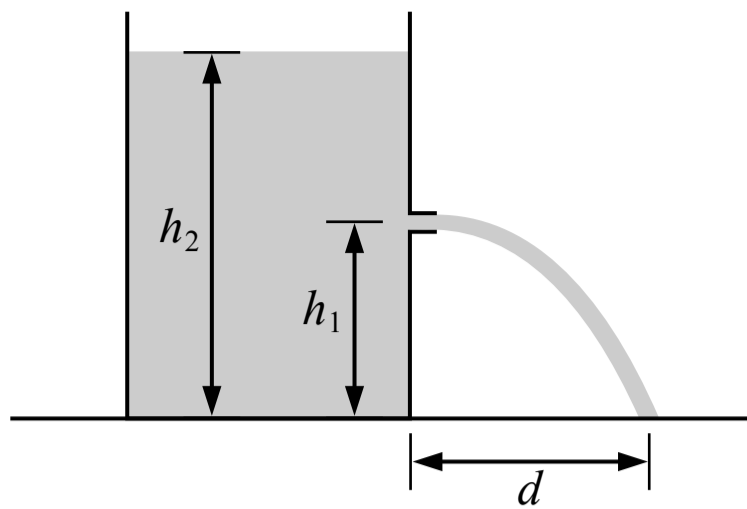

27. A large tank of oil is open at the top and has a hole in the side as shown in the figure above. A stream of oil exits the hole horizontally and then lands on the ground a distance of  $d$  from the base of the tank. The hole is at a height of  $h_1$  and the top surface of the oil is at a height of  $h_2$ . Which of the following is a correct expression for the distance  $d$  that the oil stream lands away from the tank?

- (A)  $\sqrt{\frac{2h_1}{g}}$
- (B)  $\sqrt{2g(h_2 - h_1)}$
- (C)  $\sqrt{4h_1(h_2 - h_1)}$
- (D)  $\sqrt{4(h_2 - h_1)}$

(A) Incorrect

This is an expression for the time it takes the oil to hit the ground after exiting the tank.

(B) Incorrect

This is an expression for the speed of the oil as it exits the hole.

(C) Correct

First we can use Bernoulli's equation to derive an equation for the speed of the oil stream when it exits the hole (known as Torricelli's theorem). Point 1 is at the top surface of the oil in the tank and point 2 is where the oil stream exits the hole. The oil is exposed to the atmosphere at both points so the pressure at both points is atmospheric pressure. The area of the top surface is much greater than the area of the hole so we assume that the speed at the top surface is zero.

$$P_{\text{top}} + \rho g y_{\text{top}} + \frac{1}{2} \rho v_{\text{top}}^2 = P_{\text{hole}} + \rho g y_{\text{hole}} + \frac{1}{2} \rho v_{\text{hole}}^2 \quad P_{\text{atm}} + \rho g h_2 + \frac{1}{2} \rho (0)^2 = P_{\text{atm}} + \rho g h_1 + \frac{1}{2} \rho v_{\text{hole}}^2$$

$$v_{\text{hole}} = \sqrt{2g(h_2 - h_1)}$$

Then we can use the kinematic equations from projectile motion to find the range of the stream of oil. We first need to find the time it takes the oil to fall from the hole and hit the ground, then we can use that time and the horizontal velocity to find the range.

$$y = y_0 + v_{y0}t + \frac{1}{2} a_y t^2 \quad (0 \text{ m}) = h_1 + (0 \text{ m/s})t + \frac{1}{2} (-g)t^2 \quad t = \sqrt{\frac{2h_1}{g}}$$

$$v_x = \frac{\Delta x}{t} = \frac{d}{t} \quad d = v_x t \sqrt{2g(h_2 - h_1)} \sqrt{\frac{2h_1}{g}} = \sqrt{4h_1(h_2 - h_1)}$$

(D) Incorrect

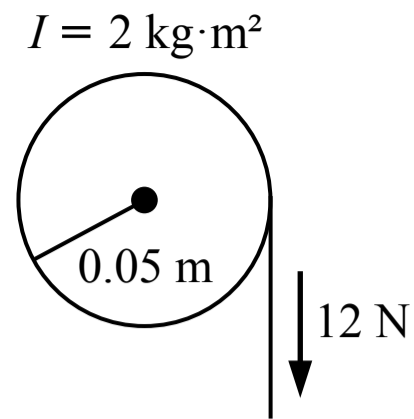

28. A string with negligible mass is wrapped around the outside of a pulley with a rotational inertia of  $2 \text{ kg}\cdot\text{m}^2$  and a radius of  $0.05 \text{ m}$  as shown in the figure above. The pulley is initially at rest when a constant  $12 \text{ N}$  force is applied to the string. The angular momentum of the pulley after a period of  $3 \text{ seconds}$  is most nearly

- (A)  $3.6 \text{ kg}\cdot\text{m}^2/\text{s}$
- (B)  $0.9 \text{ kg}\cdot\text{m}^2/\text{s}$
- (C)  $0.6 \text{ kg}\cdot\text{m}^2/\text{s}$
- (D)  $1.8 \text{ kg}\cdot\text{m}^2/\text{s}$

(A) Incorrect

(B) Incorrect

(C) Incorrect

**(D) Correct**

The initial angular momentum is zero and the change in angular momentum is equal to the torque applied multiplied by the period of time.

$$\Delta L = \tau \Delta t \quad L_f - L_i = rF_{\perp} \Delta t \quad L_f - (0) = (0.05 \text{ m})(12 \text{ N})(3 \text{ s}) \quad L_f = 1.8 \text{ kg}\cdot\text{m}^2/\text{s}$$

Related course pages: 5 - Torque, 6 - Angular Momentum

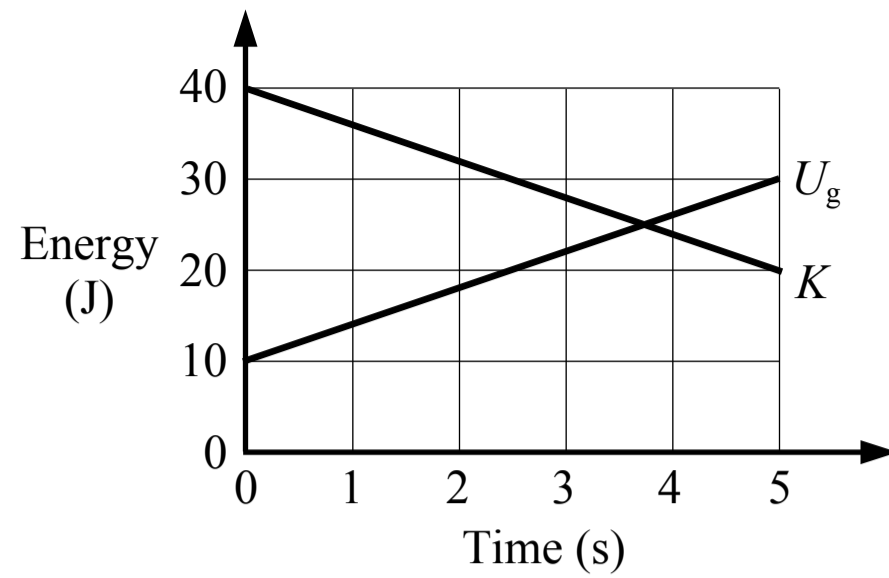

29. A graph of the energy in a system, which only has kinetic energy and gravitational potential energy, is shown in the figure above. Which of the following statements is true about this system from 0 s to 5 s?

- (A) 20 J of work is done on the system
- (B) 30 J of work is done on the system
- (C) 50 J of work is done on the system
- (D) No work is done on the system

A Incorrect

B Incorrect

C Incorrect

D **Correct**

The total amount of energy in the system remains constant (50 J) so no work is done on the system.

Related course pages: 3 - Conservation of Energy, Work & Power

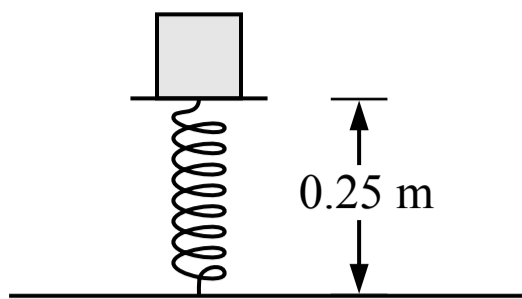

30. A block sits at rest on a spring which has a spring constant of 400 N/m and an unstretched length of 0.30 m. The block is compressing the spring as shown in the figure above. The mass of the block is most nearly

- (A) 20 kg
- (B) 12 kg
- (C) 10 kg
- (D) 2 kg

**A** Incorrect

This answer is the spring force acting on the block (20 N) using the unit of kg for mass.

**B** Incorrect

This answer incorrectly uses 0.30 m for the change in length of the spring.

**C** Incorrect

This answer incorrectly uses 0.25 m for the change in length of the spring.

**D** **Correct**

The block is at rest and not accelerating so the net force on the block is zero. The spring is compressed and there is an upwards spring force and a downwards weight force acting on the block.

$$\Sigma F_y = F_{sp} - F_g = m(0 \text{ m/s}^2) \quad k\Delta x = mg \quad (400 \text{ N/m})(0.30 \text{ m} - 0.25 \text{ m}) = mg \quad m = 2 \text{ kg}$$

Related course pages: [2 - Newton's 1st Law & Forces](#), [2 - Spring Force & Hooke's Law](#)

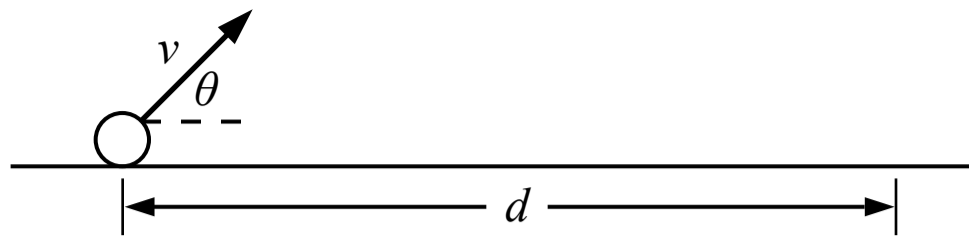

31. A projectile is launched from the ground with an initial speed and angle as shown in the figure above. It travels a distance  $d$  and lands on the ground. The projectile is launched five times with the same speed but five different angles:  $\theta_1 = 52^\circ$ ,  $\theta_2 = 38^\circ$ ,  $\theta_3 = 45^\circ$ ,  $\theta_4 = 32^\circ$ ,  $\theta_5 = 60^\circ$ . It lands at distances  $d_1$ ,  $d_2$ ,  $d_3$ ,  $d_4$  and  $d_5$  respectively. How do the distances compare to each other?

(A)  $d_4 < d_2 < d_3 < d_1 < d_5$

(B)  $d_5 < d_1 < d_3 < d_2 < d_4$

(C)  $d_5 < d_4 < d_1 = d_2 < d_3$

(D)  $d_5 < d_1 = d_4 < d_2 < d_3$

A Incorrect

B Incorrect

C Correct

For a projectile that starts and ends at the same height, the maximum range corresponds to a launch angle of  $45^\circ$  ( $\theta_3$ ). Two angles that are the same amount greater than and less than  $45^\circ$  result in the same range ( $\theta_1$  and  $\theta_2$  are both  $7^\circ$  away from  $45^\circ$ ). Angles farther from  $45^\circ$  result in a shorter range.

D Incorrect

Related course pages: [1 - Projectile Motion](#)

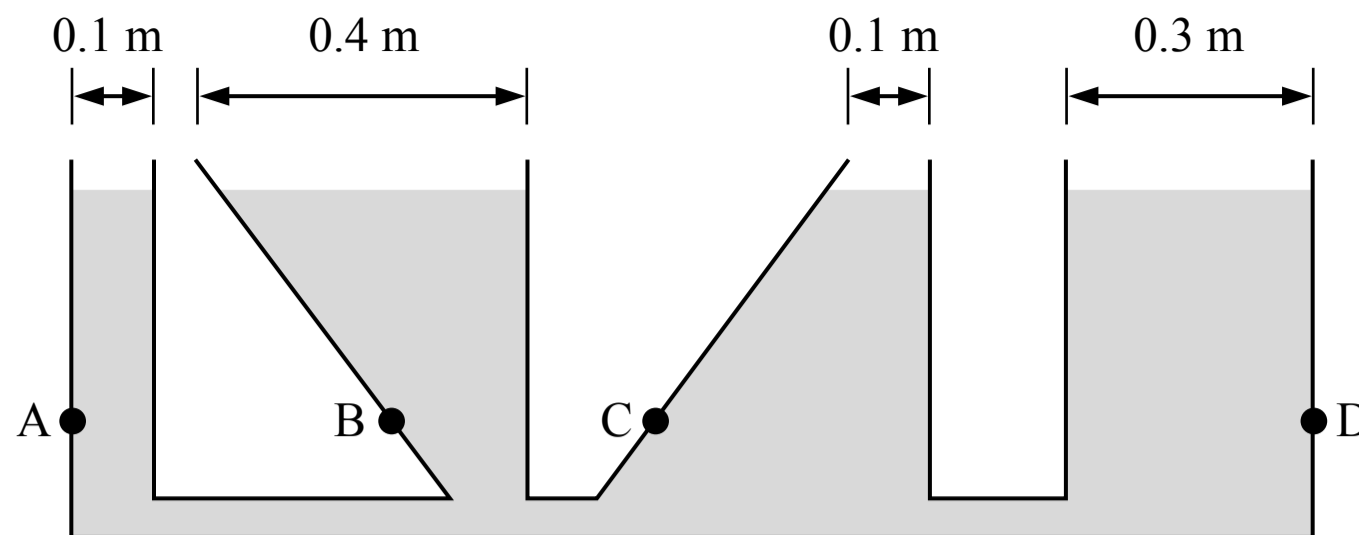

32. A large container is mostly filled with a liquid and is open at the top as shown in the figure above. The four points shown are at the same height above the bottom of the container. Which of the following correctly ranks the pressure exerted on the wall of the container by the liquid at the four points shown?

(A)  $P_A = P_B = P_C = P_D$

(B)  $(P_A = P_C) < P_D < P_B$

(C)  $P_B < P_D < (P_A = P_C)$

(D)  $P_C < (P_A = P_D) < P_B$

**A Correct**

Every point in the same fluid that is at the same level (height) is at the same pressure, so the pressure exerted on the walls at those points are the same. The shape of the container does not matter.

**B Incorrect**

This answer may have been found by incorrectly ranking the pressures based on the widths of the openings above those points, but that does not affect the pressures.

**C Incorrect**

This is the reverse ranking of option B which may have been found by incorrectly ranking the pressures based on the widths of the openings, but that does not affect the pressures.

**D Incorrect**

This answer may have been found by incorrectly assuming the slope of the wall and the direction of the pressure affects the magnitude of the pressure. The pressure at a point in a fluid acts equally in all directions.

Related course pages: [8 - Pressure](#)

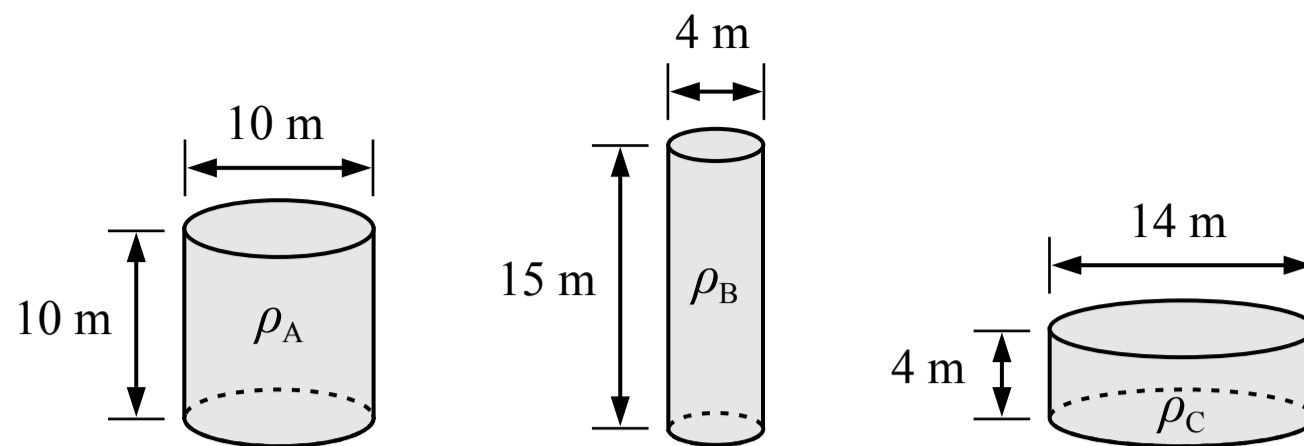

33. The heights and diameters of three cylinders are shown in the figure above. All three cylinders are filled with the same mass of gas. Which of the following correctly relates the densities of the gas in each cylinder?

- (A)  $\rho_C < \rho_A < \rho_B$
- (B)  $\rho_B < \rho_C < \rho_A$
- (C)  $\rho_A < \rho_C < \rho_B$
- (D)  $\rho_A = \rho_B = \rho_C$

**A** Incorrect

This answer may have been found by incorrectly ranking the volumes of the cylinders based on height only.

**B** Incorrect

This answer may have been found by incorrectly reversing the order of the density ranking.

**C** Correct

We can find the density of the gas in each cylinder in terms of the same mass  $m$  and compare the densities.

$$\rho_A = \frac{m}{V_A} = \frac{m}{\pi r^2 h} = \frac{m}{\pi(5 \text{ m})^2(10 \text{ m})} = \frac{m}{785 \text{ m}^3}$$

$$\rho_B = \frac{m}{V_B} = \frac{m}{\pi r^2 h} = \frac{m}{\pi(2 \text{ m})^2(15 \text{ m})} = \frac{m}{188 \text{ m}^3}$$

$$\rho_C = \frac{m}{V_C} = \frac{m}{\pi r^2 h} = \frac{m}{\pi(7 \text{ m})^2(4 \text{ m})} = \frac{m}{616 \text{ m}^3}$$

$$\rho_A < \rho_C < \rho_B$$

**D** Incorrect

This answer may have been found by incorrectly assuming the density of the gas in each cylinder is the same.

Related course pages: [8 - Fluids & Density](#)

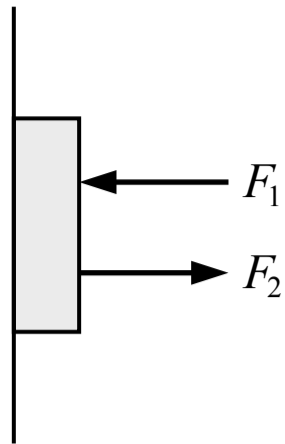

34. A book is at rest against a wall with two forces acting on it as shown in the figure above. Which of the following represent the magnitude of the force acting on the book by the wall?

- (A)  $F_2 - F_1$
- (B)  $F_1 + F_2$
- (C)  $F_1 - F_2$
- (D)  $-F_1 - F_2$

(A) Incorrect

This answer incorrectly assumes the normal force on the book is acting to the left instead of the right:

$$F_2 - F_1 - F_n = m(0)$$

(B) Incorrect

This answer incorrectly adds the forces in the following way:

$$F_1 + F_2 - F_n = m(0)$$

(C) **Correct**

Newton's 1st law can be applied to the book to find the normal force acting on the book by the wall in terms of the other forces:

$$\sum F_x = m a_x \quad F_2 - F_1 + F_n = m(0) \quad F_n = F_1 - F_2$$

(D) Incorrect

This answer incorrectly adds the forces in the following way:

$$F_1 + F_2 + F_n = m(0)$$

Related course pages: [2 - Newton's 1st Law & Forces](#), [2 - Newton's 3rd Law & Normal Force](#)

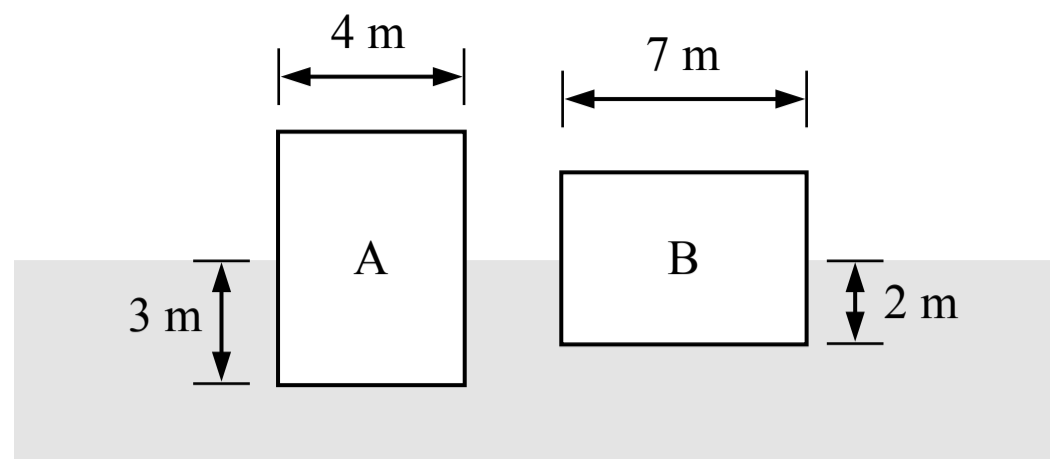

Note: Figure not drawn to scale.

35. Two solid blocks are floating at rest in a liquid as shown in the figure above. The blocks have the same thickness (the dimension into/out of the page). Which of the two blocks has a greater mass?

- (A) Block A
- (B) Block B
- (C) They have the same mass
- (D) Cannot be determined

(A) Incorrect

**(B) Correct**

Each block is at rest so the net force on the block is zero (Newton's 1st law), and the upwards buoyant force on a block is equal to the downwards weight force on the block. We can simplify that equation to get an expression for the mass of each block in terms of the width, depth below the surface, thickness  $t$  and fluid density  $\rho_f$  and then compare the masses. Block B displaces more fluid volume so it has a greater mass.

$$\text{Block A: } \sum F_y = F_B - F_g = 0 \quad F_g = F_B \quad mg = \rho_f V_f g \quad m = \rho_f V_f = \rho_f (4 \text{ m})(3 \text{ m})t = (12 \text{ m}^2)\rho_f t$$

$$\text{Block B: } \sum F_y = F_B - F_g = 0 \quad F_g = F_B \quad mg = \rho_f V_f g \quad m = \rho_f V_f = \rho_f (7 \text{ m})(2 \text{ m})t = (14 \text{ m}^2)\rho_f t$$

(C) Incorrect

(D) Incorrect

Related course pages: 2 - Newton's 1st Law & Forces, 8 - Buoyant Force

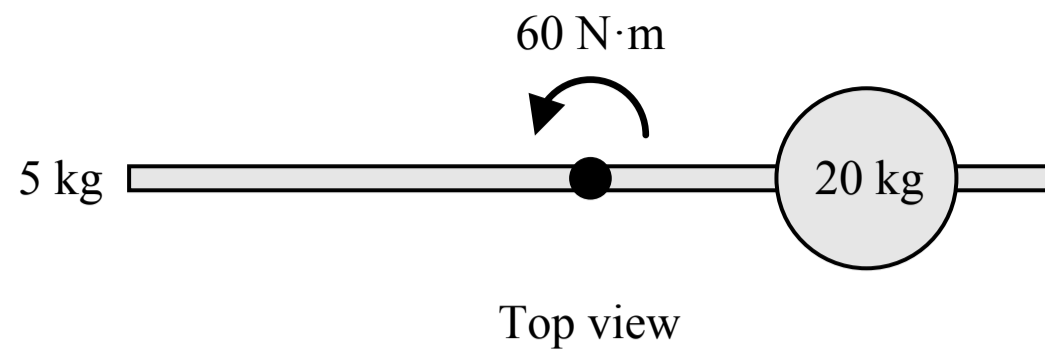

36. A 20 kg sphere is attached to a 5 kg rod which is free to rotate about its center as shown in the figure above. A 60 N·m torque is applied to the rod by a force which is not shown, and the rod and sphere rotate with an angular acceleration. Which of the following changes would increase the angular acceleration of the rod and sphere?

- (A) Decrease the mass of the rod
- (B) Move the sphere farther from the center of the rod
- (C) Increase the mass of the sphere
- (D) Increase the total length of the rod so the total mass of the rod remains the same and it rotates about its center

**A Correct**

The net torque acting on the system is equal to the rotational inertia of the system multiplied by the angular acceleration:  $\sum \tau = I\alpha$ . Decreasing the rotational inertia would increase the angular acceleration. The rotational inertia of the system depends on the distribution of mass relative to the point of rotation. Decreasing the mass of the rod would decrease the rotational inertia and increase the angular acceleration.

**B Incorrect**

Moving the sphere farther from the center of the rod would increase the system's rotational inertia and decrease the angular acceleration.

**C Incorrect**

Increasing the mass of the sphere would increase the system's rotational inertia and decrease the angular acceleration.

**D Incorrect**

Increasing the length of the rod would move mass away from the point of rotation which would increase the system's rotational inertia and decrease the angular acceleration.

Related course pages: [5 - Rotational Dynamics](#)

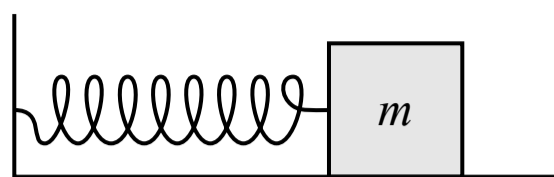

Spring Length  
(cm)

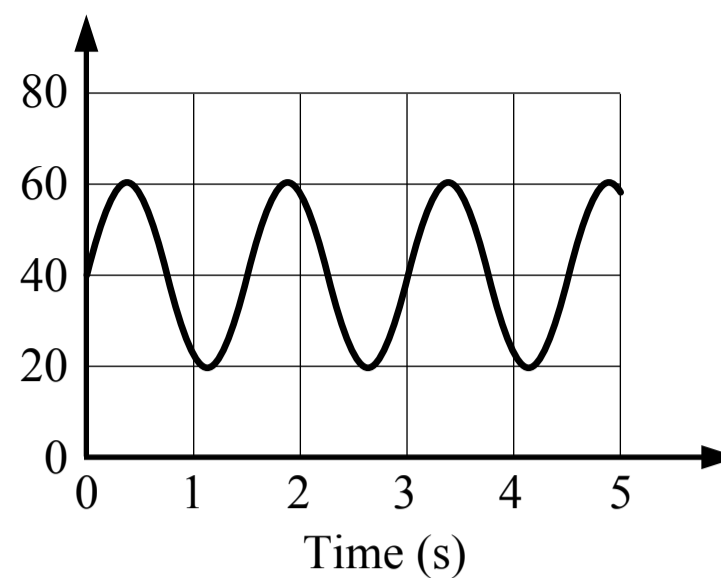

37. A block is attached to a spring with a spring constant of 50 N/m as shown in the figure above. The block is oscillating back and forth on a surface with negligible friction and the length of the spring over time is shown in the graph above. The mass of the block is most nearly

- (A) 112.5 kg
- (B) 11.4 kg
- (C) 2.8 kg
- (D) 0.7 kg

(A) Incorrect

This answer excludes the  $2\pi$  in the equation for the period of the oscillation.

(B) Incorrect

This answer incorrectly uses 3 seconds for the period of the oscillation.

(C) Correct

The period of the mass-spring oscillation depends on the mass and the spring constant. The period of the oscillation is 1.5 seconds which can be found from the graph (there is 1.5 seconds per cycle or 3 seconds for 2 cycles).

$$T_{sp} = 2\pi\sqrt{\frac{m}{k}} \quad 1.5 \text{ s} = 2\pi\sqrt{\frac{m}{50 \text{ N/m}}} \quad m = 2.8 \text{ kg}$$

(D) Incorrect

This answer incorrectly uses 0.75 seconds for the period of the oscillation.

Related course pages: 7 - Simple Harmonic Motion

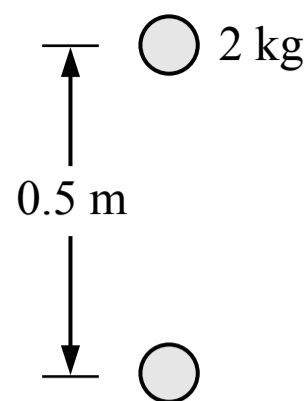

38. A person is holding a ball with a mass of 2 kg in the air at rest. They lower the ball a distance of 0.5 m at a constant speed and bring it to rest again at the lower height. Which of the following is true about the ball system between the initial and final heights?

- (A) The person does positive work on the system
- (B) The total energy of the system does not change
- (C) Gravity does zero work on the system
- (D) The total energy of the system decreases

(A) Incorrect

**(B) Correct**

The system is defined as only the ball and does not include the earth so the system can only have kinetic energy and it cannot have gravitational potential energy. The force from the person does negative work on the ball system (because the force from the person and the displacement are in opposite directions) and gravity does positive work on the ball system. The total amount of work done is zero and the change in kinetic energy is zero (the ball starts and ends at rest).

(C) Incorrect

(D) Incorrect

Related course pages: [3 - Conservation of Energy, Work & Power](#)

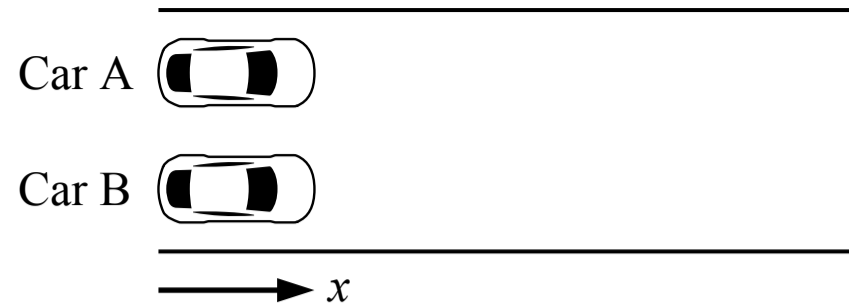

39. Two cars are stopped next to each other on a straight road as shown in the figure above. At the same starting time, car A drives forward with a constant speed of 10 m/s and car B accelerates forward at 2 m/s<sup>2</sup>. How far apart are the two cars (in the  $x$  direction) after 5 seconds?

- (A) 115 m
- (B) 25 m
- (C) 40 m
- (D) 100 m

(A) Incorrect

This answer incorrectly switches the value of car A's speed and car B's acceleration.

(B) **Correct**

The final positions of the cars can be found using the kinematic equation below.

$$\text{Car A: } x = x_0 + v\Delta t = (0 \text{ m}) + (10 \text{ m/s})(5 \text{ s}) = 50 \text{ m}$$

$$\text{Car B: } x = x_0 + v_0 t + \frac{1}{2} a t^2 = (0 \text{ m}) + (0 \text{ m/s})(5 \text{ s}) + \frac{1}{2} (2 \text{ m/s}^2)(5 \text{ s})^2 = 25 \text{ m}$$

$$\text{Distance between the cars: } (50 \text{ m}) - (25 \text{ m}) = 25 \text{ m}$$

(C) Incorrect

This answer incorrectly uses the value of car B's acceleration as a constant speed of 2 m/s.

(D) Incorrect

This answer incorrectly uses the value of car A's constant speed as an acceleration of 10 m/s<sup>2</sup>.

Related course pages: [1 - 1D Motion](#)

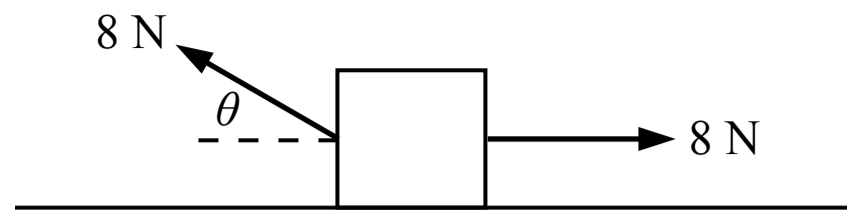

40. A block is sitting at rest on a surface with negligible friction when two forces are applied to the block as shown in the figure above. If the block remains in contact with the surface, which of the following graphs shows the motion of the block starting when the forces are applied?

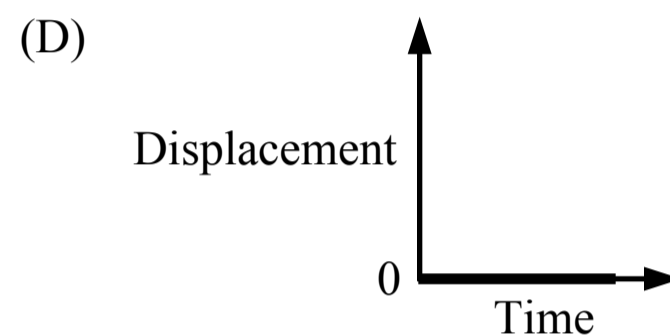
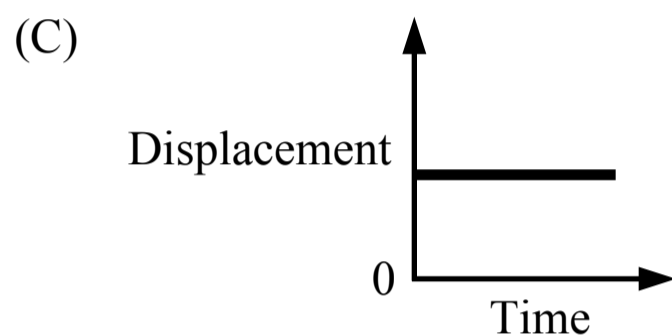
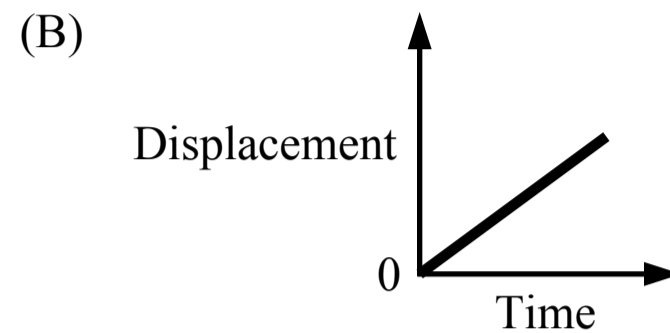
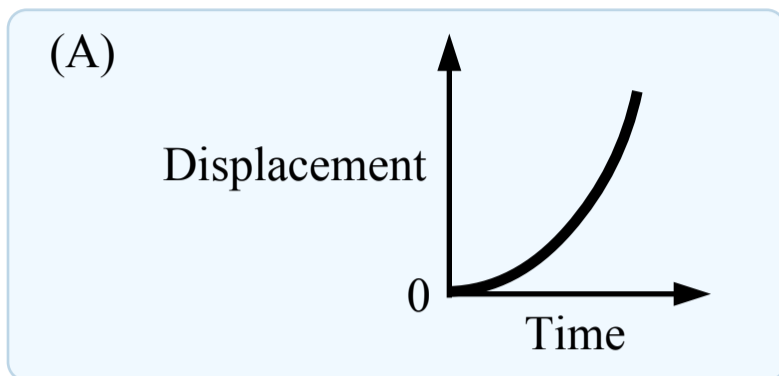

**A Correct**

The block remains in contact with the surface (it does not accelerate in the vertical direction) so the net force in the vertical direction is zero (Newton's 1st law). The net force in the horizontal direction is the 8 N force to the right minus the horizontal component of the 8 N force to the left. The left force acts at an angle so the horizontal component (the leftwards force) must be less than 8 N, so there is a net horizontal force to the right. If a net force acts on an object, the object will accelerate (Newton's 1st law) and the position-time graph or the displacement-time graph is a curved line (the slope is changing because the velocity is changing).

$$\Sigma F_x = m a_x \quad (8 \text{ N}) - (8 \text{ N}) \cos(\theta) = m a_x$$

**B Incorrect**

This graph would be correct if the net force on the block was zero and the block started with an initial speed.

**C Incorrect**

**D Incorrect**

This graph would be correct if the net force on the block was zero.

Related course pages: 1 - 1D Motion, 2 - Newton's 1st Law & Forces